



**STEINBOCK GmbH**

Industrie-Ausrüstungen • Industrial Components

# VulcaFlex

## Vulkanisierte Faltenbälge

## Moulded Bellows

**VF 03**



## Einen Moment bitte ...

für ein paar nützliche Informationen.

1. Die Faltenbälge in diesem Katalog sind normalerweise sofort **ab Lager** lieferbar.
2. Die Buchstaben in der Artikelnummer weisen auf das Material hin, in dem die Faltenbälge standardmäßig lieferbar sind. **Ab 10 Stück fertigen wir auch in anderen Materialien (CR, Si, EPDM)**. Eine **Materialliste** finden Sie im Katalog.
3. Wenn Sie „Ihren“ Faltenbalg im Katalog nicht finden - kein Problem: wir fertigen nach Ihren Wünschen. Egal, welche Menge. **Anfrageformulare** finden Sie interaktiv auf unserer Website [www.steinbock-industrie.de](http://www.steinbock-industrie.de).
4. In der ersten Liste sind die Faltenbälge nach dem **kleinsten Anschlussdurchmesser** geordnet.
5. In der zweiten Liste sind alle Faltenbälge nach der **Artikelnummer** (Art.No.) sortiert.
6. Anschließend finden Sie die **Zeichnungen** der Faltenbälge nach dem kleinsten Anschlussdurchmesser geordnet.
7. Selbstverständlich liefern wir Ihnen auf Wunsch auch die passenden **Schlauchschellen**.

## *Just a moment please...*

*for some useful bits of information.*

1. *The bellows described in this catalog are normally available **from stock**.*
2. *The letters in our article numbers specify the material in which the bellows are normally available. **For orders of 10 units and more, these bellows can also be supplied in other materials (CR, Si, EPDM)**. For a **list of materials** you will find in this catalog.*
3. *Should you be unable to find the bellows you need - no problem. We will make it to your specifications, regardless of quantity. For **inquiry forms** visit our website [www.steinbock-industrie.de](http://www.steinbock-industrie.de).*
4. *In the first list the bellows are classified by **smallest fitting diameter**.*
4. *In the next list all bellows are sorted according to **article numbers** (Art.No.).*
6. *Then you will find **drawings** of the bellows, sorted according to smallest fitting diameter.*
7. *We will, of course, supply suitable **hose clamps** as well.*



## Typische Eigenschaften von Elastomeren

Wir sind so flexibel wie unsere Faltenbälge. Die meisten, in diesem Katalog aufgeführten Bälge sind standardmäßig aus Nitrilgummi (NBR). Bereits ab 10 Stück liefern wir diese auch aus CR, Si oder EPDM.

	Nitrilkautschuk	Chloropren- kautschuk	Ethylen- Polypropylen-Dien- kautschuk	Silikonkautschuk
Internationales Kurzzeichen	<b>NBR</b>	<b>CR</b>	<b>EPDM</b>	<b>Si</b>
Handelsnamen (Beispiele)	Perbunan	Chloroprene Neoprene	Buna EP Keltan	Silicone Silastic
<b>Mechanische Eigenschaften bei Raumtemperatur</b>				
Reißfestigkeit	2	2	3	3
Reißdehnung	2	2	3	2
Rückparallelelastizität	3	3	2	2
Weiterreißwiderstand	3	2	3	3
Abriebwiderstand	1	3	3	4
Widerstand gegen bleibende Verformung	bei hohen Temperaturen	3	2	1
	bei niedrigen Temperaturen	3	3	1
<b>Thermisches Verhalten</b>				
Kälteflexibel bis °C	- 30	- 35	- 50	- 65
Dauereinsatztemperatur max. in °C	+100	+100**	+130*	+200
<b>Beständigkeit</b>				
Benzin	2	4	5	4
Mineralöl (bei 100°C)	1	3	5	3
Säuren (25%ige Schwefelsäure bei 50°C)	3	2	1	3
Laugen (50%ige Natronlauge bei 50°C)	4	2	1	5
Wasser (bei 100°C)	3	3	1	2
Witterung und Ozon	4	1	1	1
Luftundurchlässigkeit	2	3	3	5
Alterung	2	2	1	1

1 = sehr gut 2 = gut 3 = befriedigend 4 = unbefriedigend 5 = nicht geeignet

\* = Spezialmischung bis +220°C      \*\* = Spezialmischung bis 190°C

Die angegebenen Werte sind nur richtungsweisend und entbinden den Kunden nicht von der Verantwortung eigene Versuche zur Evaluierung der Einsatzfähigkeit durchzuführen.

Alle Angaben sind nach unserem Wissen korrekt. Wir übernehmen keine Gewährleistung auf die Richtigkeit und Vollständigkeit der Angaben.



## Typical Characteristics of Elastomers

We are just as flexible as our bellows. Most of the bellows described in this catalog are normally made of nitrile rubber (NBR).

However, starting with orders for as few as 10 units we will also make these bellows of CR, Si oder EPDM.

	Nitril Rubber	Chloroprene Rubber	Ethylene Polypropylene Diene Rubber	Silicone Rubber
International abbreviation	<b>NBR</b>	<b>CR</b>	<b>EPDM</b>	<b>Si</b>
Trade name (e.g.)	Perbunan	Chloroprene Neoprene	Buna EP Keltan	Silicone
<b>Mechanical characteristics at room temperature</b>				
Tensile strength	2	2	3	3
Elongation at break	2	2	3	2
Rebound resilience	3	3	2	2
Tear strength / tear resistance	3	2	3	3
Abrasion resistance	1	3	3	4
Compression set after constant strain	at high temperatures	3	2	1
	at low temperatures	3	3	1
<b>Thermal properties</b>				
Low-temperature flexibility down to °C	- 30	- 35	- 50	- 65
Max. service temperature in °C	+100	+100**	+130*	+200
<b>Resistance against:</b>				
Gasoline	2	4	5	4
Mineral oil (at 100°C)	1	3	5	3
Acids (25% sulphuric acid at 50°C)	3	2	1	3
Lyes (50%ige caustic soda at 50°C)	4	2	1	5
Water (at 100°C)	3	3	1	2
Weathering and ozone	4	1	1	1
Air impermeability	2	3	3	5
Ageing	2	2	1	1

1 = very good 2 = good 3 = satisfactory 4 = not satisfactory 5 = insufficient

\* = Special compounds up to +220°C \*\* = Special compounds up to 190°C

This table can only act as a rough guideline for the characteristics of the various types Elastomers.



# Vulkanisierte Faltenbälge/Moulded Bellows

# Art. No.

<b>Art. No.</b>	<b>Kleinster Anschluss-Ø</b> Smallest inside fitting diameter Plus petit Ø intérieur de fixation Ø interior mínimo	<b>Größter Anschluss-Ø</b> Largest inside fitting diameter Le plus grand Ø intérieur de fixation Ø interior máximo	<b>Produktionslänge</b> Production length Longueur de production Longitud de suministro	<b>Lmin</b>  Length min  Longueur min  Longitud min.	<b>Lmax</b>  Length max  Longueur max  Longitud máx.	<b>Seite</b>  Page  Pagina
F 1001 NBR	24	24	93	27	55	19
F 1002 NBR	41	41	118	0	46	36
F 1003 NBR	22	22	58	0	10	17
F 1004 NBR	27	27	104	0	24	21
F 1005 NBR	41	41	162	0	0	36
F 1006 NBR	22	27	102	32	110	18
F 1008 NBR	26	34	90	35	100	21
F 1010 NBR	12	16	30	8	30	8
F 1011 NBR	4	11	45	9	18	1
F 1012 NBR	22	30	180	65	180	18
F 1013 NBR	21	32	125	45	120	17
F 1014 NBR	39	39	200	80	240	34
F 1016 NBR	52	52	195	75	230	44
F 1017 NBR	23	95	190	60	250	19
F 1018 NBR	21	30	115	36	120	17
F 1020 NBR	35	43	180	52	220	29
F 1021 NBR	58	61	130	25	180	46
F 1022 NBR	7	17	32	10	23	3
F 1023 NBR	7	17	52	25	32	3
F 1025 NBR	48	66	66	15	65	40
F 1026 NBR	37	56	75	25	130	31
F 1027 NBR	60	60	130	30	170	47
F 1028 NBR	28	47	64	14	55	22
F 1029 NBR	22	47	67	18	56	18
F 1030 NBR	48	84	100	42	90	40
F 1031 NBR	60	70	300	80	385	47
F 1032 NBR	9	24	25	0	7	5
F 1033 NBR	20	64	35	9	40	16
F 1035 NBR	4,5	7,5	16	3,5	8,5	1
F 1036 NBR	37	40	125	43	160	31
F 1037 NBR	11	11	21	10	12	7
F 1038 NBR	18	54	125	36	135	14
F 1039 NBR	12	56	70	25	60	8
F 1040 NBR	40	40	115	28	205	34
F 1041 NBR	6	17	57	27	50	3
F 1042 NBR	5	25	47,5	13	28	2
F 1043 NBR	27	42	80	15	70	22
F 1044 NBR	10	10	36	18	45	6
F 1045 NBR	4	11	70	20	55	1
F 1046 NBR	140	140	98	19	120	62
F 1047 NBR	5	16	57,5	26	57	2
F 1048 NBR+Si	10	20	33,5	23	45	6
F 1049 NBR	72	90	120	0	0	53
F 1050 NBR	12	70	121	32	150	8



# Vulkanisierte Faltenbälge/Moulded Bellows

# Art. No.

<b>Art. No.</b>	<b>Kleinster Anschluss-Ø</b> Smallest inside fitting diameter Plus petit Ø intérieur de fixation Ø interior mínimo	<b>Größter Anschluss-Ø</b> Largest inside fitting diameter Le plus grand Ø intérieur de fixation Ø interior máximo	<b>Produktionslänge</b> Production length Longueur de production Longitud de suministro	<b>Lmin</b>  Length min  Longueur min  Longitud min.	<b>Lmax</b>  Length max  Longueur max  Longitud máx.	<b>Seite</b>  Page  Pagina
F 1051 NBR	16	28	116	48	120	12
F 1052 NBR	16	21	88	30	120	11
F 1053 NBR	21	32	40	17	30	16
F 1054 NBR	20	28	94	30	140	15
F 1055 NBR	50	63	116	50	240	42
F 1057 NBR	32	36	194	43	180	26
F 1058 NBR	32	38	183	40	210	27
F 1059 NBR	27	27	155	38	220	21
F 1060 NBR	15	62	82	25	80	11
F 1061 NBR	72	75	50	13	80	52
F 1062 NBR	29	73	134	27	150	23
F 1063 NBR	17	17	99	25	100	12
F 1064 NBR	40	45	90	20	130	35
F 1066 NBR	160	186	220	45	310	64
F 1067 NBR	210	210	200	45	350	64
F 1068 NBR	114	116	170	43	250	61
F 1069 NBR	260	280	265	80	600	65
F 1070 NBR	95	95	100	38	190	58
F 1071 NBR	90	90	88	31	190	57
F 1072 NBR	34	34	130	38	165	28
F 1073 NBR	30	30	145	43	190	24
F 1074 NBR	100	100	105	33	200	59
F 1075 NBR	33	45	140	35	240	28
F 1076 NBR	54	54	210	70	400	44
F 1077 NBR	150	180	140	32	200	63
F 1078 NBR	44	55	110	22	125	37
F 1079 NBR	155	165	180	75	340	63
F 1080 NBR	12	36	39	22	40	8
F 1082 NBR	145	150	115	32	140	63
F 1083 NBR	43	54	103	20	140	37
F 1084 NBR+Si	7	12,5	26	10	30	3
F 1085 NBR	110	155	67	14	90	60
F 1087 NR	35	35	140	37	240	28
F 1088 NBR	67	75	80	23	150	50
F 1089 NBR	92	118	90	31	200	57
F 1090 NBR+Si	90	90	80	12	95	57
F 1091 NBR	70	70	80	40	40	50
F 1092 NBR	3	7	23,5	7	22,5	1
F 1095 NBR	29	72	150	25	200	23
F 1096 NBR	73	73	36	7	45	52
F 1098 NBR	5	7	40	20	32	2
F 1099 NBR	32	54	36	8	70	27
F 1100 NBR	4,5	19	28	12	28	2
F 1101 NBR	6,5	28	44	15	35	3





# Vulkanisierte Faltenbälge/Moulded Bellows

# Art. No.

<b>Art. No.</b>	<b>Kleinster Anschluss-Ø</b> Smallest inside fitting diameter Plus petit Ø intérieur de fixation Ø interior mínimo	<b>Größter Anschluss-Ø</b> Largest inside fitting diameter Le plus grand Ø intérieur de fixation Ø interior máximo	<b>Produktionslänge</b> Production length Longueur de production Longitud de suministro	<b>Lmin</b>  Length min  Longueur min  Longitud min.	<b>Lmax</b>  Length max  Longueur max  Longitud máx.	<b>Seite</b>  Page  Pagina
F 1102 NBR	8	36	45	25	50	4
F 1103 NBR	30	45	120	34	210	25
F 1104 NBR	13	33	54	12	43	9
F 1105 CR	40	55	210	70	440	36
F 1107 NBR	26	52	102	30	150	21
F 1109 NBR	74	74	105	29	180	53
F 1110 NR	140	176	105	17	120	62
F 1111 NBR	98	98	100	18	140	58
F 1112 NBR	50	50	172	68	185	42
F 1113 NBR	98	98	80	12	85	58
F 1114 NBR	30	30	165	77	260	24
F 1115 NBR	32	47	210	74	280	27
F 1117 NBR	4	18	32	12	27	1
F 1118 NBR	85	85	60	13	120	57
F 1119 NBR	32	32	83	28	95	26
F 1122 NBR	180	220	75	11	110	64
F 1123 NBR	48	48	280	140	450	40
F 1125 NBR	45	45	45	10	25	37
F 1126 NBR	49	49	320	140	510	41
F 1127 NBR	30	30	170	47	280	24
F 1128 NBR	30	30	135	25	160	23
F 1129 NBR	6	17	48	25	50	3
F 1130 NBR	9	16	58	30	60	5
F 1132 NBR	47	65	112	24	160	39
F 1133 NBR	8	20	58	25	56	4
F 1134 NBR	20	41	83	14	60	16
F 1135 NBR	40	40	170	33	205	35
F 1137 NBR	45	45	97	30	75	37
F 1138 NBR	4	10	60	12	50	1
F 1139 NBR	16	22	148	48	150	12
F 1141 NBR	50	50	210	40	300	42
F 1143 NBR	8	27	49	15	39	4
F 1144 NBR	18	44	44	6	25	14
F 1146 NBR	28	70	56	5	45	22
F 1147 NBR	60	130	170	40	240	48
F 1148 NBR	70	70	100	20	160	50
F 1149 NBR	20	20	100	25	130	15
F 1149 Si	20	20	100	25	130	15
F 1150 NBR	20	32	215	65	250	16
F 1151 NBR	29	29	55	10	55	22
F 1152 NBR	29	32	60	20	60	22
F 1153 NBR	25	50	36	18	37	20a
F 1154 NBR	23	50	35	0	31	18
F 1155 NBR	14	25	93	30	120	10



# Vulkanisierte Faltenbälge/Moulded Bellows

# Art. No.

<b>Art. No.</b>	<b>Kleinster Anschluss-Ø</b> Smallest inside fitting diameter Plus petit Ø intérieur de fixation Ø interior mínimo	<b>Größter Anschluss-Ø</b> Largest inside fitting diameter Le plus grand Ø intérieur de fixation Ø interior máximo	<b>Produktionslänge</b> Production length Longueur de production Longitud de suministro	<b>Lmin</b>  Length min  Longueur min  Longitud min.	<b>Lmax</b>  Length max  Longueur max  Longitud máx.	<b>Seite</b>  Page  Pagina
F 1157 NBR	40	48	115	27	180	36
F 1158 NBR	35	49	108	16	90	29
F 1159 NBR	64	84	95	20	150	49
F 1160 NBR	49	75	85	10	60	41
F 1162 NBR	11	25	88	25	75	7
F 1164 NBR	80	80	230	70	240	55
F 1169 NBR	71	71	38	4	14	51
F 1170 NBR	130	130	210	55	360	62
F 1171 NBR	20	42,5	33	0	20	15
F 1172 NBR	120	120	230	57	400	61
F 1173 NBR	49	49	102	30	55	41
F 1175 NBR	22	32	128	50	150	18
F 1176 NBR	38	69	135	39	210	32
F 1177 NBR	17	23	59	15	60	12
F 1179 NBR	75	75	210	75	340	54
F 1180 NBR	16	40	105	25	85	12
F 1181 NBR	137	137	310	80	550	62
F 1182 NBR	56	56	130	45	145	46
F 1185 NBR	9,5	9,5	36	7	20	6
F 1186 NBR	70	70	290	74	420	51
F 1187 NBR	5	10	50	12	45	2
F 1188 NBR	46	60	160	60	220	40
F 1189 NBR	18	71	86	20	95	14
F 1190 NBR	25	25	20	4	23	20
F 1191 NBR	52	52	78	15	85	45
F 1192 NBR	25	25	68	9	65	20
F 1193 NBR	10	10	86	37	50	6
F 1197 NBR	80	80	230	50	330	55
F 1201 CR	85	85	285	55	460	56
F 1201 NBR	85	85	285	55	460	56
F 1202 NBR	45	45	123	33	145	37
F 1203 NBR	130	130	100	15	140	61
F 1204 NBR	127	127	185	40	220	61
F 1205 NBR	50	50	125	40	160	41
F 1206 NBR	33	35	200	55	300	27
F 1207 NBR	60	60	205	52	260	47
F 1208 NBR + Si	50	56	155	45	180	42
F 1209 NBR	35	35	164	47	210	28
F 1210 NBR	30	30	145	40	210	24
F 1211 NBR	70	70	205	52	260	51
F 1212 NBR	20	100	100	18	100	16
F 1214 NBR	38	38	46	13	60	32
F 1215 NBR	25	25	98	28	120	20
F 1216 NBR	110	110	225	60	280	60





# Vulkanisierte Faltenbälge/Moulded Bellows

# Art. No.

<b>Art. No.</b>	<b>Kleinster Anschluss-Ø</b> Smallest inside fitting diameter Plus petit Ø intérieur de fixation Ø interior mínimo	<b>Größter Anschluss-Ø</b> Largest inside fitting diameter Le plus grand Ø intérieur de fixation Ø interior máximo	<b>Produktionslänge</b> Production length Longueur de production Longitud de suministro	<b>Lmin</b>  Length min  Longueur min  Longitud min.	<b>Lmax</b>  Length max  Longueur max  Longitud máx.	<b>Seite</b>  Page  Pagina
F 1217 NBR	90	90	210	50	320	57
F 1218 NBR	100	100	200	40	250	59
F 1221 NBR	85	85	210	40	260	56
F 1222 NBR	65	65	200	40	300	49
F 1223 NBR	45	45	180	40	230	38
F 1224 NBR	80	80	210	50	250	55
F 1225 NBR	81	81	85	15	100	56
F 1229 NBR	45	45	210	55	270	38
F 1230 NBR	24,5	24,5	155	45	190	19
F 1231 NBR	39	52	137	40	150	33
F 1232 NBR	29	70	78	15	75	23
F 1233 NBR	40	40	200	55	280	35
F 1234 NBR	36	41	180	55	165	30
F 1235 NBR	15	15	95	25	90	11
F 1236 NBR	10	10	90	20	95	6
F 1237 NBR	95	95	220	60	310	58
F 1238 NBR	30	30	210	75	280	25
F 1239 NBR	64	82	125	35	130	49
F 1240 NBR	150	150	280	80	470	63
F 1241 NBR	17	37	140	25	170	13
F 1242 NBR	20	20	155	50	180	15
F 1244 NBR	62	62	150	56	200	49
F 1245 NBR	51	51	210	60	280	43
F 1246 NBR	45	60	210	50	240	39
F 1248 NBR	55	55	210	70	280	45
F 1249 NBR	35	35	230	84	354	29
F 1250 NBR	25	40	155	40	190	20
F 1251 NBR	10	10	40	20	50	5a
F 1252 NBR	53,5	90	235	110	300	45
F 1516 NBR	30	54	155	56	162	26
F 1521 NBR	36	39	340	120	560	31
F 1522 NBR	45	70	192	72	500	39
F 1528 NBR	70	84	168	52	250	51
F 2001 NBR+Si	60	60	235	45	300	48
F 2104 NBR	7	12,5	26	10	30	4
F 2006 NBR	55	55	65	0	0	45
F 2015 NBR	52	52	115	35	120	44
F 2067 NBR	74	74	75	18	100	53
F 2075 NBR	75	75	245	50	345	54
F 2107 CR	10	56	160	50	140	5a
F 2231 CR	7	20	120	46	127	4
F 3010 NBR	39	53	145	55	150	33
F 3012 NBR	39	45	165	0	0	33
F 3037 NBR	9	44	145	137	137	5



# Vulkanisierte Faltenbälge/Moulded Bellows

# Art. No.

<b>Art. No.</b>	<b>Kleinster Anschluss-Ø</b> Smallest inside fitting diameter Plus petit Ø intérieur de fixation Ø interior mínimo	<b>Größter Anschluss-Ø</b> Largest inside fitting diameter Le plus grand Ø intérieur de fixation Ø interior máximo	<b>Produktionslänge</b> Production length Longueur de production Longitud de suministro	<b>Lmin</b>  Length min  Longueur min  Longitud min.	<b>Lmax</b>  Length max  Longueur max  Longitud máx.	<b>Seite</b>  Page  Pagina
F 3038 NBR	9	35	155	140	140	5
F 4001 NBR	80	85	160	50	130	55
F 4002 NBR	79	110	130	35	120	54
F 4003 NBR	70	70	300	120	500	52
F 4004 NBR	70	88	260	90	320	52
F 4005 NBR	67	67	90	20	40	50
F 4008 NBR	60	60	146	45	220	48
F 4009 NBR	59	151	150	60	160	46
F 4010 NBR	56	86	260	90	320	46
F 4011 NBR	55	70	250	90	300	45
F 4012 NBR	50	50	330	100	635	43
F 4013 NBR	46	65	250	80	350	39
F 4014 NBR	40	52	40	15		34
F 4015 NBR	38	38	80	30	70	32
F 4016 NBR	38	41	88	30	77	33
F 4017 NBR	36	36	111	30	86	31
F 4018 NBR	35	70	180	55	200	29
F 4019 NBR	35	70	250	70	330	30
F 4020 NBR	30	30	75	20		25
F 4022 NBR	23	65	120	40	130	19
F 4023 NBR	20	20	78	24	60	15
F 4024 NBR	18	29	50	10	28	13
F 4027 NBR	11	20	50	15	43	7
F 4029 NBR	10,5	22	80	20	90	6
F 4031 NBR	5,5	20	25	10	0	2
F 4037 NBR	50	94	80	50	180	43
F 4038 NBR	45	45	82	35	58	38
F 4039 NBR	40	71	380	120	520	35
F 4040 NBR	35	113/106	100	35	90	30
F 4041 NBR	25	25	145	80	200	20a
F 4043 NBR	22	36	98	30	76	17
F 4047 NBR	19	40	48	10	31	14
F 4048 NBR	18	40	62	20	35	13
F 4049 NBR	17	40	62	20	41	13
F 4051 NBR	11	43	125	55	150	7
F 4054 NBR	12	42	100	42	110	9
F 4056 NBR	105	105	130	30	110	60
F 4057 NBR	75	75	134	40	140	53
F 4058 NBR	14	27	184	55	230	10
F 4059 NBR	100	100	353	90	350	59
F 4060 NBR	110	110	131	50	125	60
F 4061 NBR	40	48	544	180	560	34
F 4063 NBR	12	24	120	40	110	9
F 4064 NBR	65	86	190	50	200	50



# Vulkanisierte Faltenbälge/Moulded Bellows

# Art. No.

<b>Art. No.</b>	<b>Kleinster Anschluss-Ø</b> Smallest inside fitting diameter Plus petit Ø intérieur de fixation Ø interior mínimo	<b>Größter Anschluss-Ø</b> Largest inside fitting diameter Le plus grand Ø intérieur de fixation Ø interior máximo	<b>Produktionslänge</b> Production length Longuer de production Longitud de suministro	<b>Lmin</b>  Length min  Longueur min  Longitud min.	<b>Lmax</b>  Length max  Longueur max  Longitud máx.	<b>Seite</b>  Page  Pagina
F 4065 NBR	14	14	155	35	140	10
F 4066 NBR	38	38	120	28	130	32
F 4067 NBR	30	38	70	23	60	25
F 4068 NBR	25	38	50	18	50	20
F 4069 NBR	45	45	145	45	175	38
F 9000 NBR	100	140	150	28	200	58
F 9001 Si	28	32		15	45	22
F 9002 NBR	62	62	70	15	80	48
F 9003 NBR	45	65,5	30	5	15	38
F 9004 NBR	60	86	39,5	5	15	47
F 9008 NBR	16	62	40	10	25	11
F 9009 NBR	28	82		35	120	21
F 9010 NBR	50	155	120	20	100	43
F 9011 NBR	10	25	30	12	35	5



# Vulkanisierte Faltenbälge/Moulded Bellows

Ø/Dia.

<b>Art. No.</b>	<b>Kleinster Anschluss-Ø</b> Smallest inside fitting diameter Plus petit Ø intérieur de fixation Ø interior mínimo	<b>Größter Anschluss-Ø</b> Largest inside fitting diameter Le plus grand Ø intérieur de fixation Ø interior máximo	<b>Produktionslänge</b> Production length Longueur de production Longitud de suministro	<b>Lmin</b>  Length min  Longueur min  Longitud min.	<b>Lmax</b>  Length max  Longueur max  Longitud máx.	<b>Seite</b>  Page  Pagina
F 1092 NBR	3	7	23,5	7	22,5	1
F 1011 NBR	4	11	45	9	18	1
F 1045 NBR	4	11	70	20	55	1
F 1117 NBR	4	18	32	12	27	1
F 1138 NBR	4	10	60	12	50	1
F 1035 NBR	4,5	7,5	16	3,5	8,5	1
F 1100 NBR	4,5	19	28	12	28	2
F 1042 NBR	5	25	47,5	13	28	2
F 1047 NBR	5	16	57,5	26	57	2
F 1098 NBR	5	7	40	20	32	2
F 1187 NBR	5	10	50	12	45	2
F 4031 NBR	5,5	20	25	10	0	2
F 1041 NBR	6	17	57	27	50	3
F 1129 NBR	6	17	48	25	50	3
F 1101 NBR	6,5	28	44	15	35	3
F 1022 NBR	7	17	32	10	23	3
F 1023 NBR	7	17	52	25	32	3
F 1084 NBR+Si	7	12,5	26	10	30	3
F 2104 NBR	7	12,5	26	10	30	4
F 2231 CR	7	20	120	46	127	4
F 1102 NBR	8	36	45	25	50	4
F 1133 NBR	8	20	58	25	56	4
F 1143 NBR	8	27	49	15	39	4
F 1032 NBR	9	24	25	0	7	5
F 1130 NBR	9	16	58	30	60	5
F 3037 NBR	9	44	145	137	137	5
F 3038 NBR	9	35	155	140	140	5
F 1185 NBR	9,5	9,5	36	7	20	6
F 1044 NBR	10	10	36	18	45	6
F 1048 NBR+Si	10	20	33,5	23	45	6
F 1193 NBR	10	10	86	37	50	6
F 1236 NBR	10	10	90	20	95	6
F 1251 NBR	10	10	40	20	50	5a
F 2107 CR	10	56	160	50	140	5a
F 9011 NBR	10	25	30	12	35	5
F 4029 NBR	10,5	22	80	20	90	6
F 1037 NBR	11	11	21	10	12	7
F 1162 NBR	11	25	88	25	75	7
F 4027 NBR	11	20	50	15	43	7
F 4051 NBR	11	43	125	55	150	7
F 1010 NBR	12	16	30	8	30	8
F 1039 NBR	12	56	70	25	60	8
F 1050 NBR	12	70	121	32	150	8
F 1080 NBR	12	36	39	22	40	8



# Vulkanisierte Faltenbälge/Moulded Bellows

Ø/Dia.

<b>Art. No.</b>	<b>Kleinster Anschluss-Ø</b> Smallest inside fitting diameter Plus petit Ø intérieur de fixation Ø interior mínimo	<b>Größter Anschluss-Ø</b> Largest inside fitting diameter Le plus grand Ø intérieur de fixation Ø interior máximo	<b>Produktionslänge</b> Production length Longueur de production Longitud de suministro	<b>Lmin</b>  Length min  Longueur min  Longitud min.	<b>Lmax</b>  Length max  Longueur max  Longitud máx.	<b>Seite</b>  Page  Pagina
F 4054 NBR	12	42	100	42	110	9
F 4063 NBR	12	24	120	40	110	9
F 1104 NBR	13	33	54	12	43	9
F 1155 NBR	14	25	93	30	120	10
F 4058 NBR	14	27	184	55	230	10
F 4065 NBR	14	14	155	35	140	10
F 1060 NBR	15	62	82	25	80	11
F 1235 NBR	15	15	95	25	90	11
F 1051 NBR	16	28	116	48	120	12
F 1052 NBR	16	21	88	30	120	11
F 1139 NBR	16	22	148	48	150	12
F 1180 NBR	16	40	105	25	85	12
F 9008 NBR	16	62	40	10	25	11
F 1063 NBR	17	17	99	25	100	12
F 1177 NBR	17	23	59	15	60	12
F 1241 NBR	17	37	140	25	170	13
F 4049 NBR	17	40	62	20	41	13
F 1038 NBR	18	54	125	36	135	14
F 1144 NBR	18	44	44	6	25	14
F 1189 NBR	18	71	86	20	95	14
F 4024 NBR	18	29	50	10	28	13
F 4048 NBR	18	40	62	20	35	13
F 4047 NBR	19	40	48	10	31	14
F 1033 NBR	20	64	35	9	40	16
F 1054 NBR	20	28	94	30	140	15
F 1134 NBR	20	41	83	14	60	16
F 1149 NBR	20	20	100	25	130	15
F 1149 Si	20	20	100	25	130	15
F 1150 NBR	20	32	215	65	250	16
F 1171 NBR	20	42,5	33	0	20	15
F 1212 NBR	20	100	100	18	100	16
F 1242 NBR	20	20	155	50	180	15
F 4023 NBR	20	20	78	24	60	15
F 1013 NBR	21	32	125	45	120	17
F 1018 NBR	21	30	115	36	120	17
F 1053 NBR	21	32	40	17	30	16
F 1003 NBR	22	22	58	0	10	17
F 1006 NBR	22	27	102	32	110	18
F 1012 NBR	22	30	180	65	180	18
F 1029 NBR	22	47	67	18	56	18
F 1175 NBR	22	32	128	50	150	18
F 4043 NBR	22	36	98	30	76	17
F 1017 NBR	23	95	190	60	250	19
F 1154 NBR	23	50	35	0	31	18



# Vulkanisierte Faltenbälge/Moulded Bellows

Ø/Dia.

<b>Art. No.</b>	<b>Kleinster Anschluss-Ø</b> Smallest inside fitting diameter Plus petit Ø intérieur de fixation Ø interior mínimo	<b>Größter Anschluss-Ø</b> Largest inside fitting diameter Le plus grand Ø intérieur de fixation Ø interior máximo	<b>Produktionslänge</b> Production length Longueur de production Longitud de suministro	<b>Lmin</b>  Length min  Longueur min  Longitud min.	<b>Lmax</b>  Length max  Longueur max  Longitud máx.	<b>Seite</b>  Page  Pagina
F 4022 NBR	23	65	120	40	130	19
F 1001 NBR	24	24	93	27	55	19
F 1230 NBR	24,5	24,5	155	45	190	19
F 1153 NBR	25	50	36	18	37	20a
F 1190 NBR	25	25	20	4	23	20
F 1192 NBR	25	25	68	9	65	20
F 1215 NBR	25	25	98	28	120	20
F 1250 NBR	25	40	155	40	190	20
F 4041 NBR	25	25	145	80	200	20a
F 4068 NBR	25	38	50	18	50	20
F 1008 NBR	26	34	90	35	100	21
F 1107 NBR	26	52	102	30	150	21
F 1004 NBR	27	27	104	0	24	21
F 1043 NBR	27	42	80	15	70	22
F 1059 NBR	27	27	155	38	220	21
F 1028 NBR	28	47	64	14	55	22
F 1146 NBR	28	70	56	5	45	22
F 9001 Si	28	32	0	15	45	22
F 9009 NBR	28	82	0	35	120	21
F 1062 NBR	29	73	134	27	150	23
F 1095 NBR	29	72	150	25	200	23
F 1151 NBR	29	29	55	10	55	22
F 1152 NBR	29	32	60	20	60	22
F 1232 NBR	29	70	78	15	75	23
F 1073 NBR	30	30	145	43	190	24
F 1103 NBR	30	45	120	34	210	25
F 1114 NBR	30	30	165	77	260	24
F 1127 NBR	30	30	170	47	280	24
F 1128 NBR	30	30	135	25	160	23
F 1210 NBR	30	30	145	40	210	24
F 1238 NBR	30	30	210	75	280	25
F 1516 NBR	30	54	155	56	162	26
F 4020 NBR	30	30	75	20		25
F 4067 NBR	30	38	70	23	60	25
F 1057 NBR	32	36	194	43	180	26
F 1058 NBR	32	38	183	40	210	27
F 1099 NBR	32	54	36	8	70	27
F 1115 NBR	32	47	210	74	280	27
F 1119 NBR	32	32	83	28	95	26
F 1075 NBR	33	45	140	35	240	28
F 1206 NBR	33	35	200	55	300	27
F 1072 NBR	34	34	130	38	165	28
F 1020 NBR	35	43	180	52	220	29
F 1087 NR	35	35	140	37	240	28



# Vulkanisierte Faltenbälge/Moulded Bellows

Ø/Dia.

<b>Art. No.</b>	<b>Kleinster Anschluss-Ø</b> Smallest inside fitting diameter Plus petit Ø intérieur de fixation Ø interior mínimo	<b>Größter Anschluss-Ø</b> Largest inside fitting diameter Le plus grand Ø intérieur de fixation Ø interior máximo	<b>Produktionslänge</b> Production length Longueur de production Longitud de suministro	<b>Lmin</b>  Length min  Longueur min  Longitud min.	<b>Lmax</b>  Length max  Longueur max  Longitud máx.	<b>Seite</b>  Page  Pagina
F 1158 NBR	35	49	108	16	90	29
F 1209 NBR	35	35	164	47	210	28
F 1249 NBR	35	35	230	84	354	29
F 4018 NBR	35	70	180	55	200	29
F 4019 NBR	35	70	250	70	330	30
F 4040 NBR	35	113/106	100	35	90	30
F 1234 NBR	36	41	180	55	165	30
F 1521 NBR	36	39	340	120	560	31
F 4017 NBR	36	36	111	30	86	31
F 1026 NBR	37	56	75	25	130	31
F 1036 NBR	37	40	125	43	160	31
F 1176 NBR	38	69	135	39	210	32
F 1214 NBR	38	38	46	13	60	32
F 4015 NBR	38	38	80	30	70	32
F 4016 NBR	38	41	88	30	77	33
F 4066 NBR	38	38	120	28	130	32
F 1014 NBR	39	39	200	80	240	34
F 1231 NBR	39	52	137	40	150	33
F 3010 NBR	39	53	145	55	150	33
F 3012 NBR	39	45	165	0	0	33
F 1040 NBR	40	40	115	28	205	34
F 1064 NBR	40	45	90	20	130	35
F 1105 CR	40	55	210	70	440	36
F 1135 NBR	40	40	170	33	205	35
F 1157 NBR	40	48	115	27	180	36
F 1233 NBR	40	40	200	55	280	35
F 4014 NBR	40	52	40	15		34
F 4039 NBR	40	71	380	120	520	35
F 4061 NBR	40	48	544	180	560	34
F 1002 NBR	41	41	118	0	46	36
F 1005 NBR	41	41	162	0	0	36
F 1083 NBR	43	54	103	20	140	37
F 1078 NBR	44	55	110	22	125	37
F 1125 NBR	45	45	45	10	25	37
F 1137 NBR	45	45	97	30	75	37
F 1202 NBR	45	45	123	33	145	37
F 1223 NBR	45	45	180	40	230	38
F 1229 NBR	45	45	210	55	270	38
F 1246 NBR	45	60	210	50	240	39
F 1522 NBR	45	70	192	72	500	39
F 4038 NBR	45	45	82	35	58	38
F 4069 NBR	45	45	145	45	175	38
F 9003 NBR	45	65,5	30	5	15	38
F 1188 NBR	46	60	160	60	220	40





# Vulkanisierte Faltenbälge/Moulded Bellows

Ø/Dia.

<b>Art. No.</b>	<b>Kleinster Anschluss-Ø</b> Smallest inside fitting diameter Plus petit Ø intérieur de fixation Ø interior mínimo	<b>Größter Anschluss-Ø</b> Largest inside fitting diameter Le plus grand Ø intérieur de fixation Ø interior máximo	<b>Produktionslänge</b> Production length Longueur de production Longitud de suministro	<b>Lmin</b>  Length min  Longueur min  Longitud min.	<b>Lmax</b>  Length max  Longueur max  Longitud máx.	<b>Seite</b>  Page  Pagina
F 4013 NBR	46	65	250	80	350	39
F 1132 NBR	47	65	112	24	160	39
F 1025 NBR	48	66	66	15	65	40
F 1030 NBR	48	84	100	42	90	40
F 1123 NBR	48	48	280	140	450	40
F 1126 NBR	49	49	320	140	510	41
F 1160 NBR	49	75	85	10	60	41
F 1173 NBR	49	49	102	30	55	41
F 1055 NBR	50	63	116	50	240	42
F 1112 NBR	50	50	172	68	185	42
F 1141 NBR	50	50	210	40	300	42
F 1205 NBR	50	50	125	40	160	41
F 1208 NBR + Si	50	56	155	45	180	42
F 4012 NBR	50	50	330	100	635	43
F 4037 NBR	50	94	80	50	180	43
F 9010 NBR	50	155	120	20	100	43
F 1245 NBR	51	51	210	60	280	43
F 1016 NBR	52	52	195	75	230	44
F 1191 NBR	52	52	78	15	85	45
F 2015 NBR	52	52	115	35	120	44
F 1252 NBR	53,5	90	235	110	300	44
F 1076 NBR	54	54	210	70	400	44
F 1248 NBR	55	55	210	70	280	45
F 2006 NBR	55	55	65	0	0	45
F 4011 NBR	55	70	250	90	300	45
F 1182 NBR	56	56	130	45	145	46
F 4010 NBR	56	86	260	90	320	46
F 1021 NBR	58	61	130	25	180	46
F 4009 NBR	59	151	150	60	160	46
F 1027 NBR	60	60	130	30	170	47
F 2001 NBR + Si	60	60	235	45	300	48
F 1031 NBR	60	70	300	80	385	47
F 1147 NBR	60	130	170	40	240	48
F 1207 NBR	60	60	205	52	260	47
F 4008 NBR	60	60	146	45	220	48
F 9004 NBR	60	86	39,5	5	15	47
F 1244 NBR	62	62	150	56	200	49
F 9002 NBR	62	62	70	15	80	48
F 1159 NBR	64	84	95	20	150	49
F 1239 NBR	64	82	125	35	130	49
F 1222 NBR	65	65	200	40	300	49
F 4064 NBR	65	86	190	50	200	50
F 1088 NBR	67	75	80	23	150	50
F 4005 NBR	67	67	90	20	40	50



# Vulkanisierte Faltenbälge/Moulded Bellows

Ø/Dia.

<b>Art. No.</b>	<b>Kleinster Anschluss-Ø</b> Smallest inside fitting diameter Plus petit Ø intérieur de fixation Ø interior mínimo	<b>Größter Anschluss-Ø</b> Largest inside fitting diameter Le plus grand Ø intérieur de fixation Ø interior máximo	<b>Produktionslänge</b> Production length Longueur de production Longitud de suministro	<b>Lmin</b>  Length min  Longueur min  Longitud min.	<b>Lmax</b>  Length max  Longueur max  Longitud máx.	<b>Seite</b>  Page  Pagina
F 1091 NBR	70	70	80	40	40	50
F 1148 NBR	70	70	100	20	160	50
F 1186 NBR	70	70	290	74	420	51
F 1211 NBR	70	70	205	52	260	51
F 1528 NBR	70	84	168	52	250	51
F 4003 NBR	70	70	300	120	500	52
F 4004 NBR	70	88	260	90	320	52
F 1169 NBR	71	71	38	4	14	51
F 1049 NBR	72	90	120	0	0	53
F 1061 NBR	72	75	50	13	80	52
F 1096 NBR	73	73	36	7	45	52
F 1109 NBR	74	74	105	29	180	53
F 2067 NBR	74	74	75	18	100	53
F 1179 NBR	75	75	210	75	340	54
F 2075 NBR	75	75	245	50	345	54
F 4057 NBR	75	75	134	40	140	53
F 4002 NBR	79	110	130	35	120	54
F 1164 NBR	80	80	230	70	240	55
F 1197 NBR	80	80	230	50	330	55
F 1224 NBR	80	80	210	50	250	55
F 4001 NBR	80	85	160	50	130	55
F 1225 NBR	81	81	85	15	100	56
F 1118 NBR	85	85	60	13	120	57
F 1201 CR	85	85	285	55	460	56
F 1201 NBR	85	85	285	55	460	56
F 1221 NBR	85	85	210	40	260	56
F 1071 NBR	90	90	88	31	190	57
F 1090 NBR	90	90	80	12	95	57
F 1217 NBR	90	90	210	50	320	57
F 1089 NBR	92	118	90	31	200	57
F 1070 NBR	95	95	100	38	190	58
F 1237 NBR	95	95	220	60	310	58
F 1111 NBR	98	98	100	18	140	58
F 1113 NBR+Si	98	98	80	12	85	58
F 1074 NBR	100	100	105	33	200	59
F 1218 NBR	100	100	200	40	250	59
F 4059 NBR	100	100	353	90	350	59
F 9000 NBR	100	140	150	28	200	58
F 4056 NBR	105	105	130	30	110	60
F 1085 NBR	110	155	67	14	90	60
F 1216 NBR	110	110	225	60	280	60
F 4060 NBR	110	110	131	50	125	60
F 1068 NBR	114	116	170	43	250	61
F 1172 NBR	120	120	230	57	400	61



## Vulkanisierte Faltenbälge/Moulded Bellows

Ø/Dia.

<b>Art. No.</b>	<b>Kleinster Anschluss-Ø</b> <i>Smallest inside fitting diameter</i> Plus petit Ø intérieur de fixation Ø interior mínimo	<b>Größter Anschluss-Ø</b> <i>Largest inside fitting diameter</i> Le plus grand Ø intérieur de fixation Ø interior máximo	<b>Produktionslänge</b> <i>Production length</i> Longuer de production Longitud de suministro	<b>Lmin</b>  <i>Length min</i>  Longueur min  <i>Longitud min.</i>	<b>Lmax</b>  <i>Length max</i>  Longueur max  <i>Longitud máx.</i>	<b>Seite</b>  Page  Pagina
F 1204 NBR	127	127	185	40	220	61
F 1170 NBR	130	130	210	55	360	62
F 1203 NBR	130	130	100	15	140	61
F 1181 NBR	137	137	310	80	550	62
F 1046 NBR	140	140	98	19	120	62
F 1110 NR	140	176	105	17	120	62
F 1082 NBR	145	150	115	32	140	63
F 1077 NBR	150	180	140	32	200	63
F 1240 NBR	150	150	280	80	470	63
F 1079 NBR	155	165	180	75	340	63
F 1066 NBR	160	186	220	45	310	64
F 1122 NBR	180	220	75	11	110	64
F 1067 NBR	210	210	200	45	350	64
F 1069 NBR	260	280	265	80	600	65



# Vulkanisierte Faltenbälge / Moulded Bellows

**Ø 3 - 4,5 mm**

**F 1092 NBR**

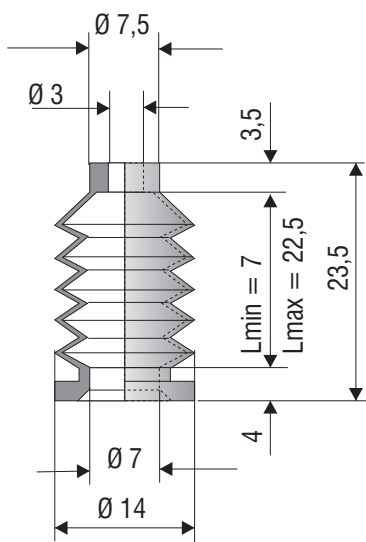

**F 1138 NBR**

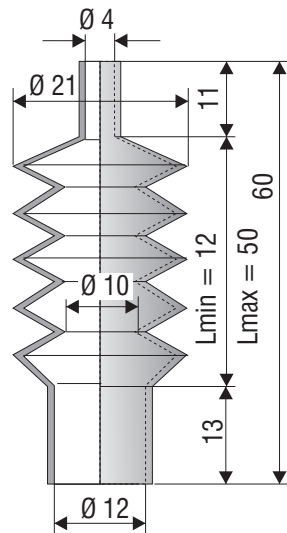

**F 1011 NBR**

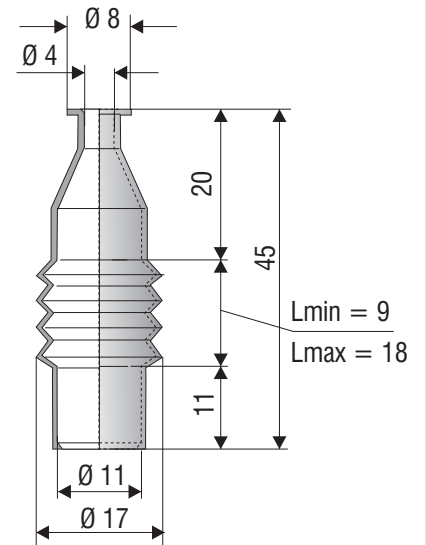

**F 1045 NBR**

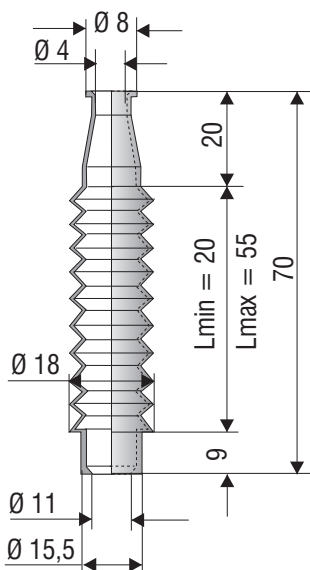

**F 1117 NBR**

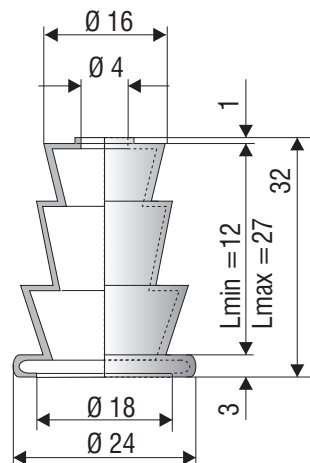

**F 1035 NBR**

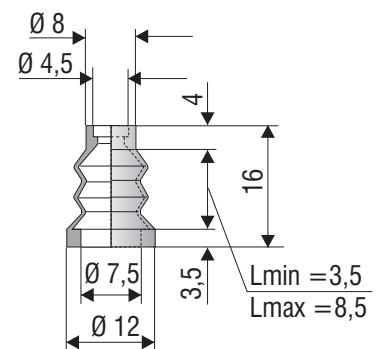



# Vulkanisierte Faltenbälge / Moulded Bellows

**Ø 4,5 - 5,5 mm**

**F 1100 NBR**

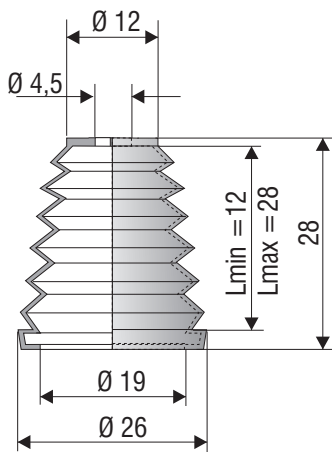

**F 1098 NBR**

schwarz/black  
grau/grey

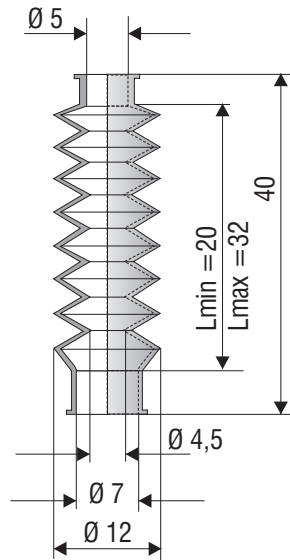

**F 1187 NBR**

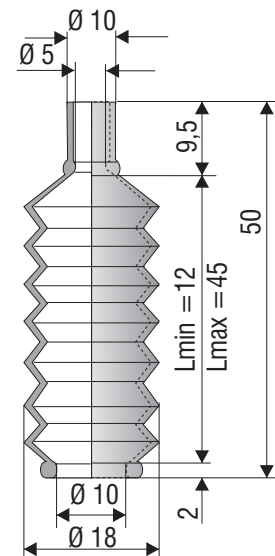

**F 1047 NBR**

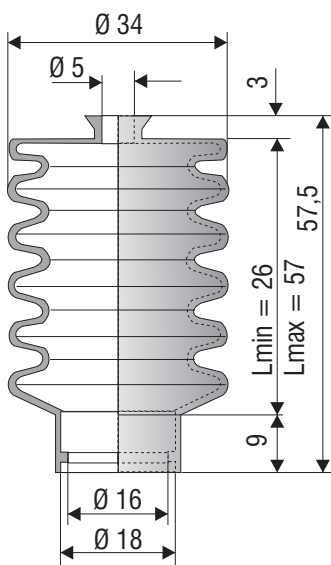

**F 1042 NBR**

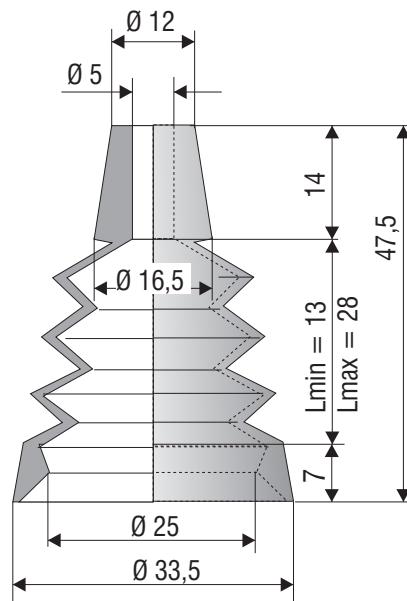

**F 4031 NBR**

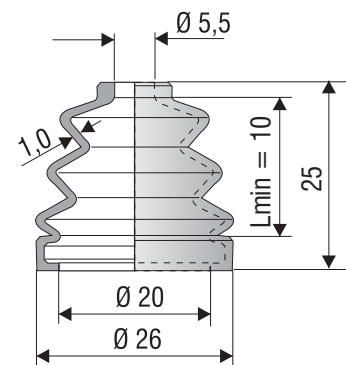



# Vulkanisierte Faltenbälge / Moulded Bellows

**Ø 6 - 7 mm**

**F 1129 NBR**

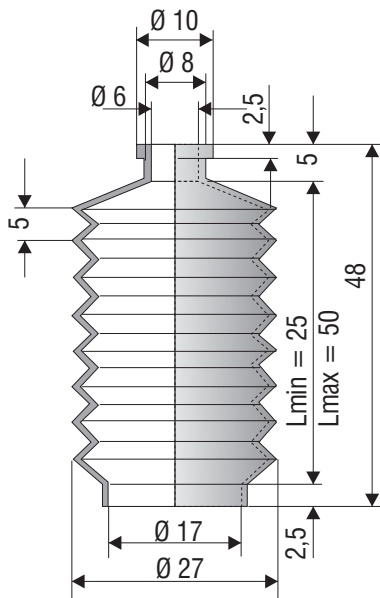

**F 1041 NBR**

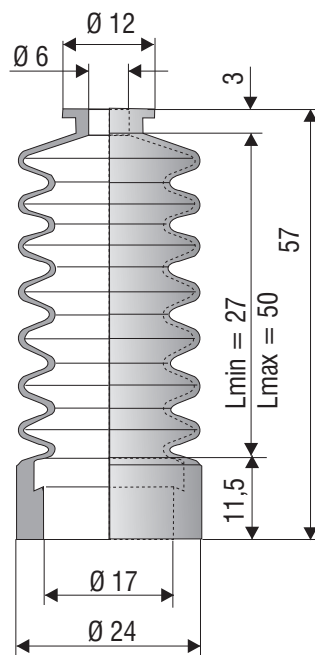

**F 1101 NBR**

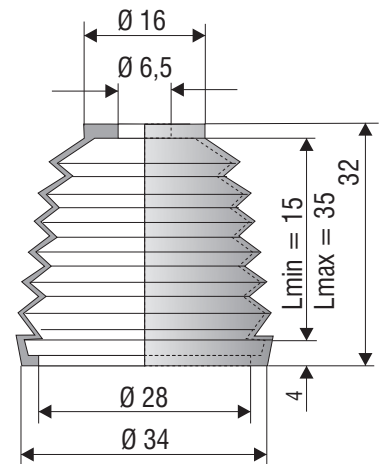

**F 1084 NBR**  
**F 1084 Si**

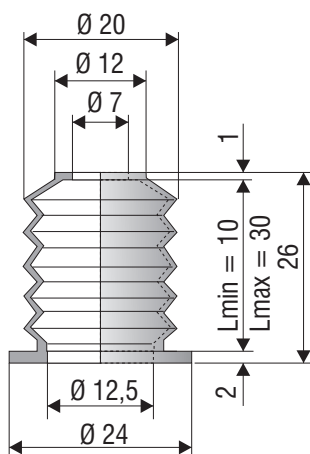

**F 1022 NBR**

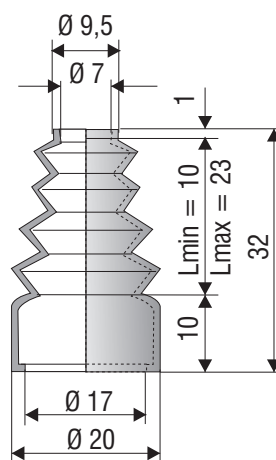

**F 1023 NBR**

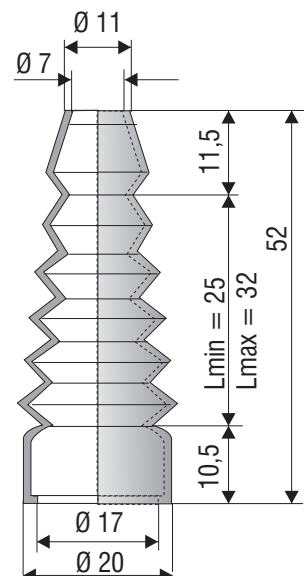



# Vulkanisierte Faltenbälge / Moulded Bellows

Ø 7 - 8 mm

**F 2231 CR**

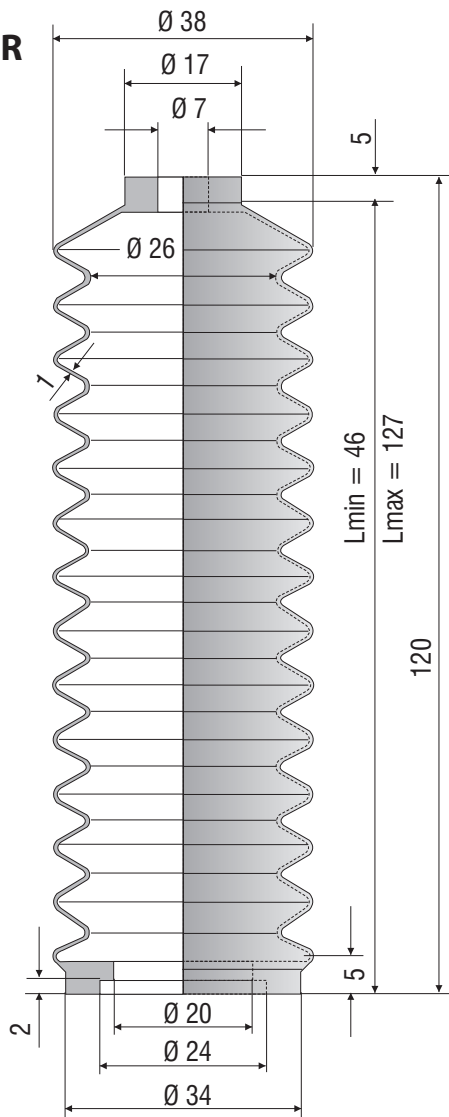

**F 2104 NBR**

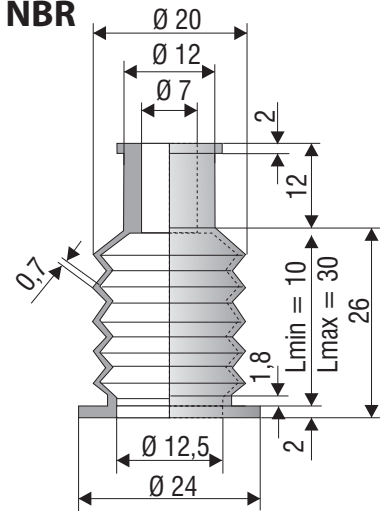

**F 1143 NBR**

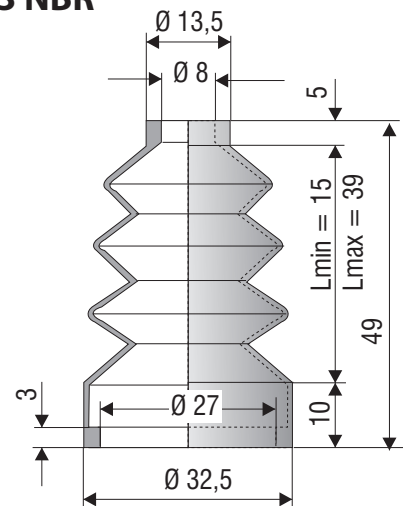

**F 1102 NBR**

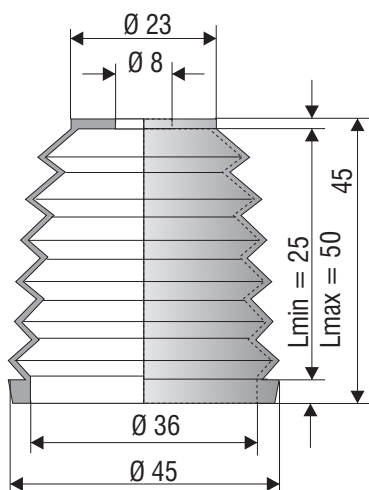

**F 1133 NBR**

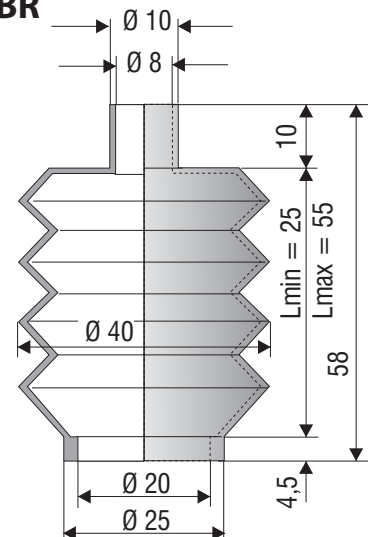





# Vulkanisierte Faltenbälge / Moulded Bellows

**Ø 9 - 10 mm**

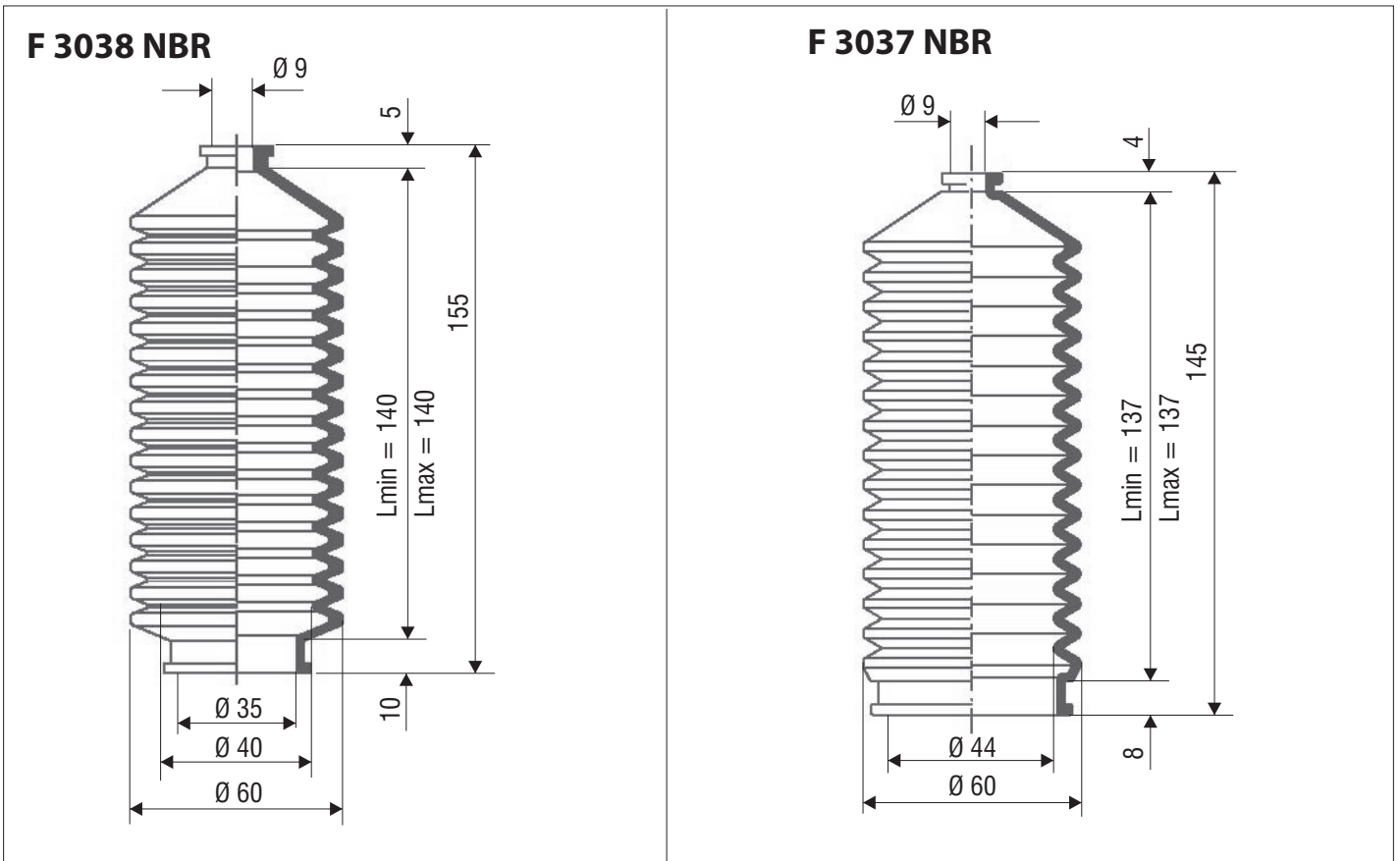
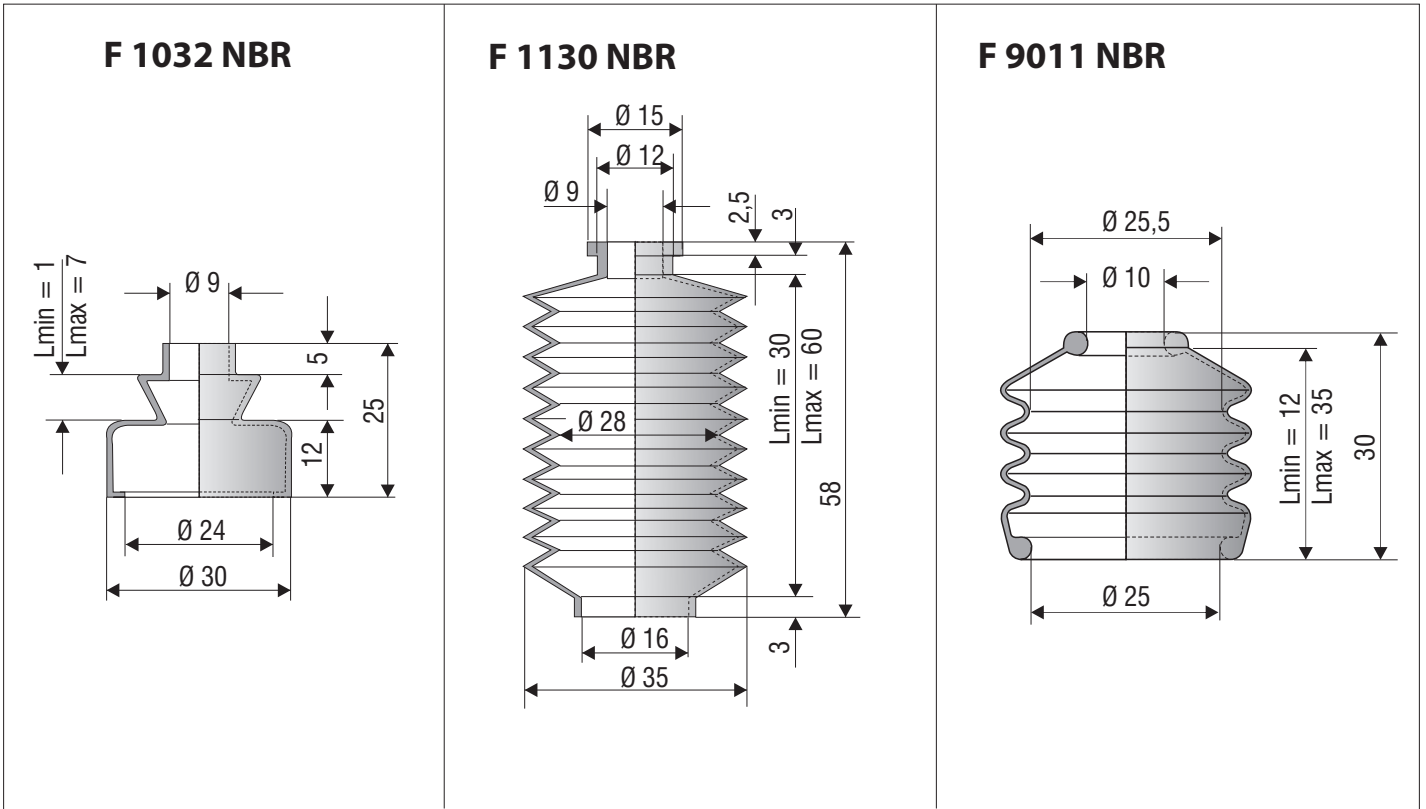



# Vulkanisierte Faltenbälge / Moulded Bellows

**Ø 9 - 10 mm**

**F 1251 NBR**

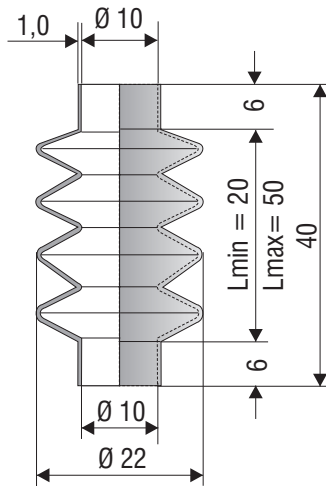

**F 2107 CR**

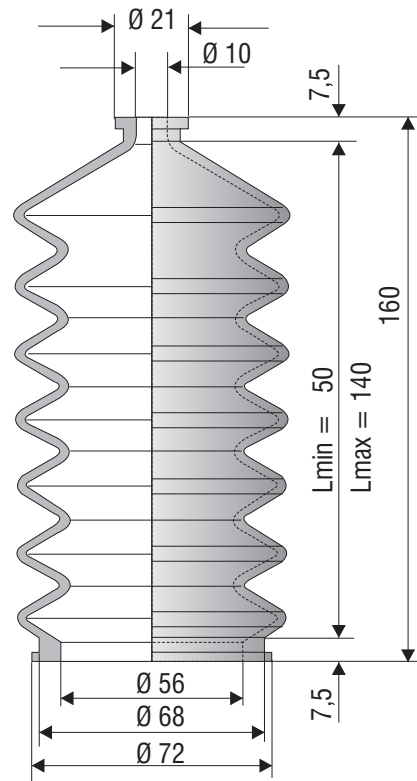



# Vulkanisierte Faltenbälge / Moulded Bellows

**Ø 9,5 - 10,5 mm**

**F 1185 NBR**

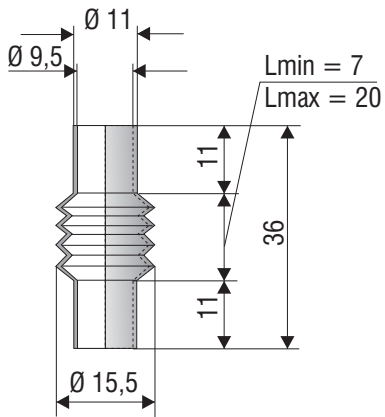

**F 1193 NBR**

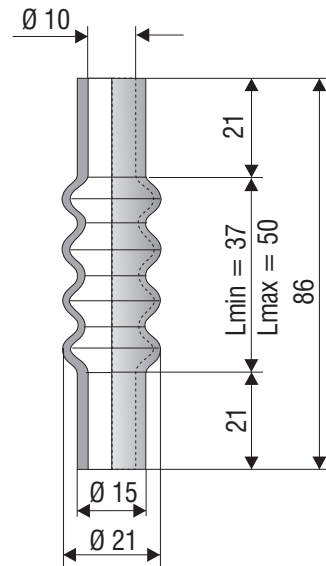

**F 1236 NBR**

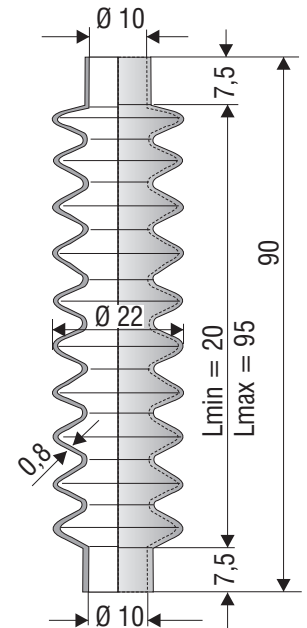

**F 1044 NBR**

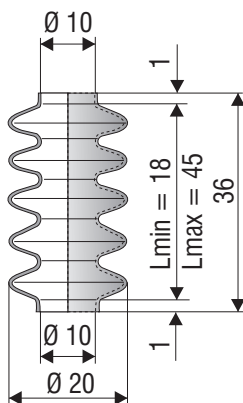

**F 4029 NBR**

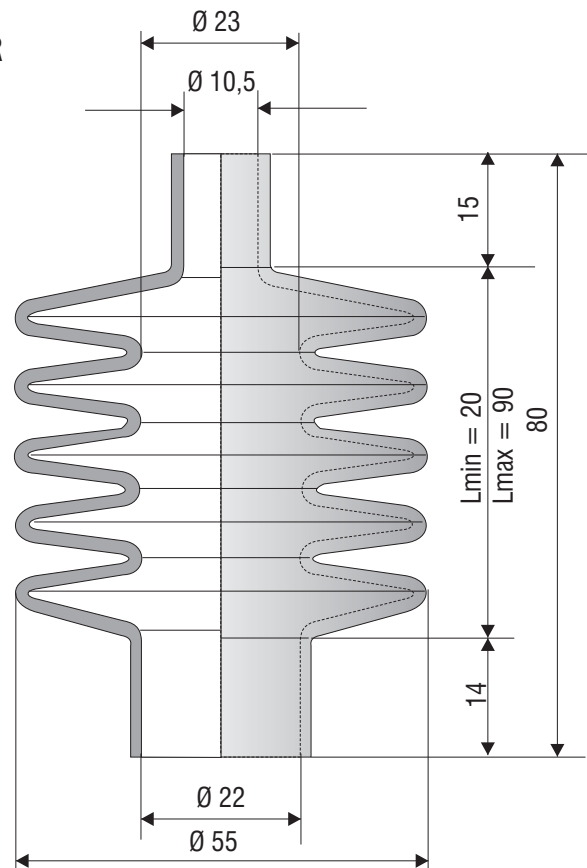

**F 1048 NBR**

**F 1048 Si**

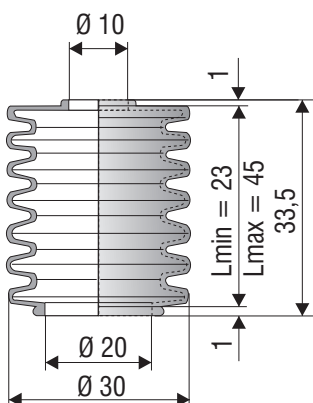



# Vulkanisierte Faltenbälge / Moulded Bellows

**Ø 11 mm**

**F 1037 NBR**

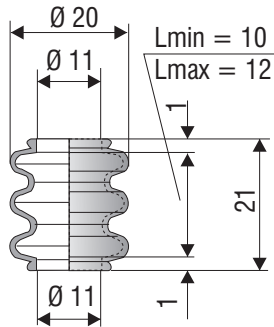

**F 4027 NBR**

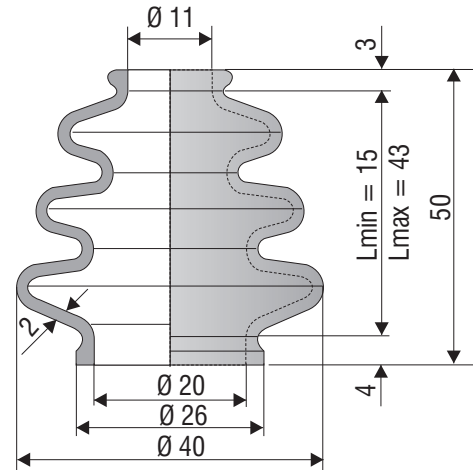

**F 1162 NBR**

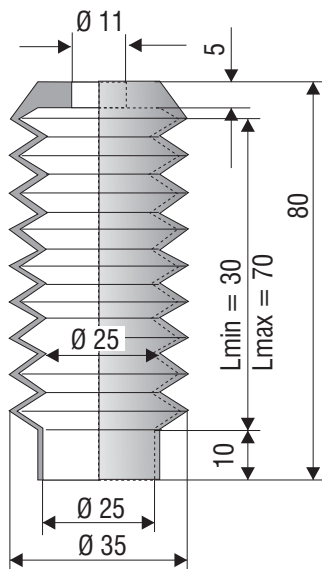

**F 4051 NBR**

9 Falten

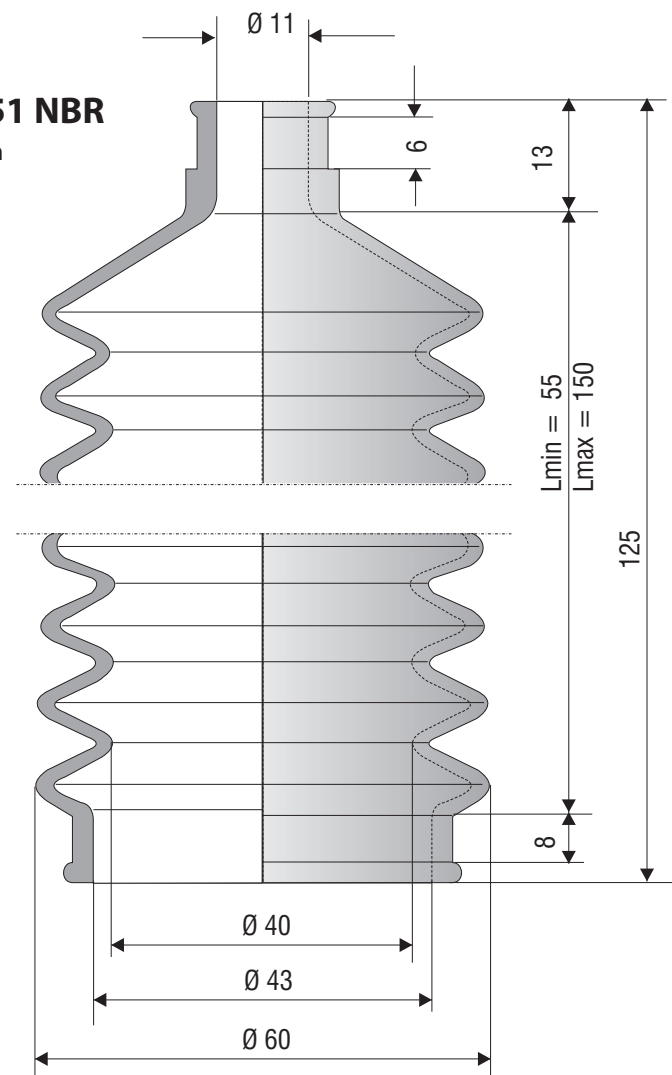



# Vulkanisierte Faltenbälge / Moulded Bellows

Ø 12 mm

**F 1010 NBR**  
**F 1010 Si**

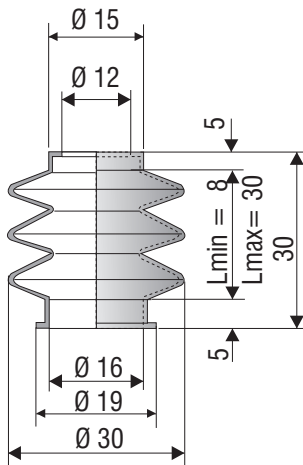

**F 1080 NBR**

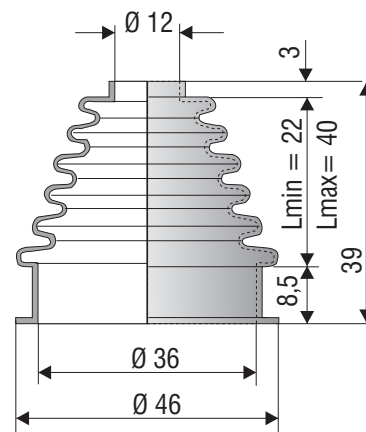

**F 1039 NBR**

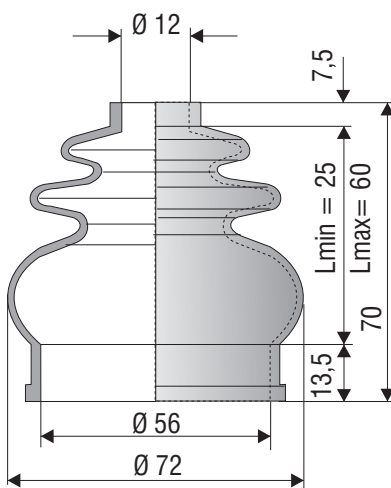

**F 1050 NBR**

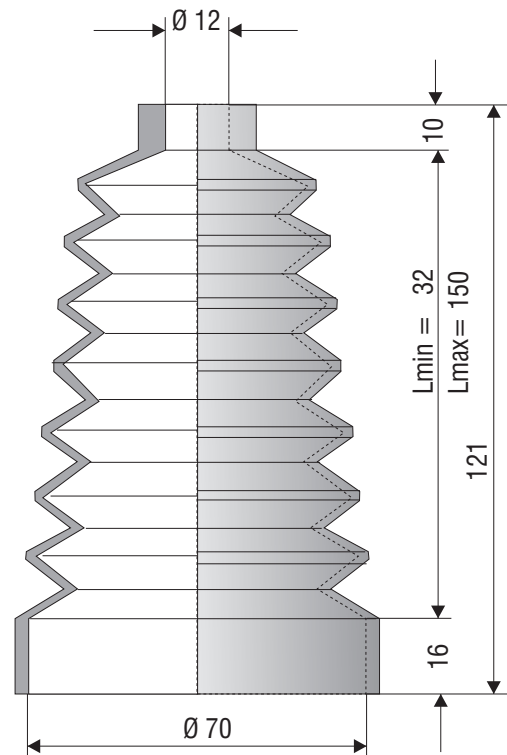



# Vulkanisierte Faltenbälge / Moulded Bellows

Ø 12 - 13 mm

**F 4054 NBR**

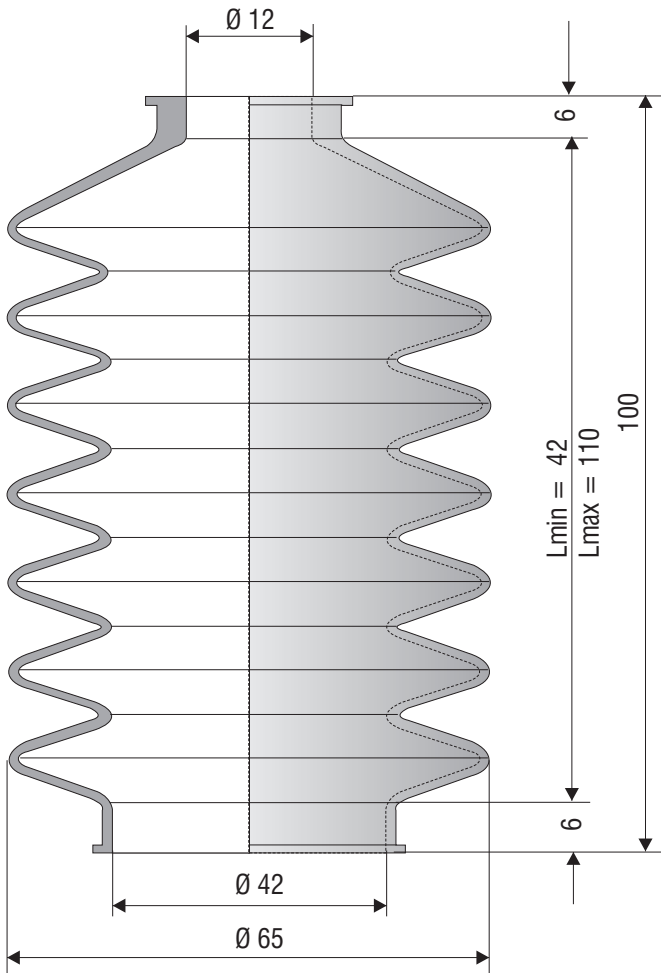

**F 4063 NBR**

11 Falten

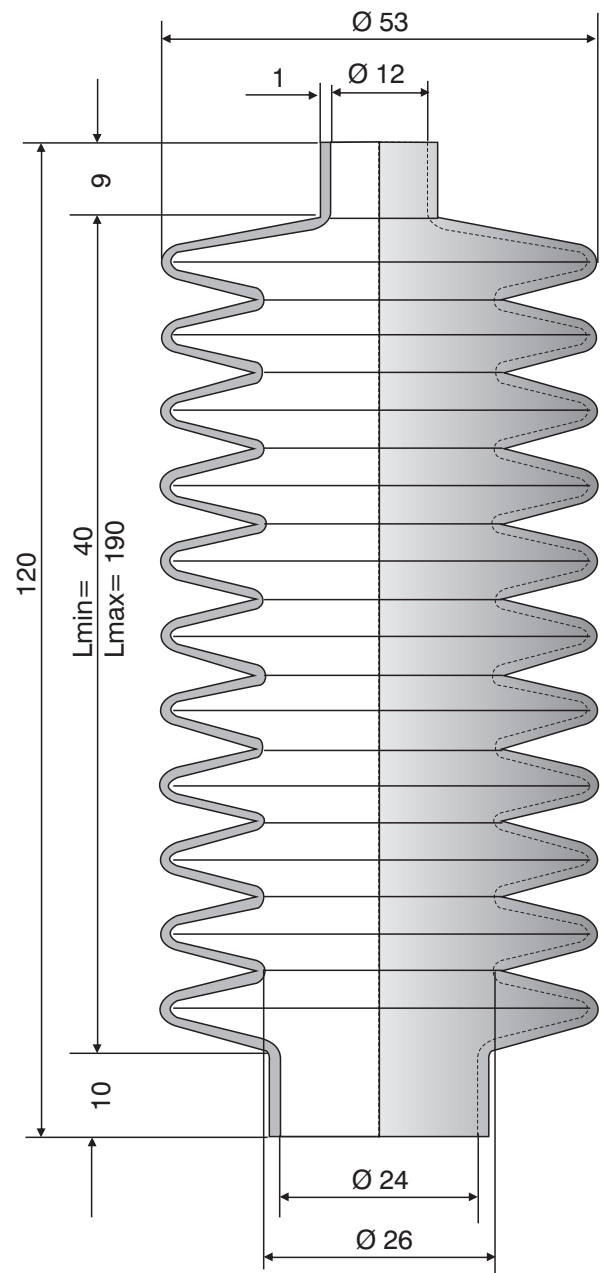

**F 1104 NBR**

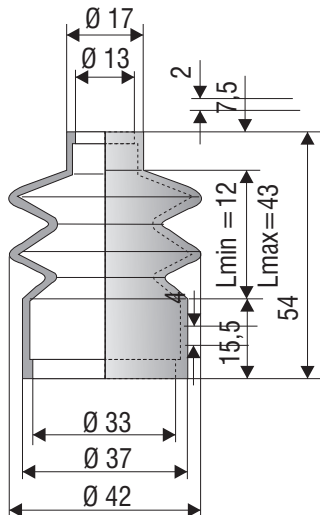



# Vulkanisierte Faltenbälge / Moulded Bellows

Ø 14 mm

**F 4065 NBR**  
20 Falten

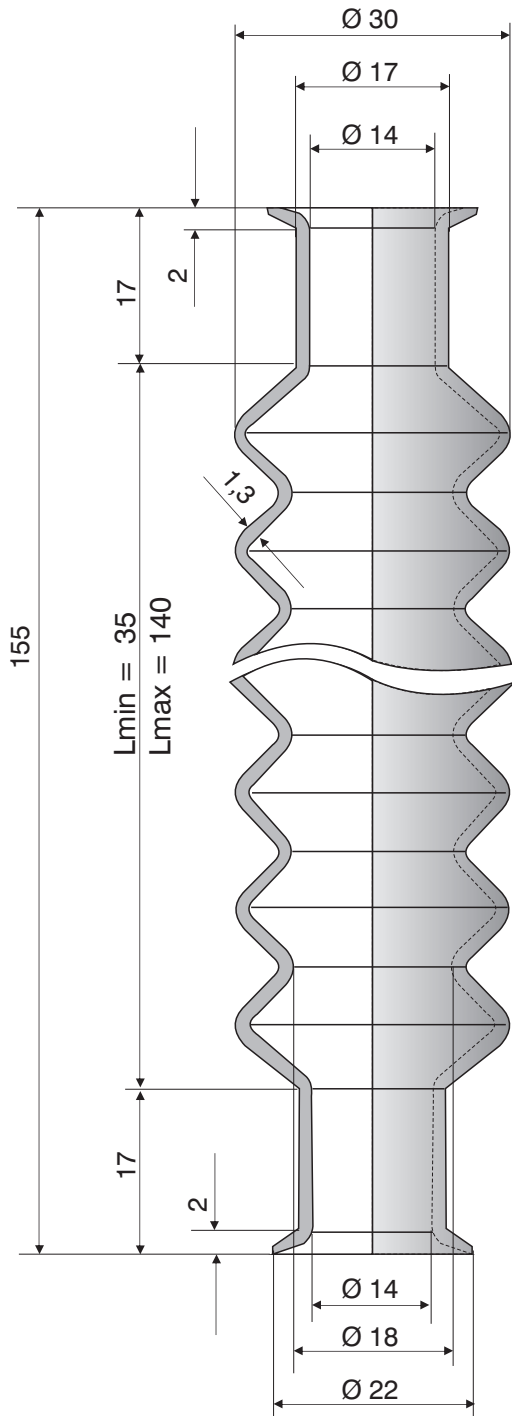

**F 1155 NBR**

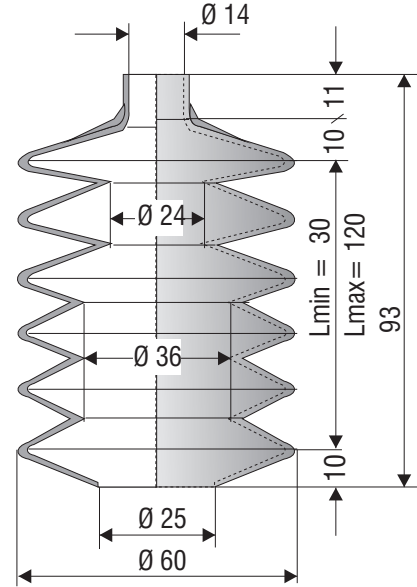

**F 4058**

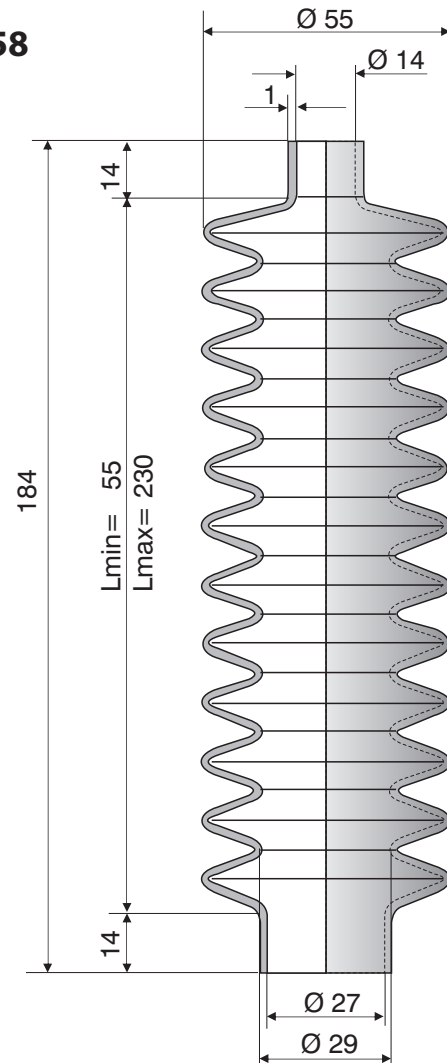





# Vulkanisierte Faltenbälge / Moulded Bellows

Ø 15 mm

**F 1235 NBR**

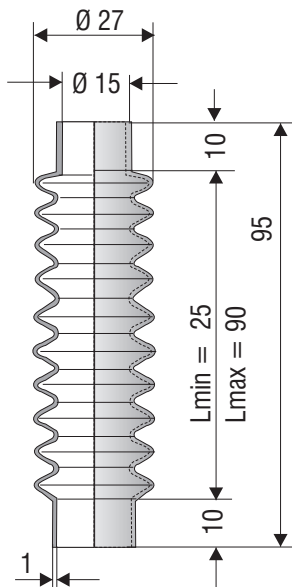

**F 1060 NBR**

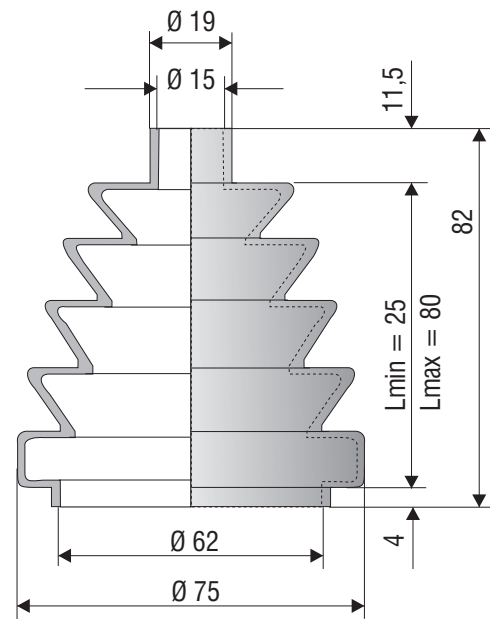

**F 9008 NBR**

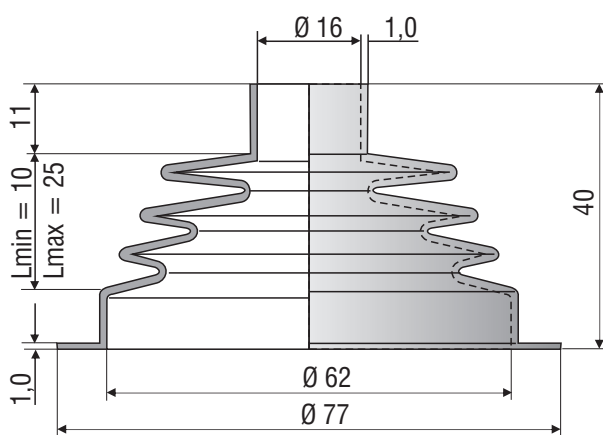

**F 1052 NBR**

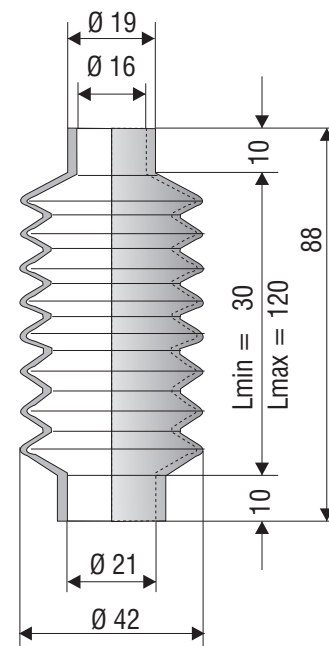



# Vulkanisierte Faltenbälge / Moulded Bellows

Ø 16 - 17 mm

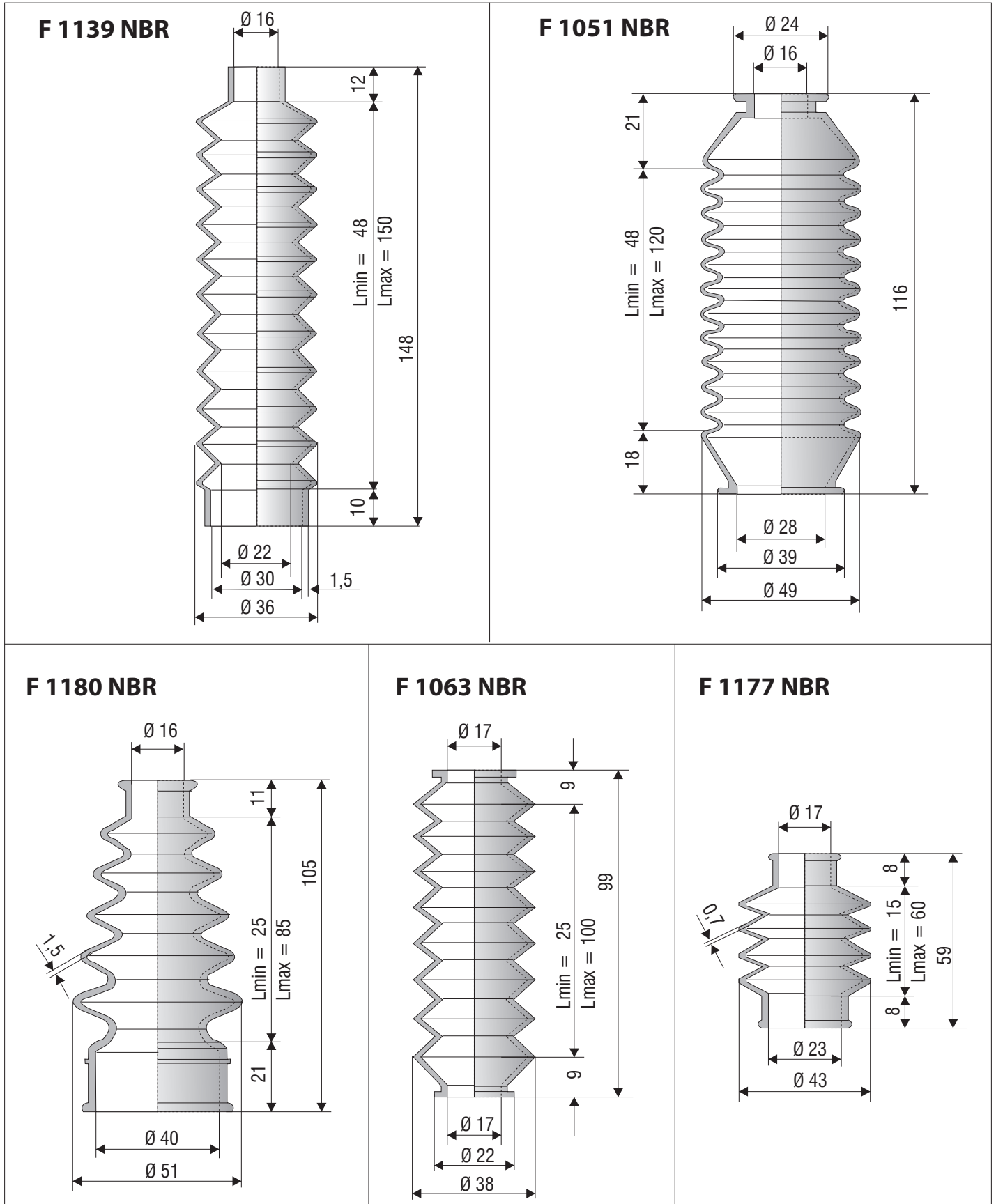



# Vulkanisierte Faltenbälge / Moulded Bellows

**Ø 17 - 18 mm**

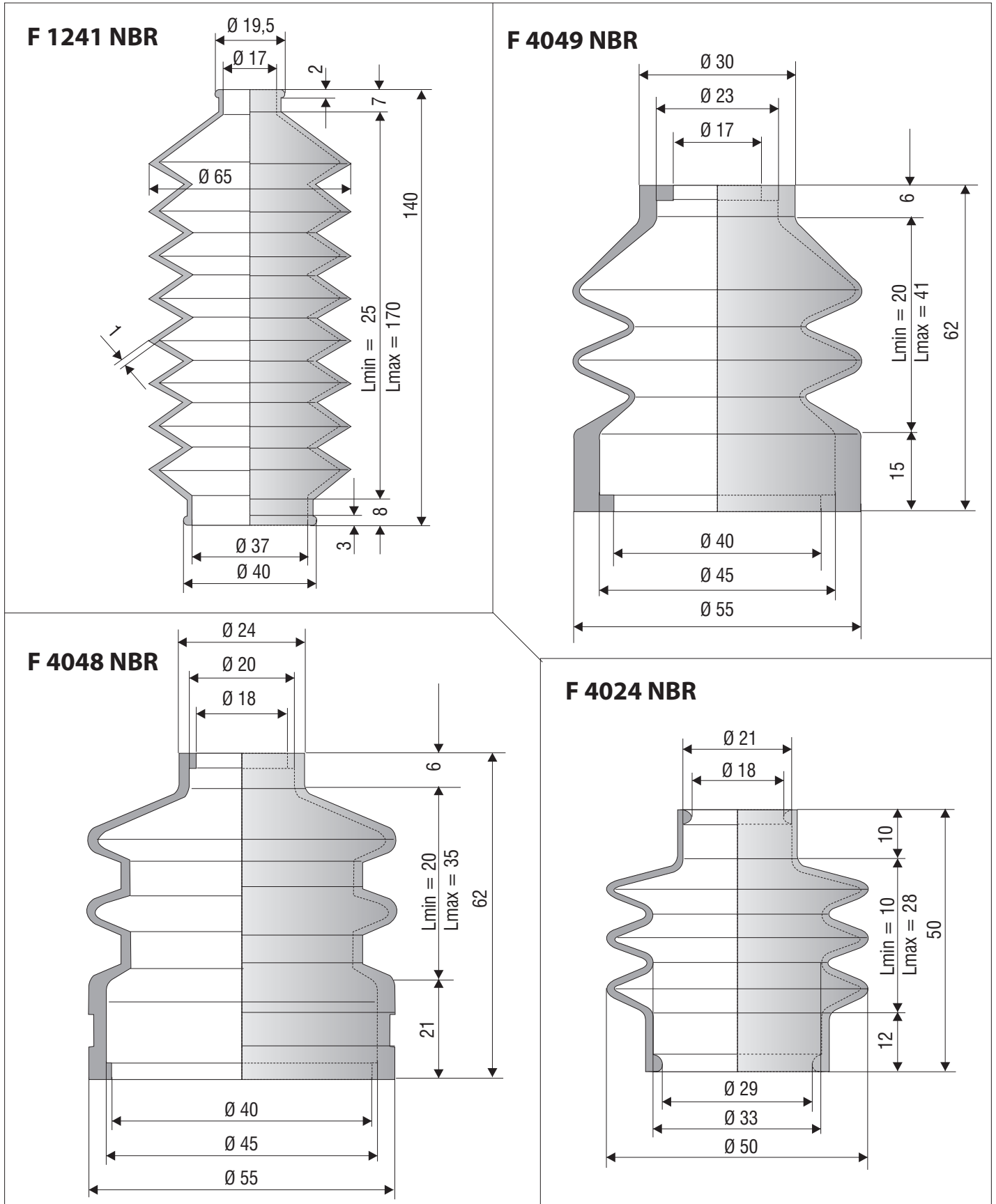



# Vulkanisierte Faltenbälge / Moulded Bellows

**Ø 18 - 19 mm**

**F 1144 NBR**

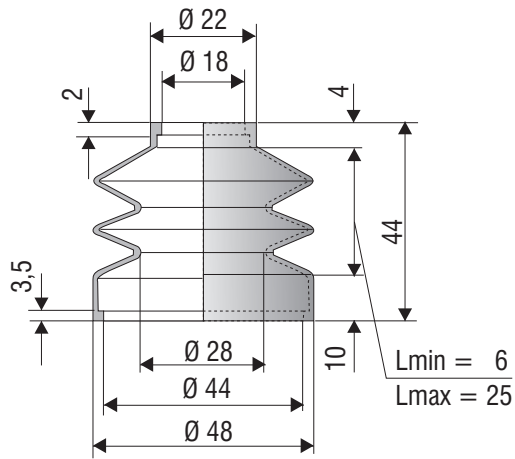

**F 1038 NBR**

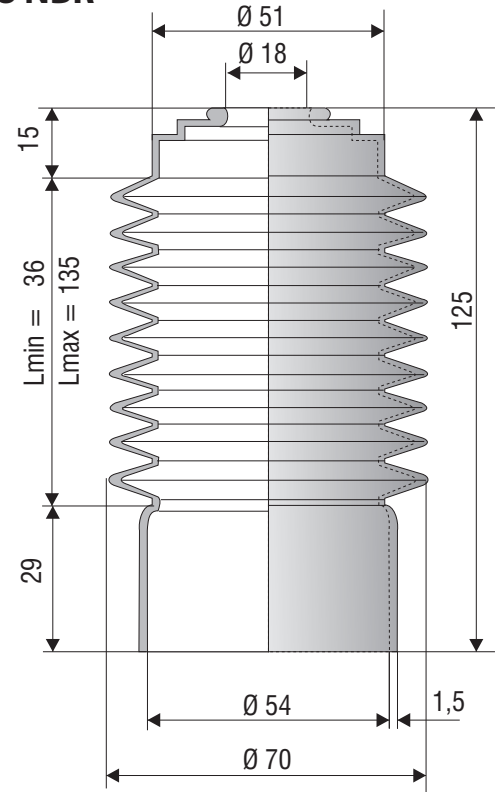

**F 1189 NBR**

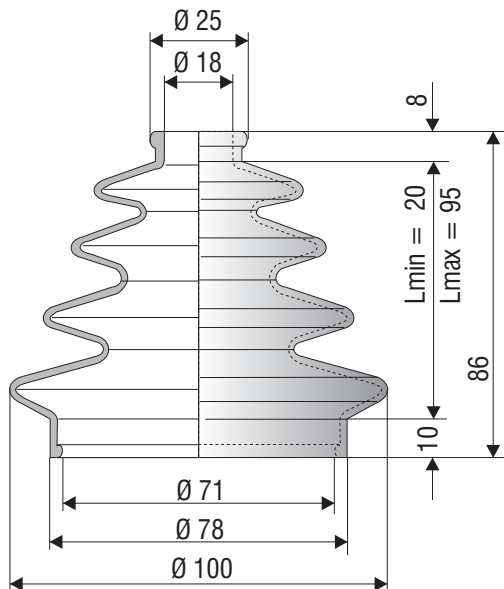

**F 4047 NBR**

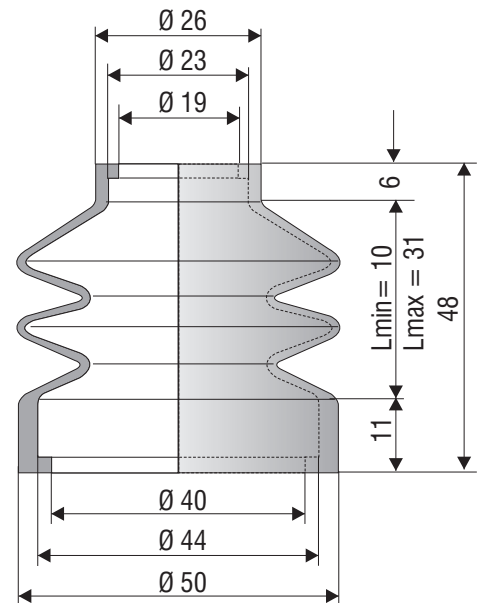



# Vulkanisierte Faltenbälge / Moulded Bellows

Ø 20 mm

**F 4023 NBR**

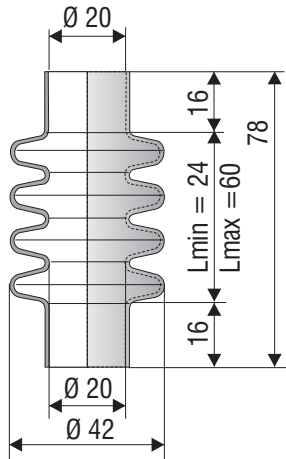

**F 1149 NBR,  
F 1149 Si,  
transparent**

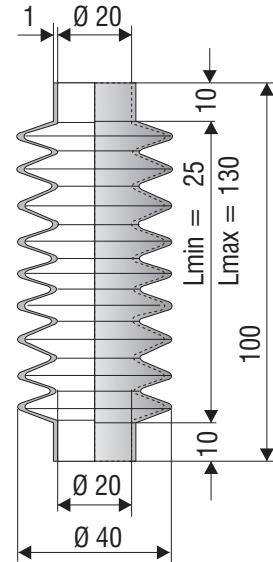

**F 1242 NBR**

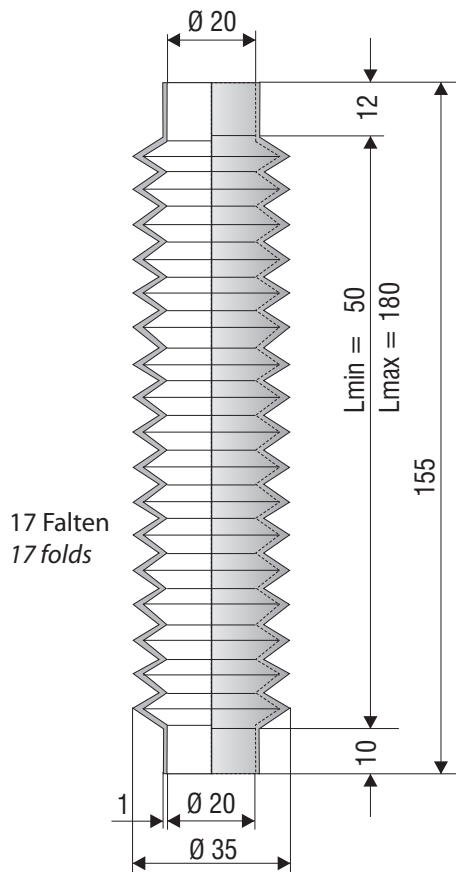

**F 1054 NBR**

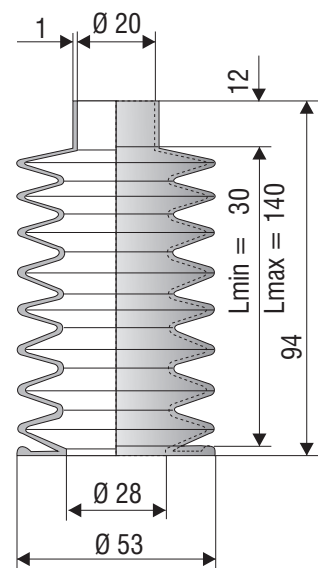

**F 1171 NBR**

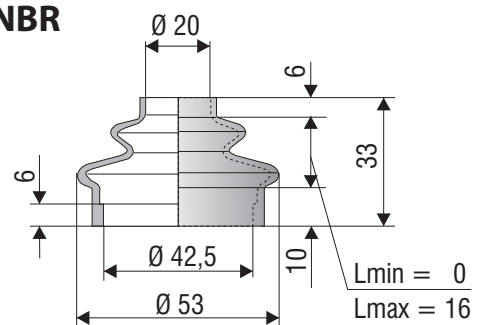



# Vulkanisierte Faltenbälge / Moulded Bellows

## Ø 20 - 21 mm

### F 1212 NBR

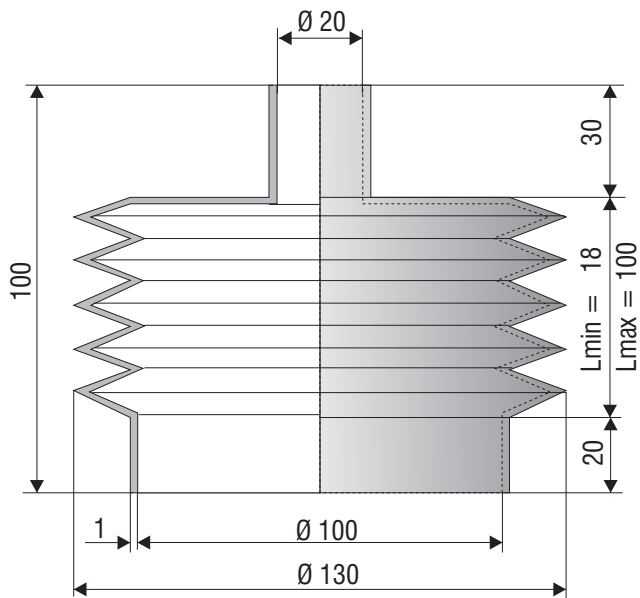

### F 1150 NBR

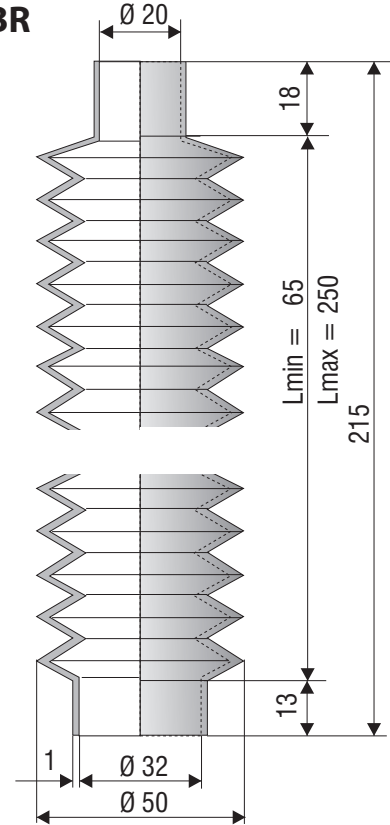

### F 1134 NBR

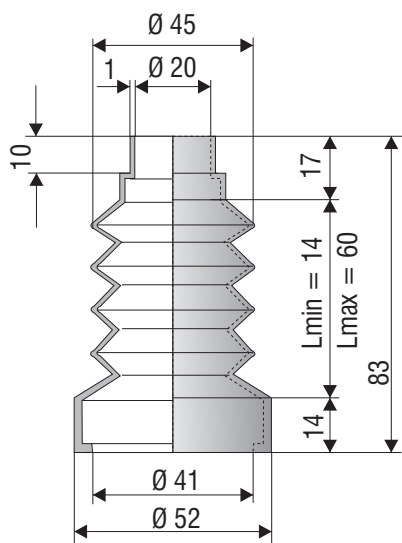

### F 1053 NBR

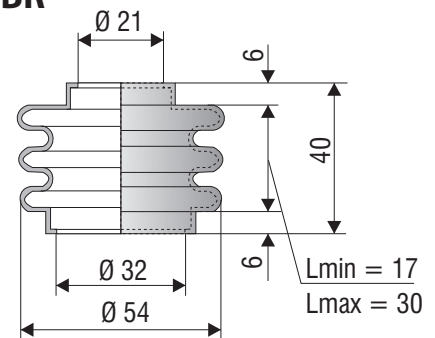

### F 1033 NBR

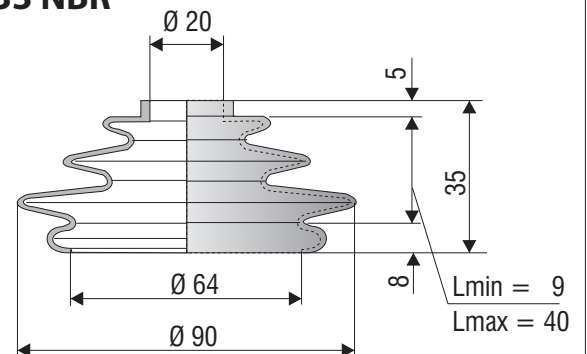



# Vulkanisierte Faltenbälge / Moulded Bellows

**Ø 21 - 22 mm**

**F 1018 NBR**

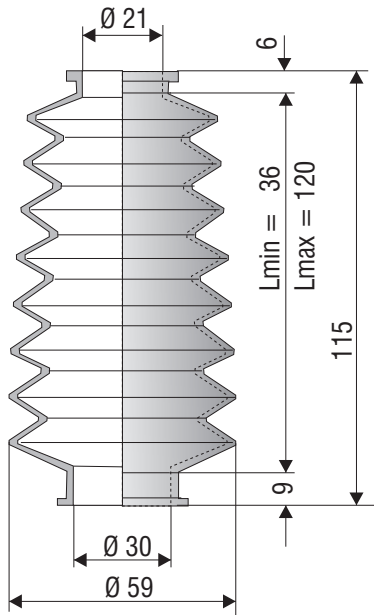

**F 1013 NBR**

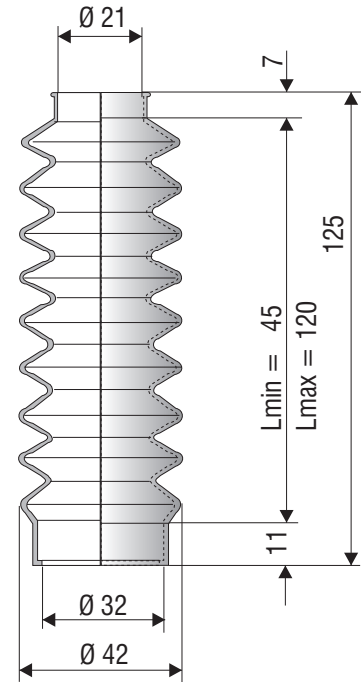

**F 4043 NBR**

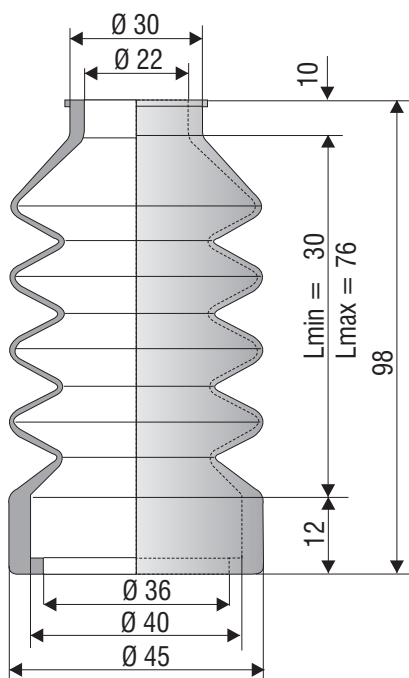

**F 1003 NBR**

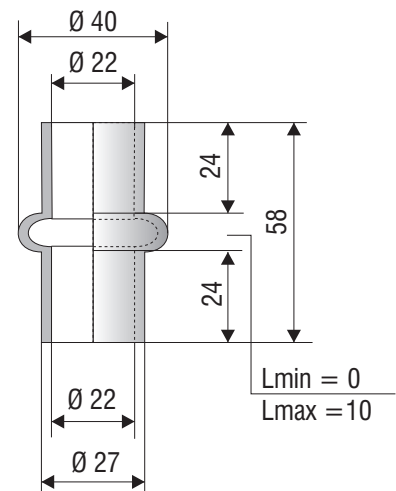





# Vulkanisierte Faltenbälge / Moulded Bellows

Ø 22- 23 mm

**F 1006 NBR**

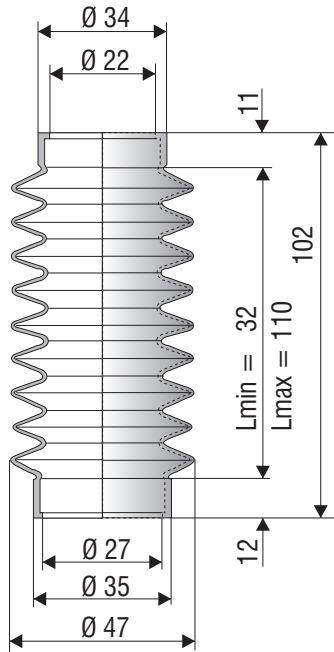

**F 1012 NBR**

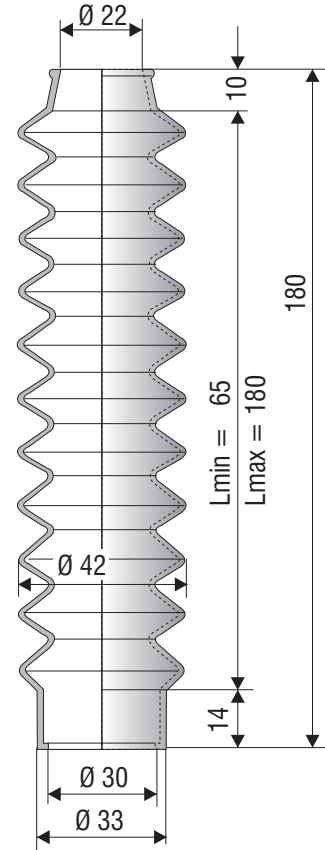

**F 1175 NBR**

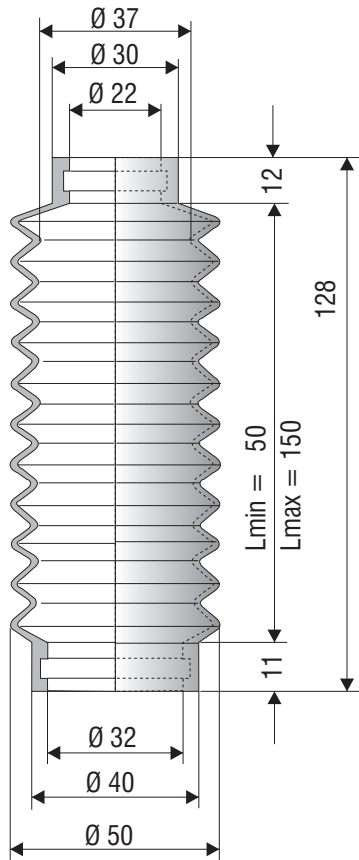

**F 1029 NBR**

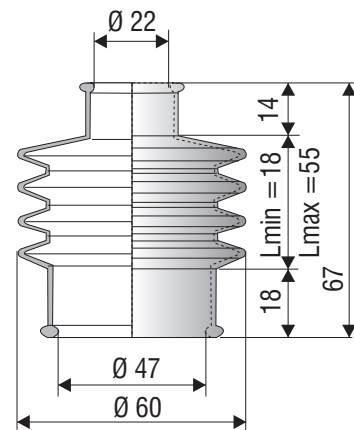

**F 1154 NBR**

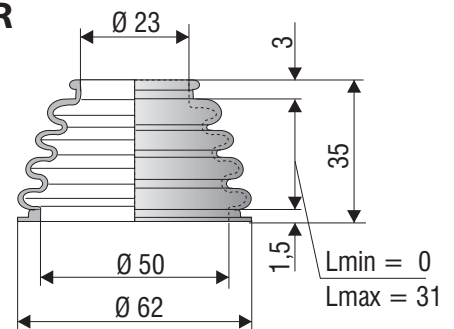



# Vulkanisierte Faltenbälge / Moulded Bellows

**Ø 23 - 24,5 mm**

**F 1001 NBR**

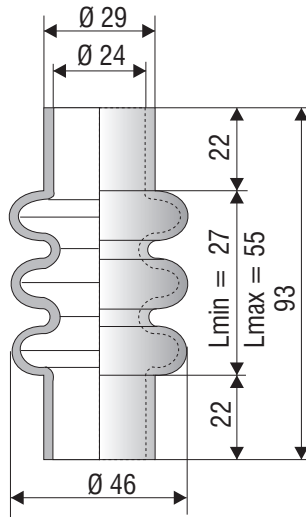

**F 4022 NBR**

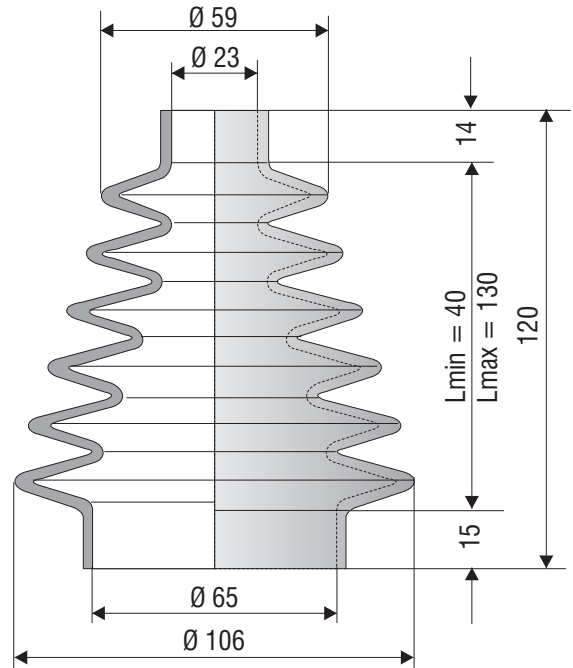

**F 1017 NBR**

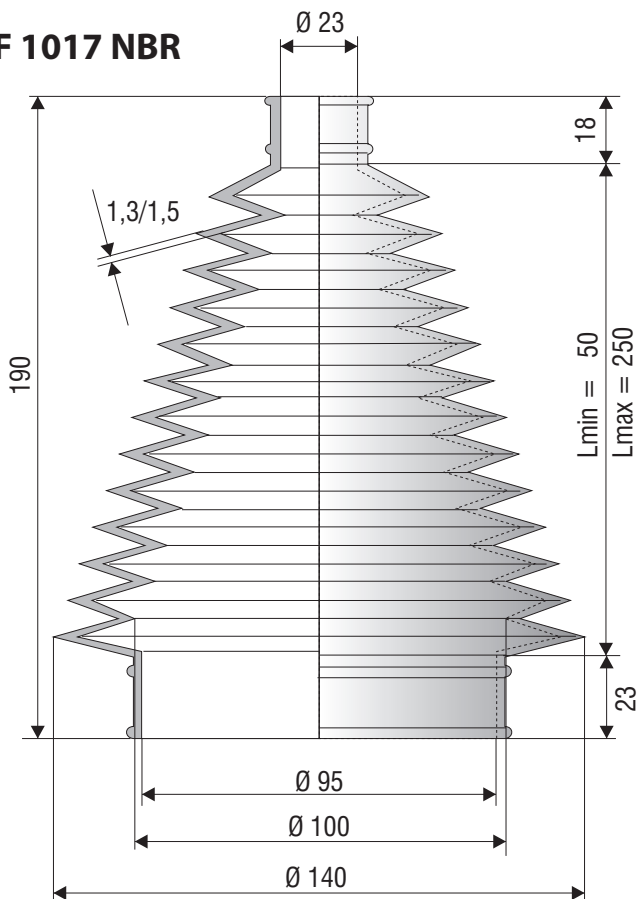

**F 1230 NBR**

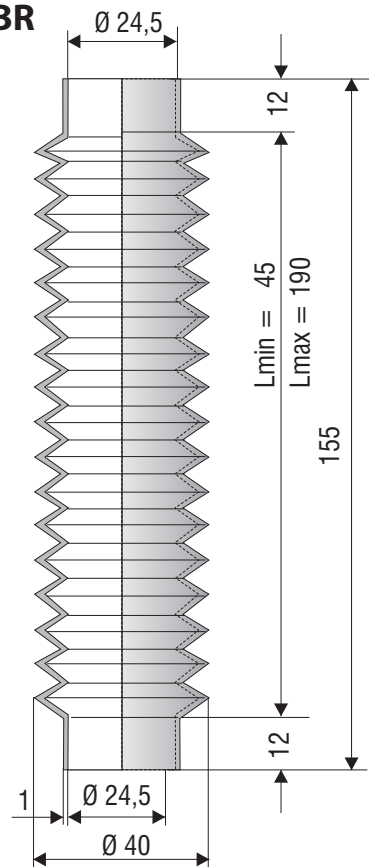



# Vulkanisierte Faltenbälge / Moulded Bellows

Ø 25 mm

**F 1190 NBR**

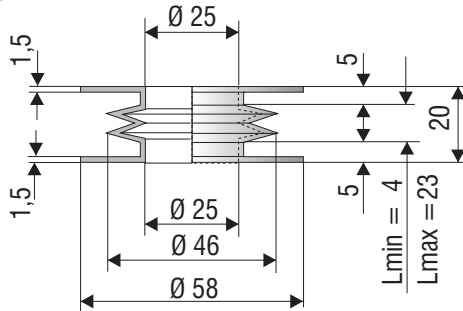

**F 1215 NBR**

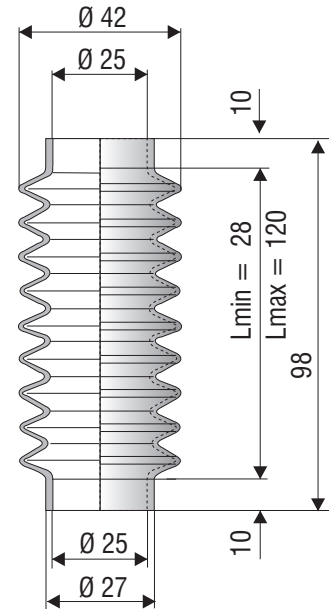

**F 1192 NBR**

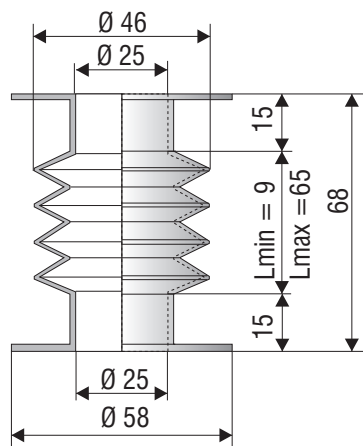

**F 1250 NBR**

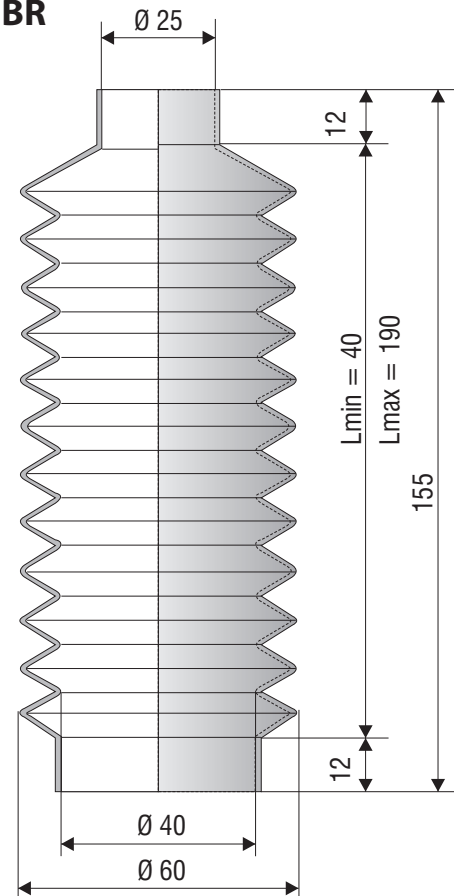

**F 4068 NBR**

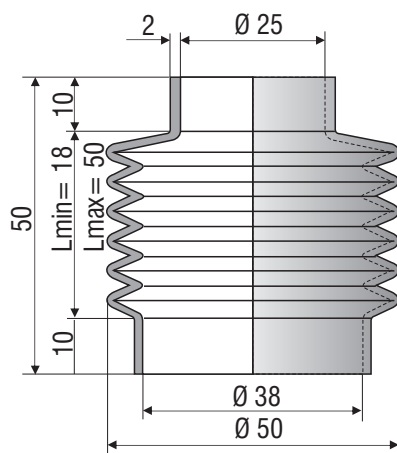



# Vulkanisierte Faltenbälge / *Moulded Bellows*

**Ø 25 mm**

**F 1153 NBR**

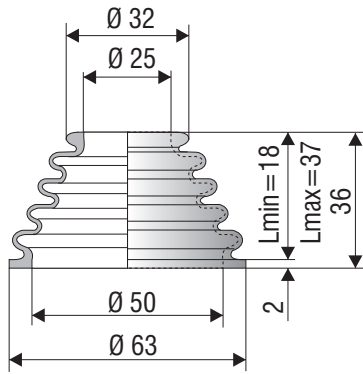

**F 4041 NBR**

19 Falten

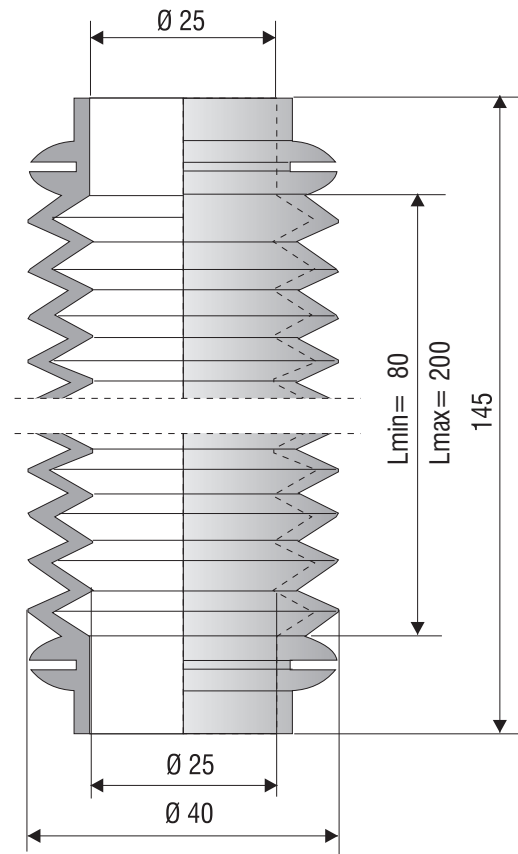



# Vulkanisierte Faltenbälge / Moulded Bellows

Ø 26 -28 mm

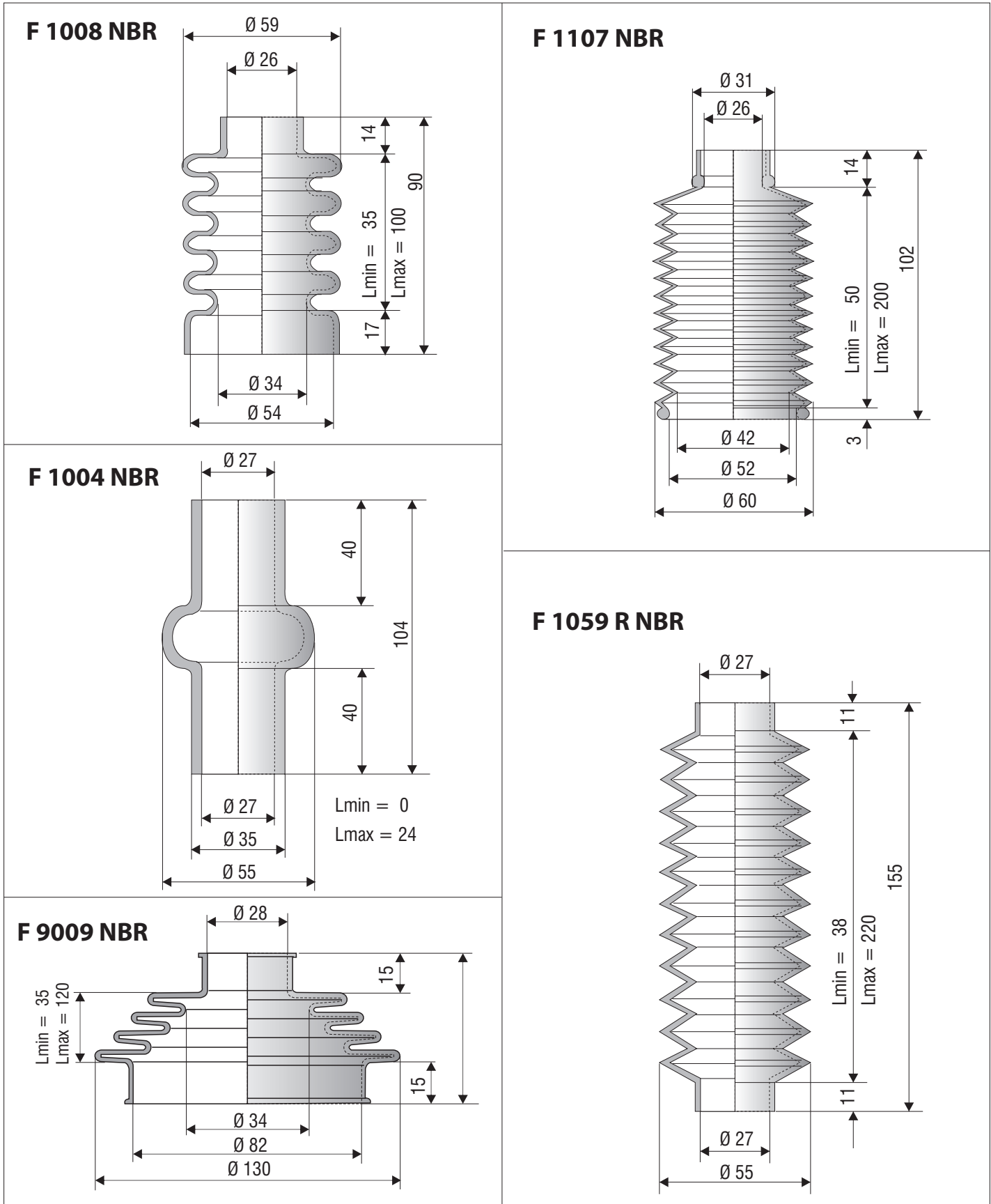



# Vulkanisierte Faltenbälge / Moulded Bellows

**Ø 27 - 29 mm**

**F 1043 NBR**

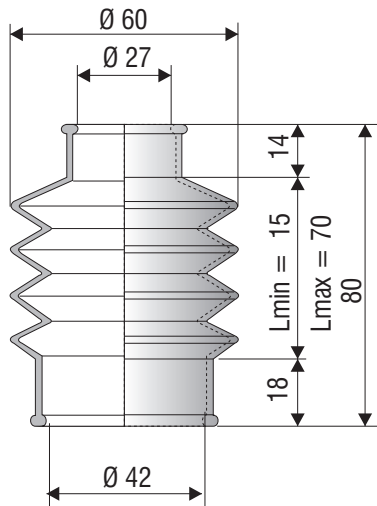

**F 1028 NBR**

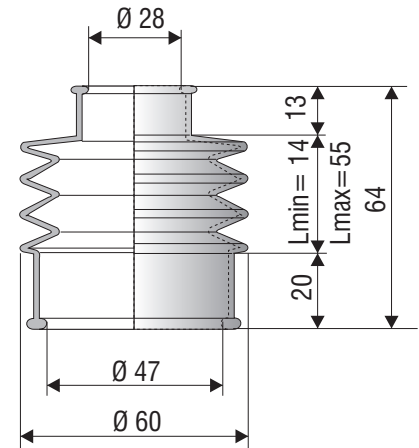

**F 1146 NBR**

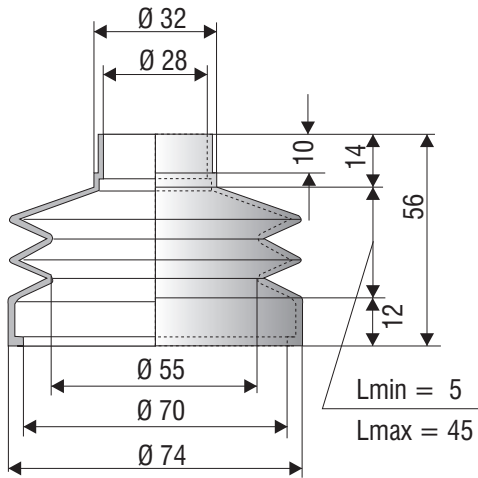

**F 900I Si**

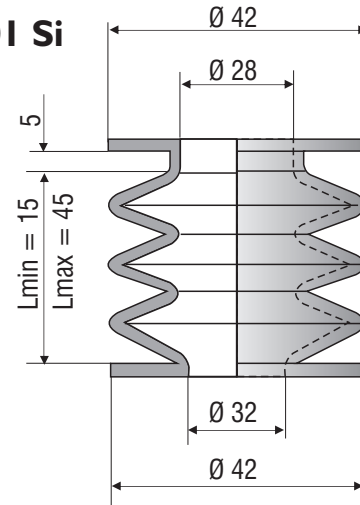

**F 1151 NBR**

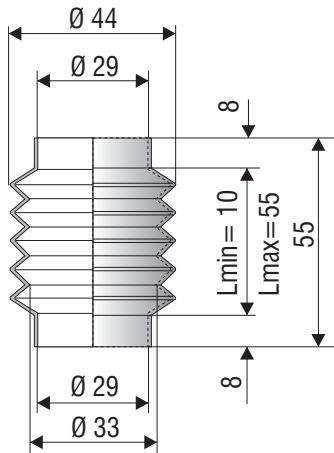

**F 1152 NBR**

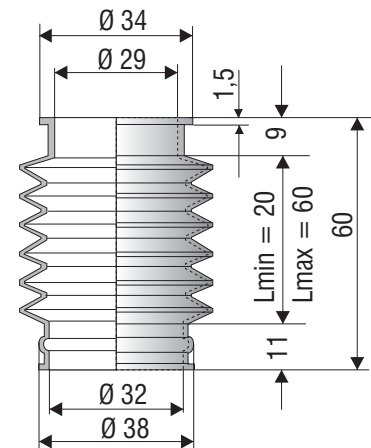



# Vulkanisierte Faltenbälge / Moulded Bellows

**Ø 29 - 30 mm**

**F 1095 NBR**

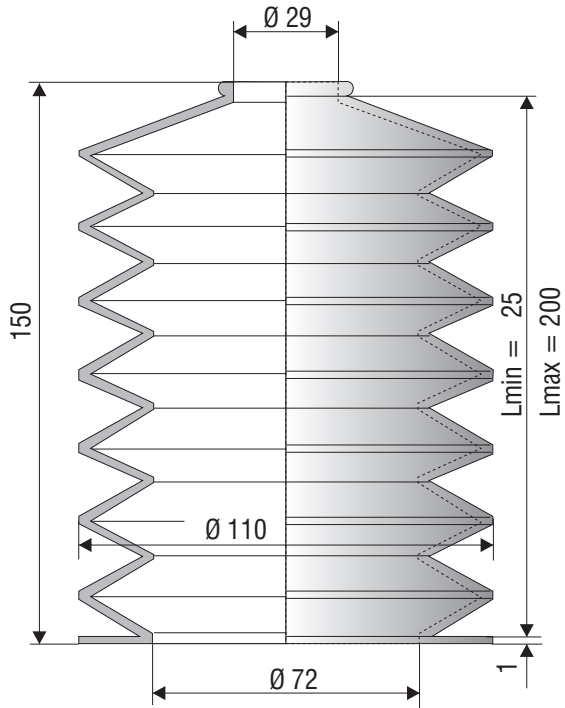

**F 1232 NBR**

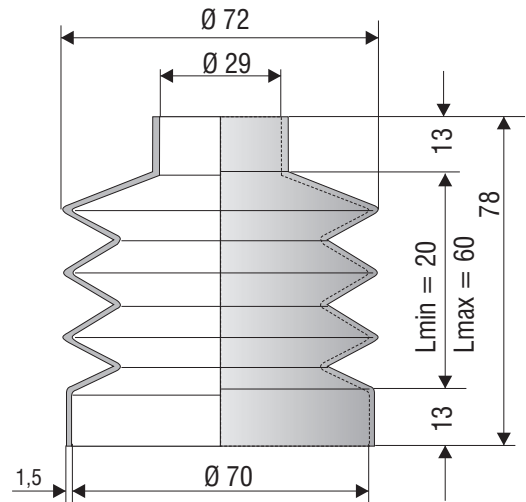

**F 1062 NBR**

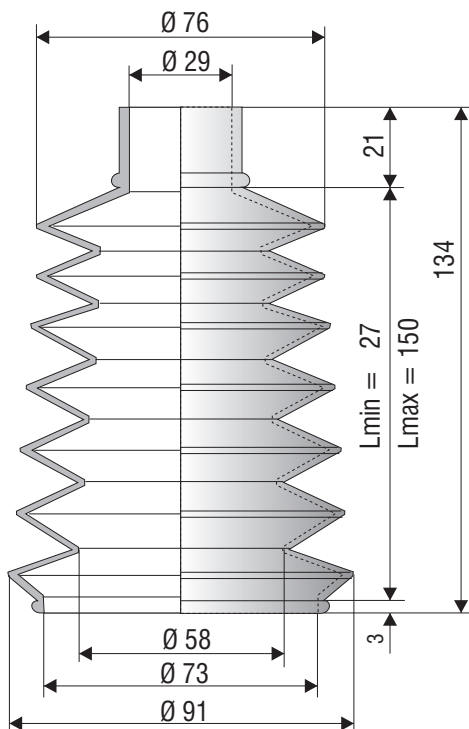

**F 1128 NBR**

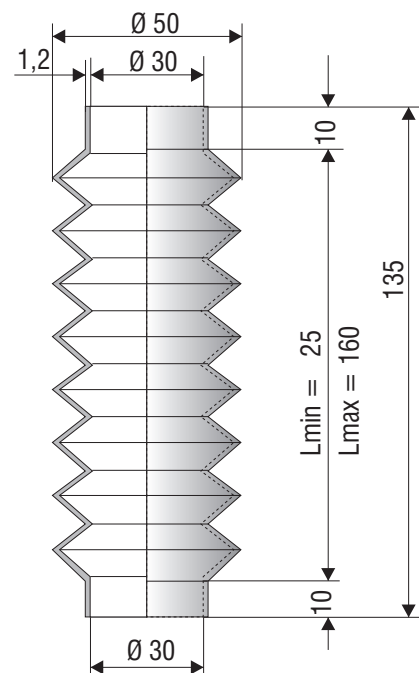



# Vulkanisierte Faltenbälge / Moulded Bellows

Ø 30 mm

**F 1073 NBR**

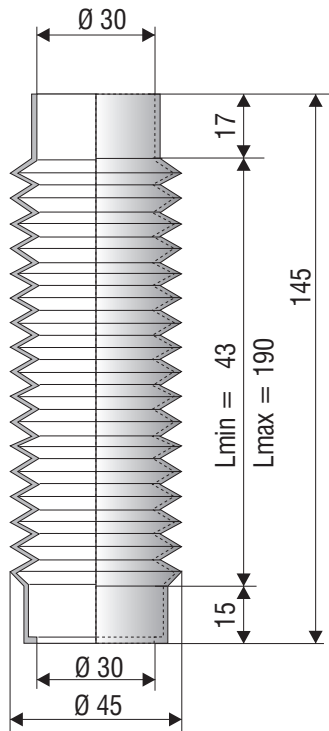

**F 1114 NBR**

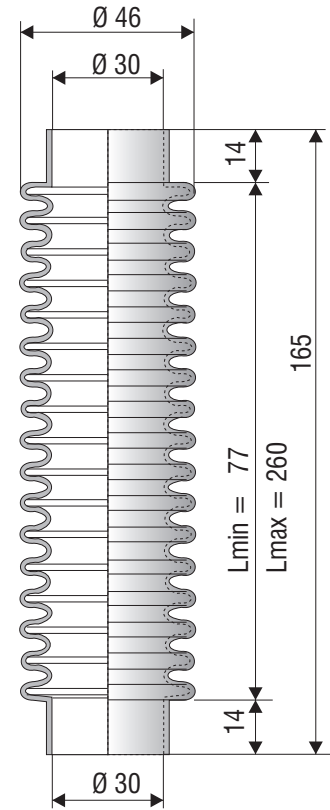

**F 1127 NBR**

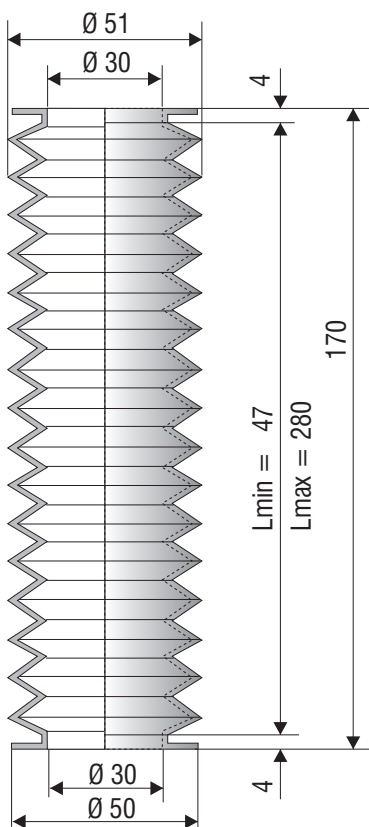

**F 1210 NBR**

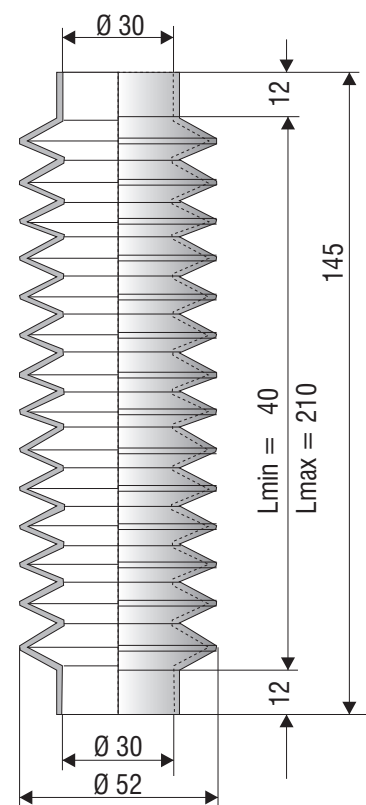





# Vulkanisierte Faltenbälge / Moulded Bellows

**Ø 29 - 30 mm**

**F 1238 NBR**

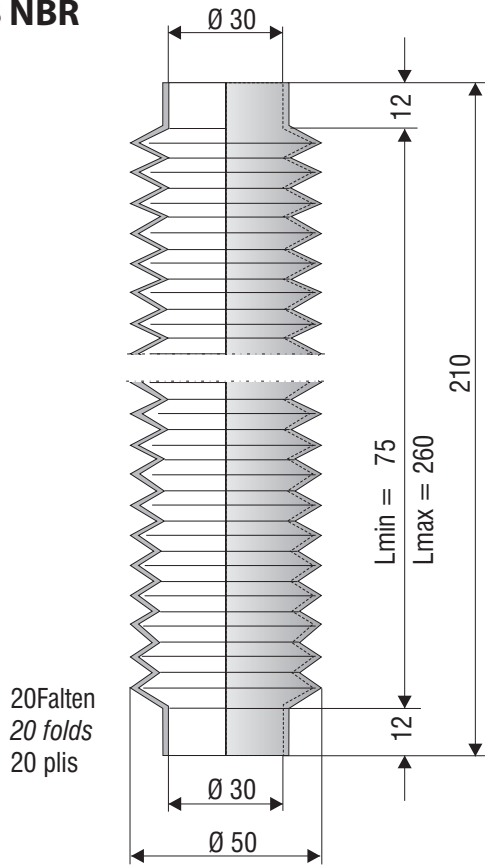

**F 1103 NBR**

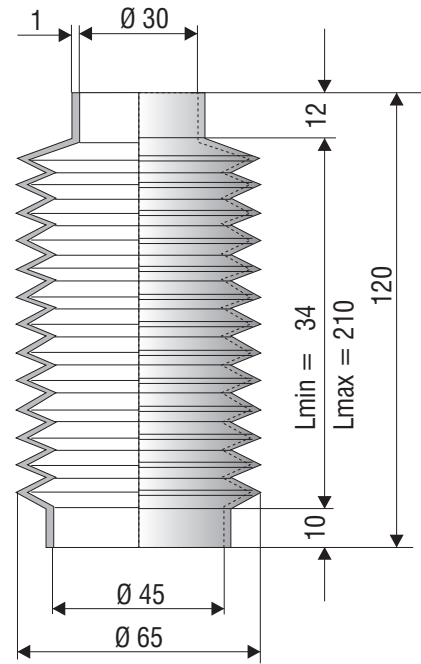

**F 4020 NBR**

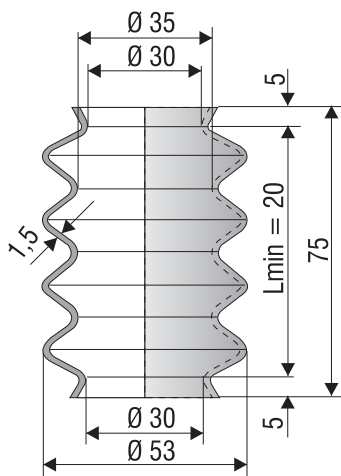

**F 4067 NBR**

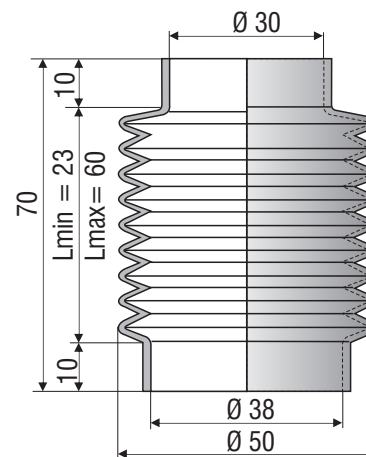



# Vulkanisierte Faltenbälge / Moulded Bellows

**Ø 30 - 32 mm**

**F 1057 NBR**

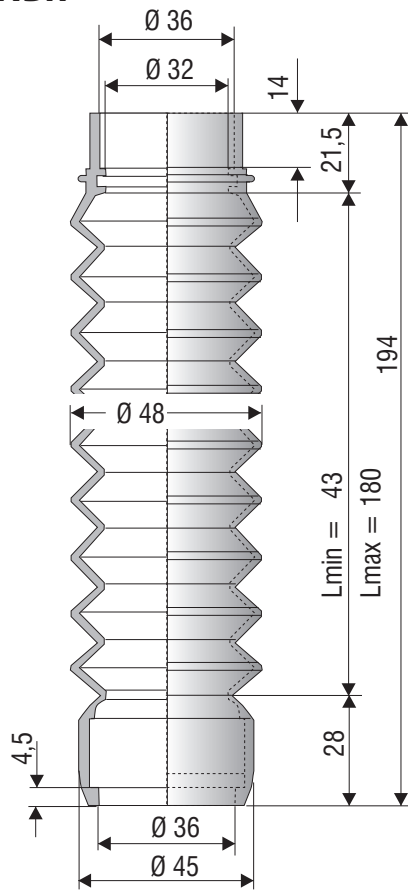

**F 1119 NBR**

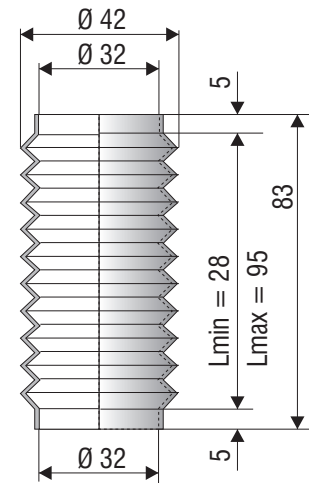

**F 1516 NBR**

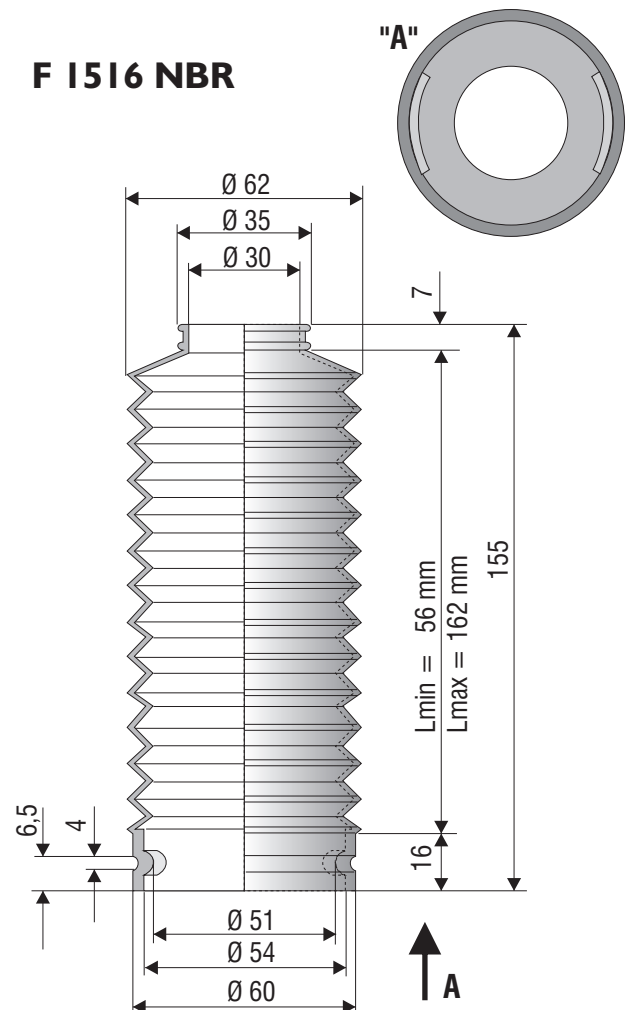



# Vulkanisierte Faltenbälge / Moulded Bellows

**Ø 32 - 33 mm**

**F 1058 NBR**

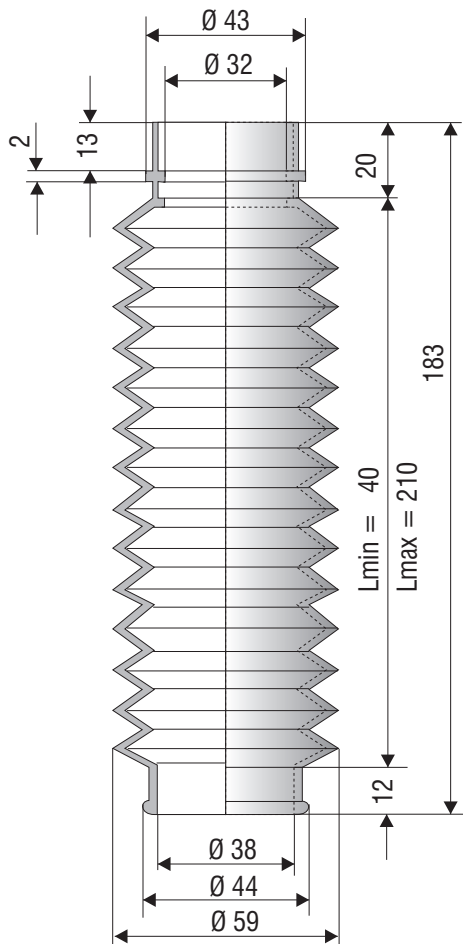

**F 1115 NBR**

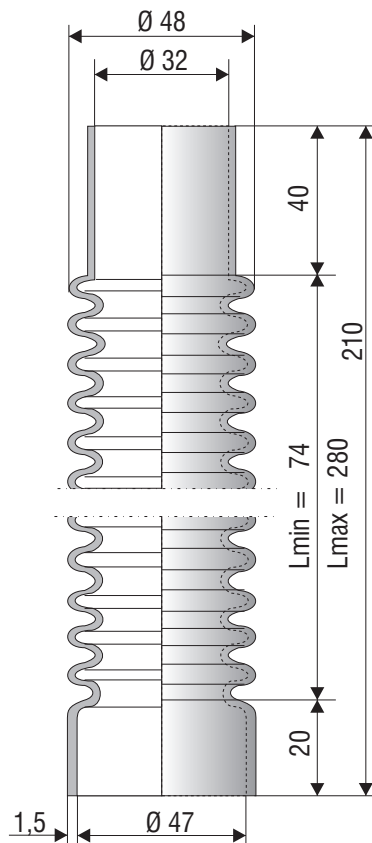

**F 1206 NBR**

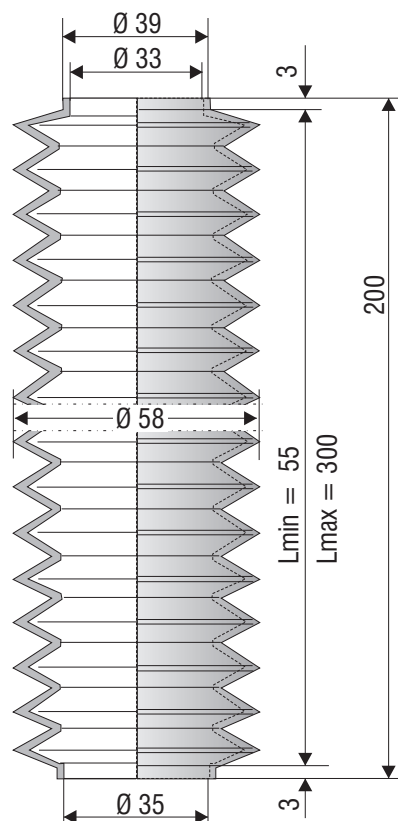

**F 1099 NBR**

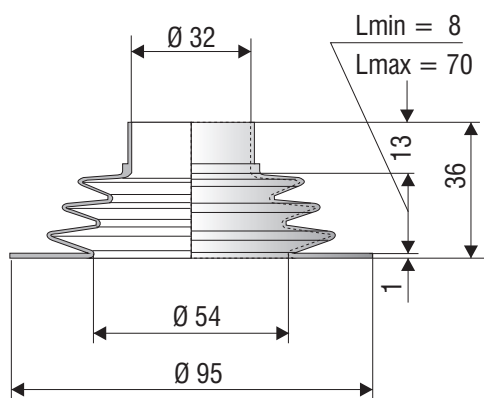



# Vulkanisierte Faltenbälge / Moulded Bellows

**Ø 33 - 35 mm**

**F 1075 NBR**

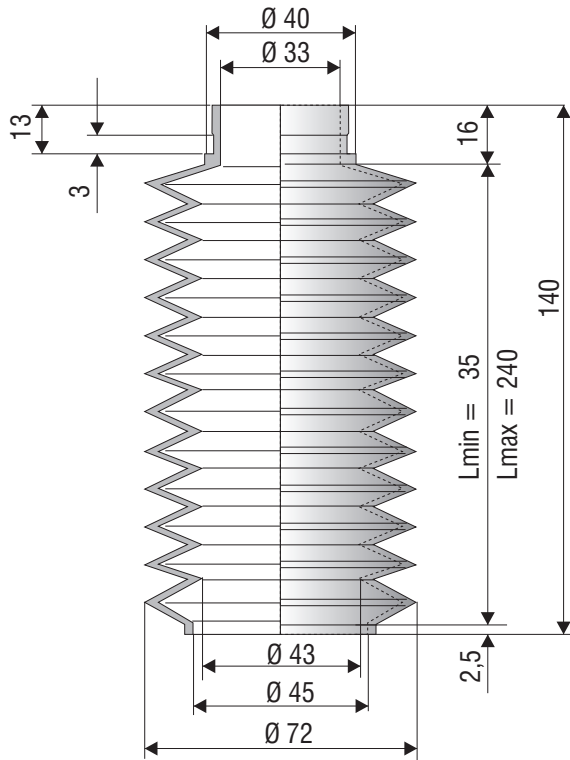

**F 1072 NBR**

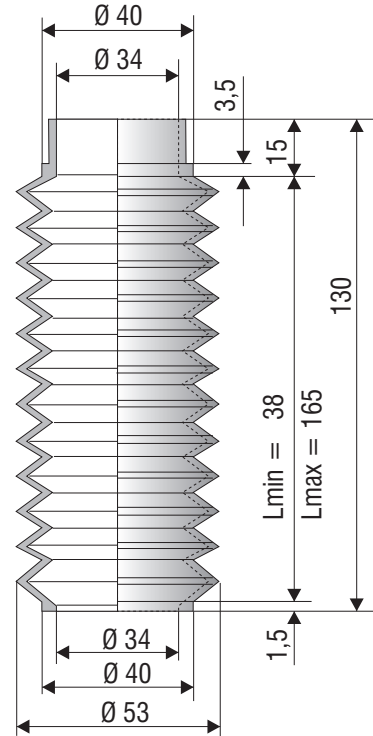

**F 1087 NR**

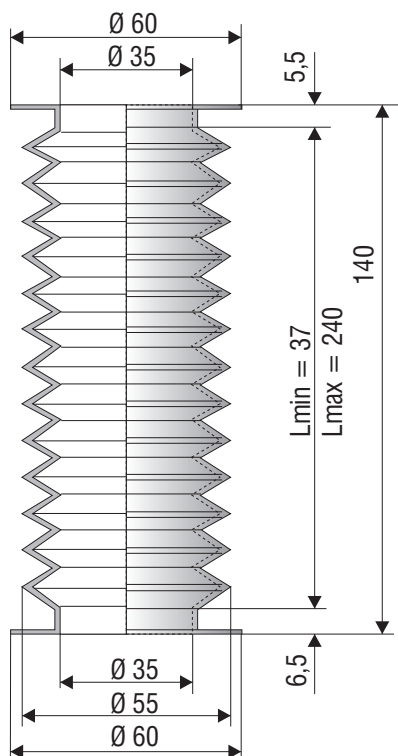

**F 1209 NBR**

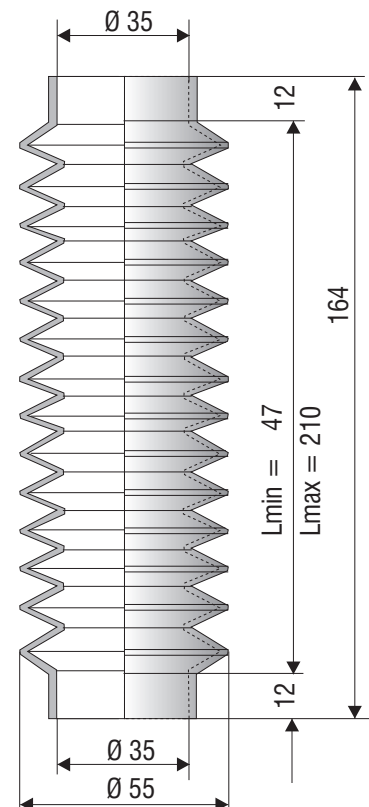



# Vulkanisierte Faltenbälge / Moulded Bellows

**Ø 35 mm**

**F 1020 NBR**

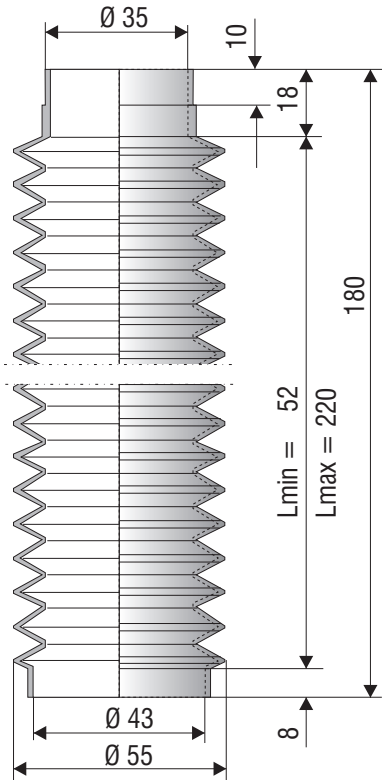

**F 1158 NBR**

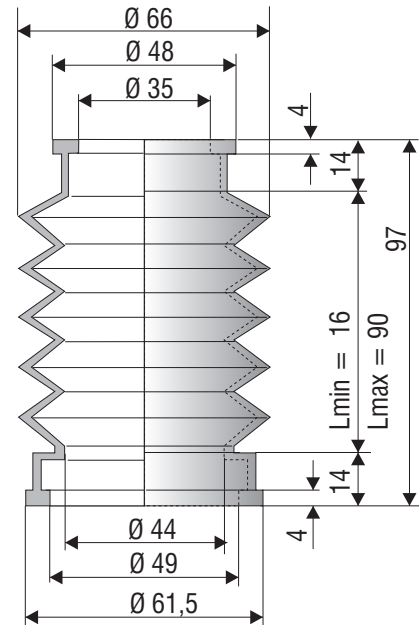

**F 1249 NBR**

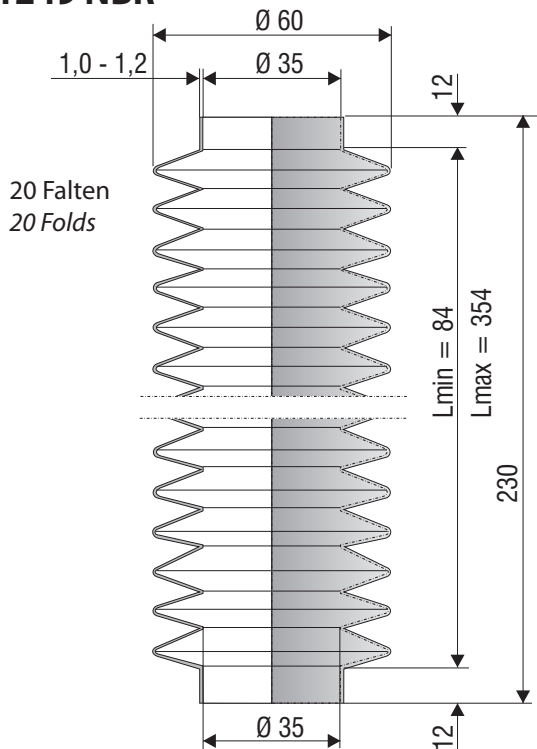

**F 4018 NBR**

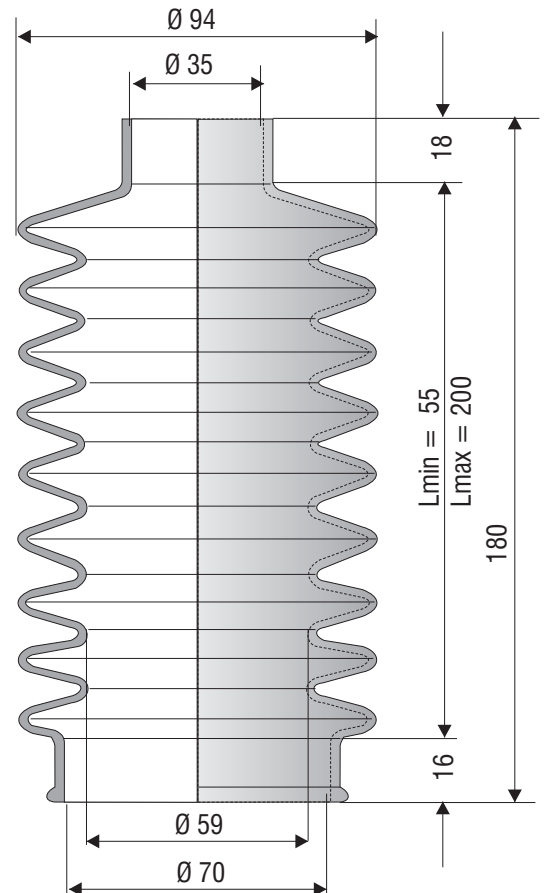



# Vulkanisierte Faltenbälge / Moulded Bellows

## Ø 35 - 36 mm

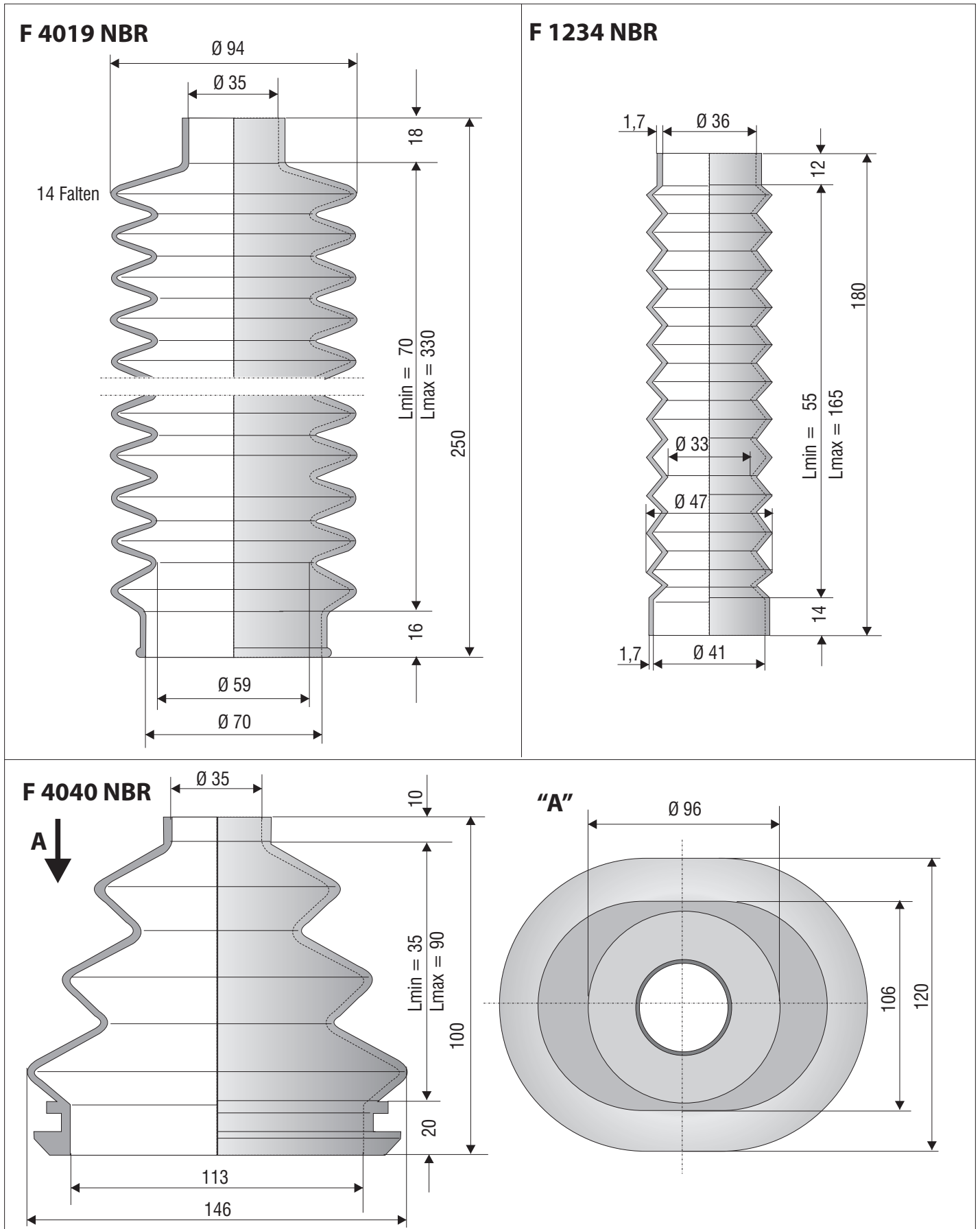



# Vulkanisierte Faltenbälge / Moulded Bellows

**Ø 36 - 37 mm**

**F 1521 NBR**

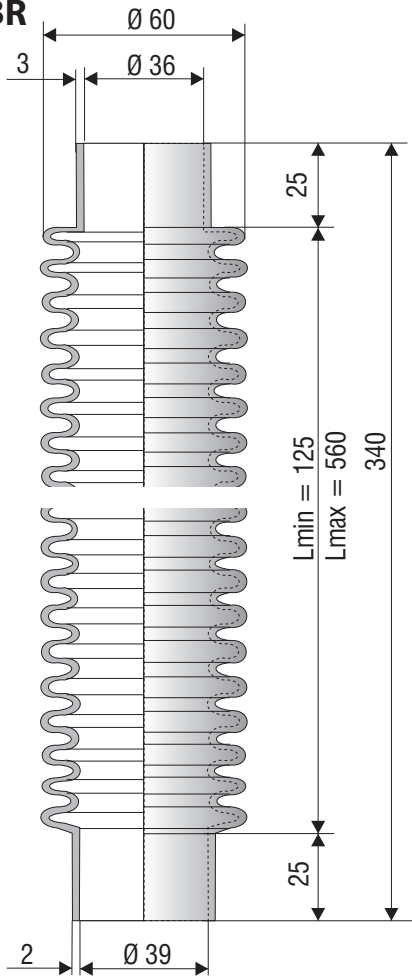

**F 4017 NBR**

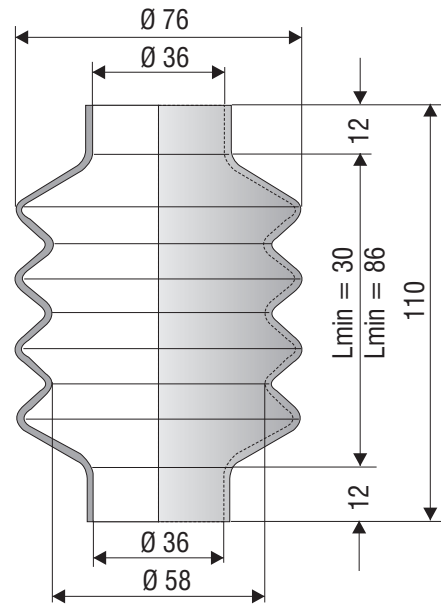

**F 1026 NBR**

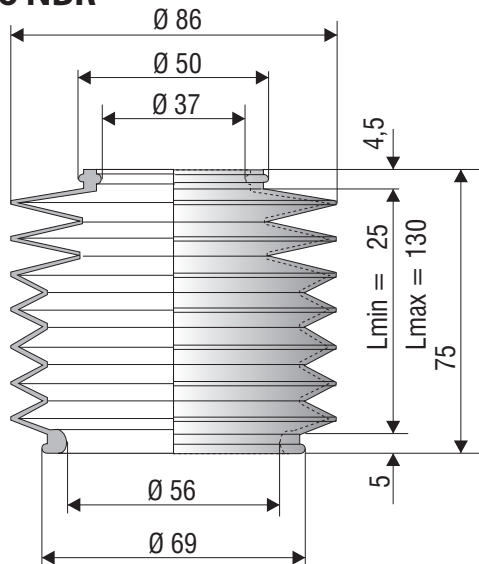

**F 1036 NBR**

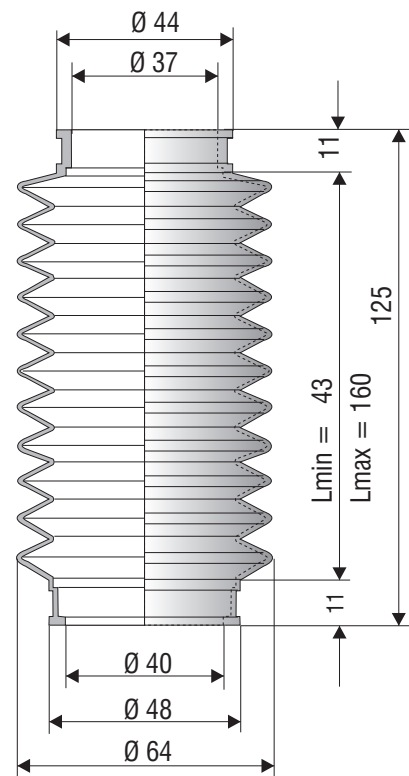



# Vulkanisierte Faltenbälge / Moulded Bellows

Ø 38 mm

**F 1214 NBR**

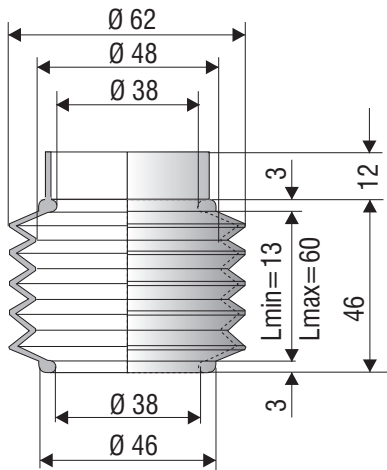

**F 1176 NBR**  
**F 1176 Si**

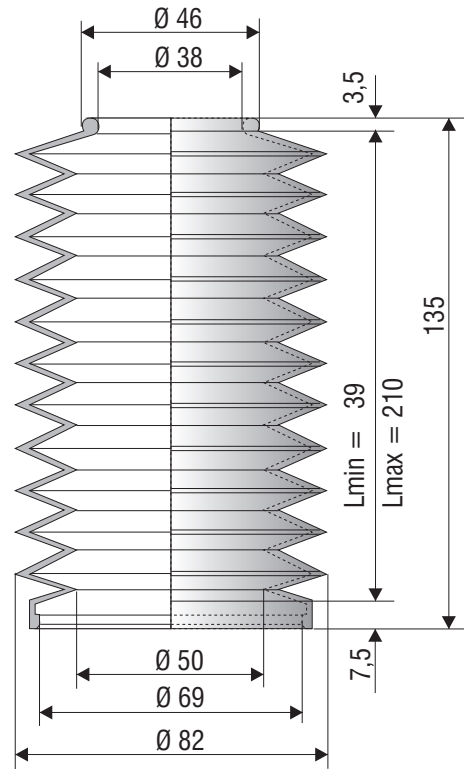

**F 4066 NBR**

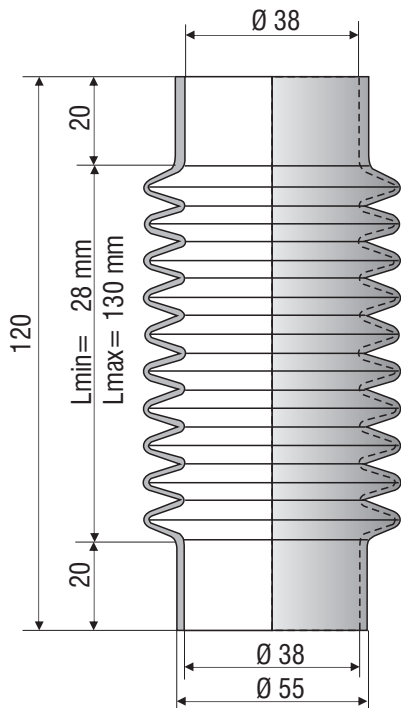

**F 4015 NBR**

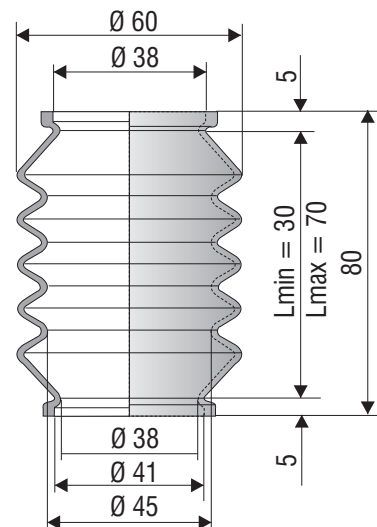





# Vulkanisierte Faltenbälge / Moulded Bellows

**Ø 38 - 39 mm**

**F 4016 NBR**

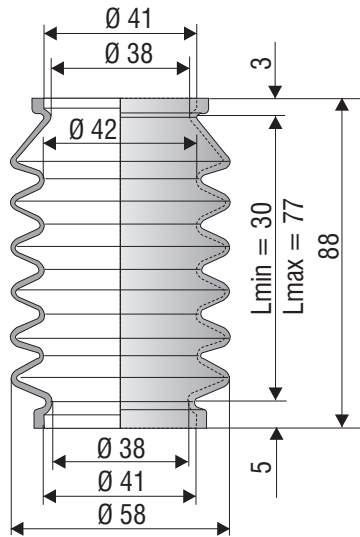

**F 1231 NBR**

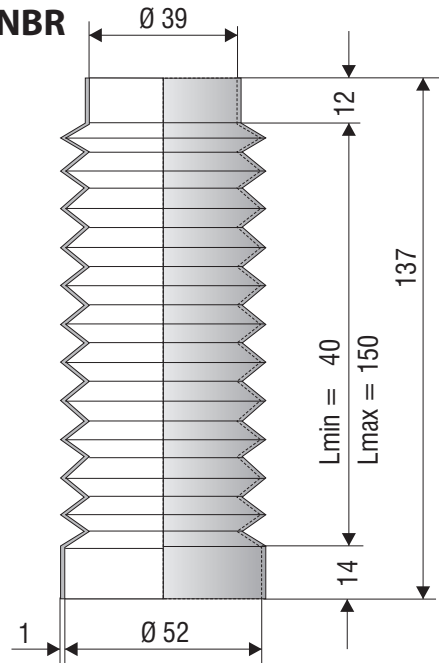

**F 3012 NBR**

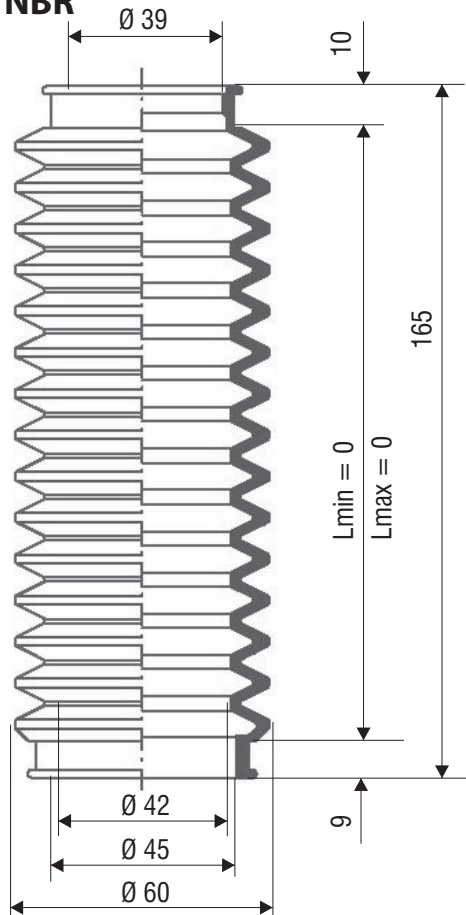

**F 3010 NBR**

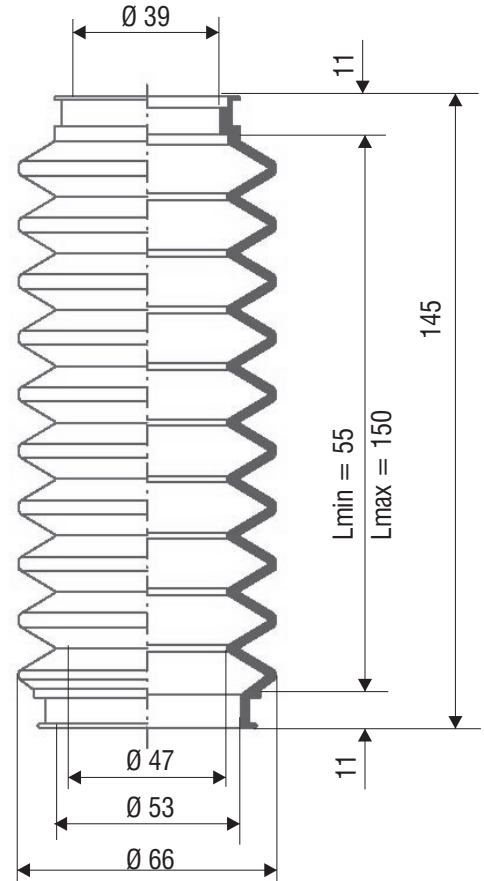



# Vulkanisierte Faltenbälge / Moulded Bellows

Ø 39 - 40 mm

**F 1014 NBR**

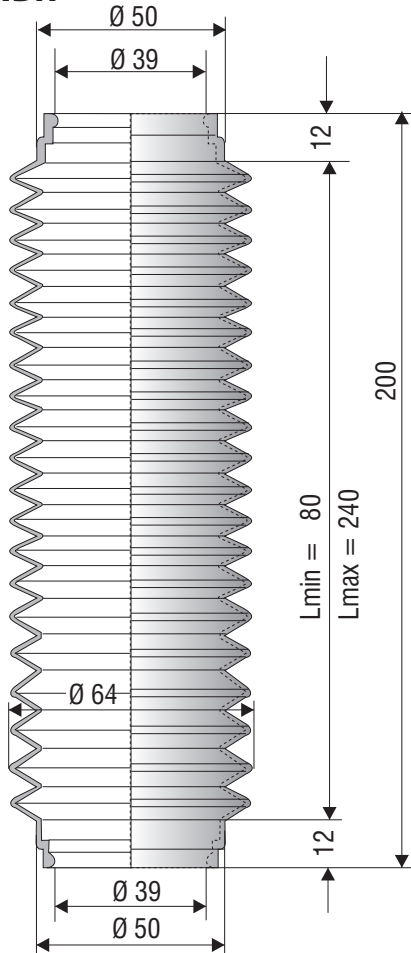

**F 4061 NBR**

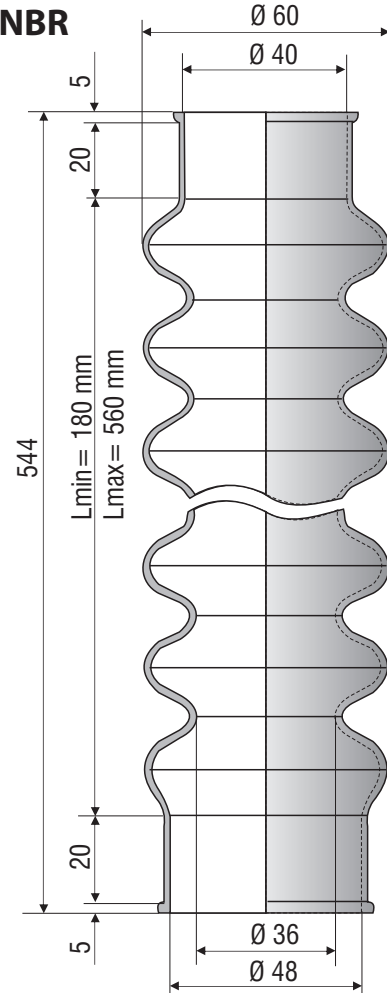

**F 4014 NBR**

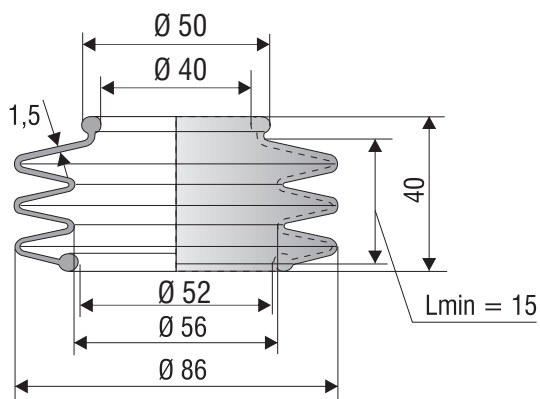

**F 1040 NBR**

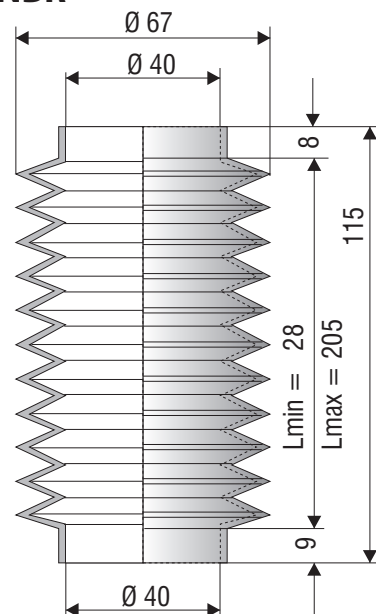



# Vulkanisierte Faltenbälge / Moulded Bellows

Ø 40 mm

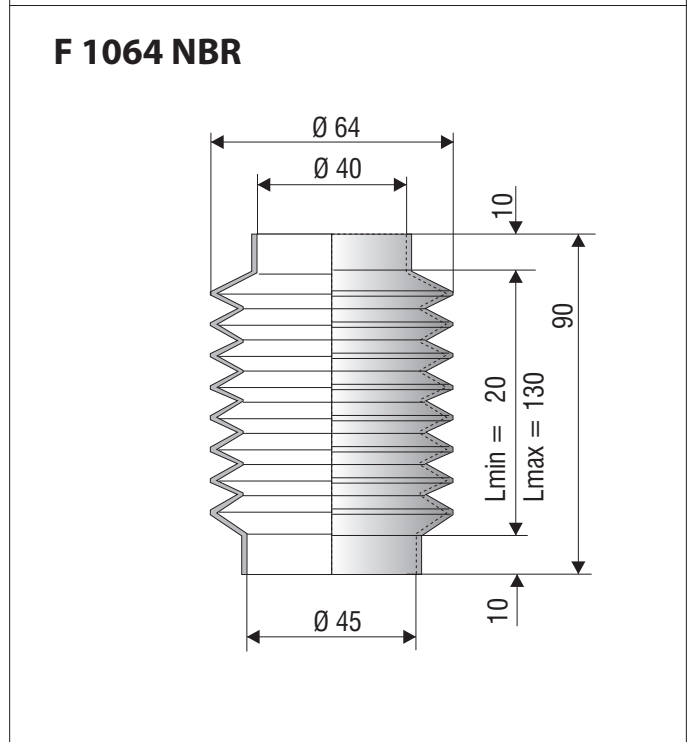
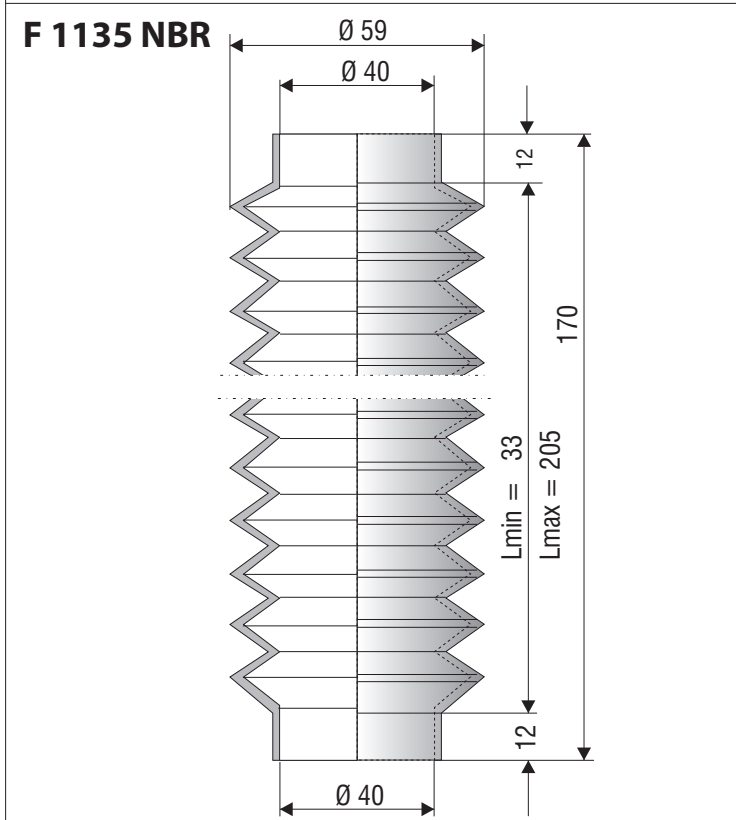
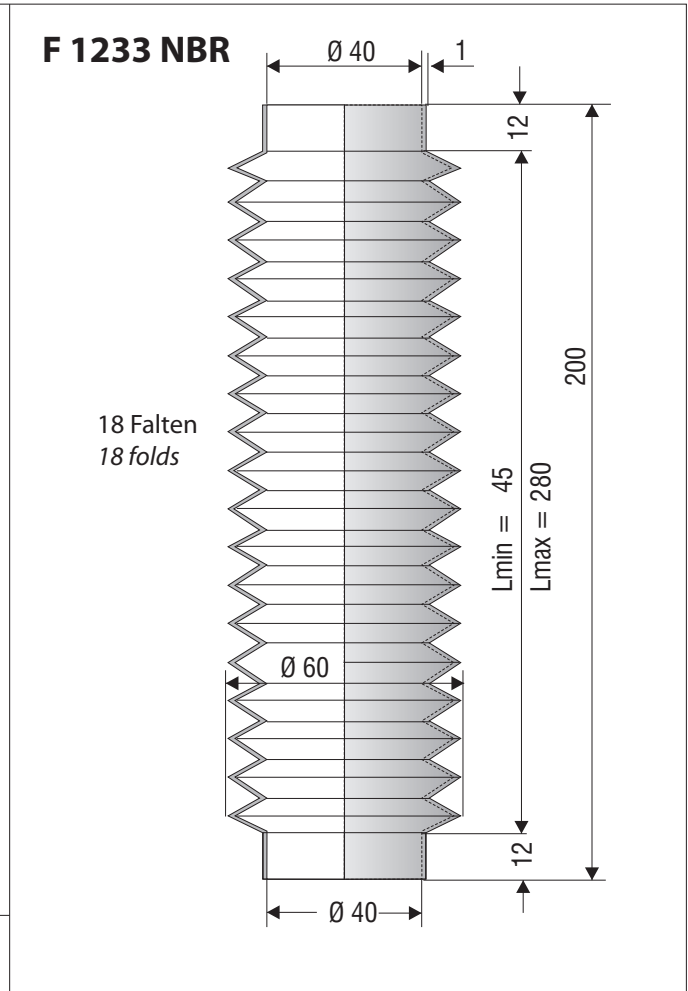
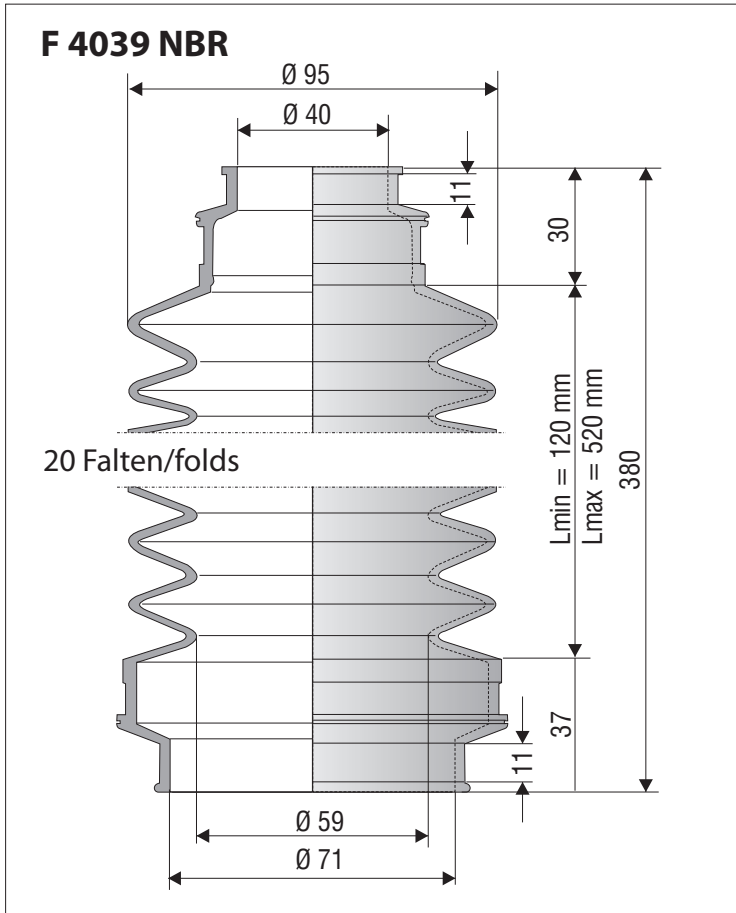



# Vulkanisierte Faltenbälge / Moulded Bellows

**Ø 40 - 41 mm**

**F 1002 NBR**

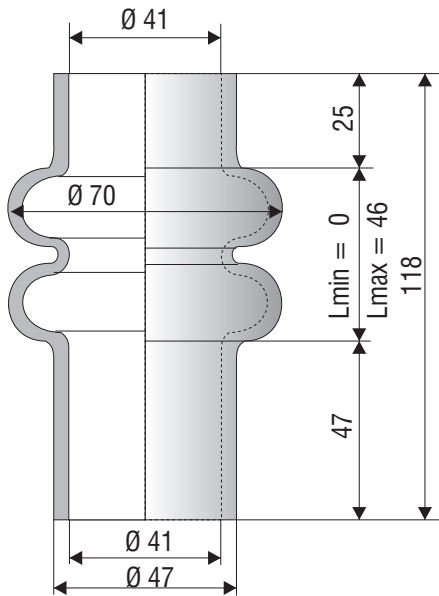

**F 1157 NBR**

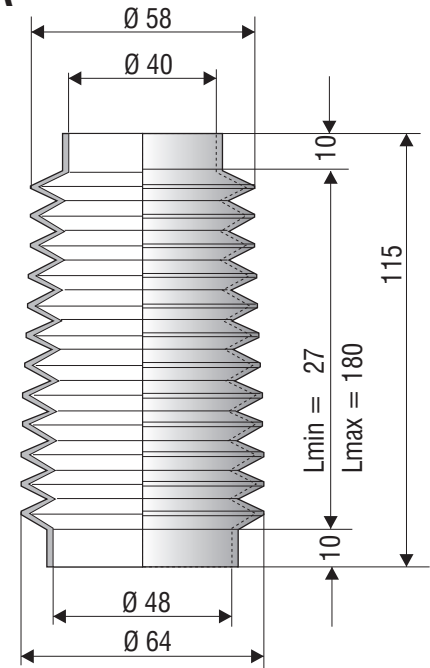

**F 1005 NBR**

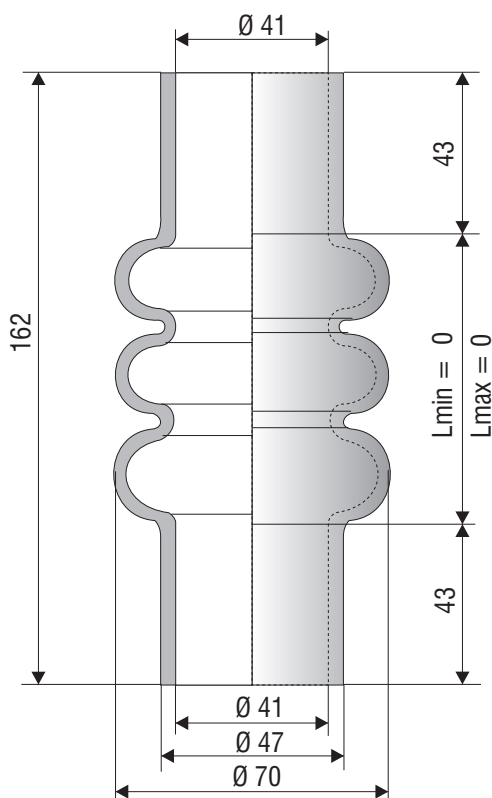

**F 1105 CR**

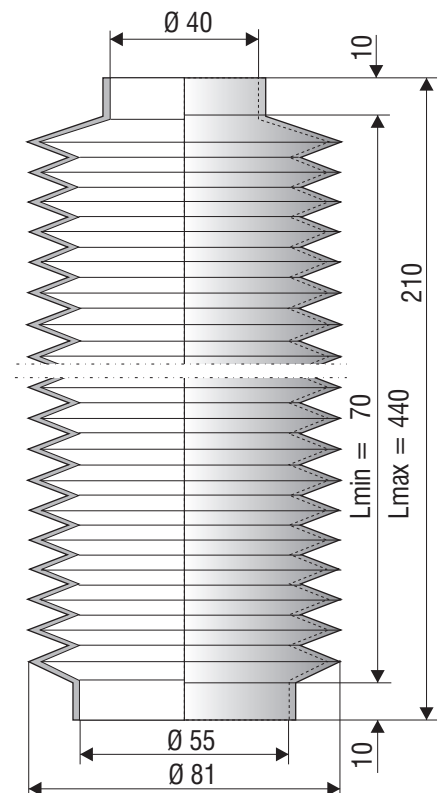



# Vulkanisierte Faltenbälge / Moulded Bellows

**Ø 43 - 45 mm**

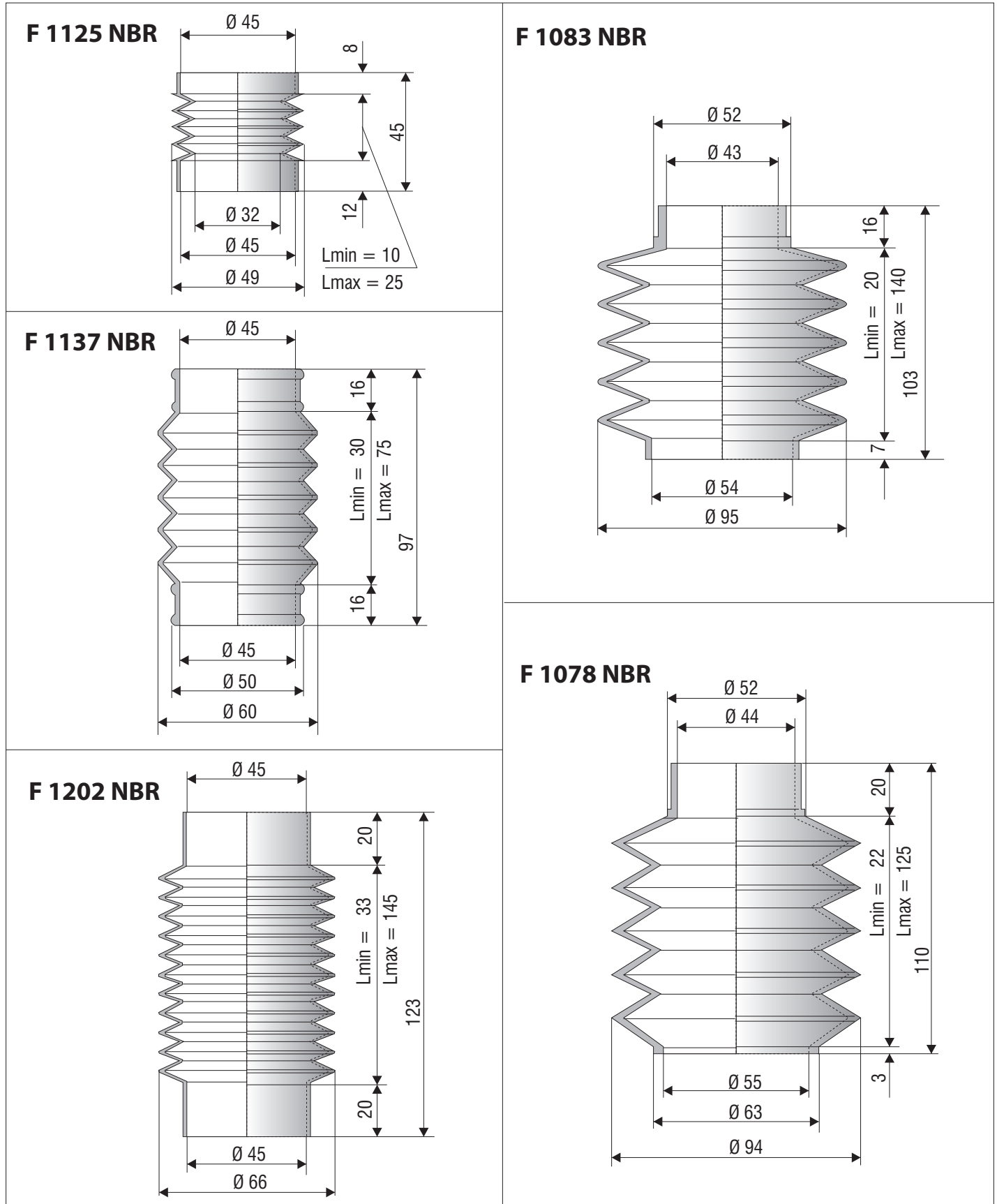



# Vulkanisierte Faltenbälge / Moulded Bellows

Ø 45 mm

## F 4069 NBR

10 Falten

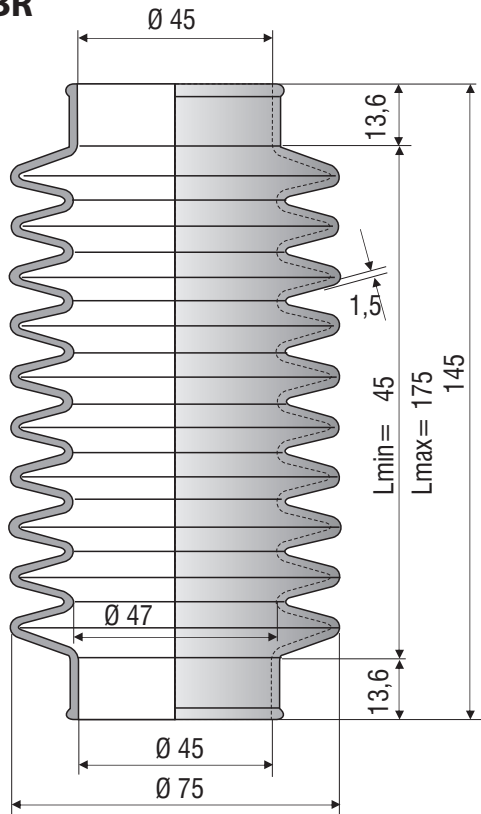

## F 1223 NBR

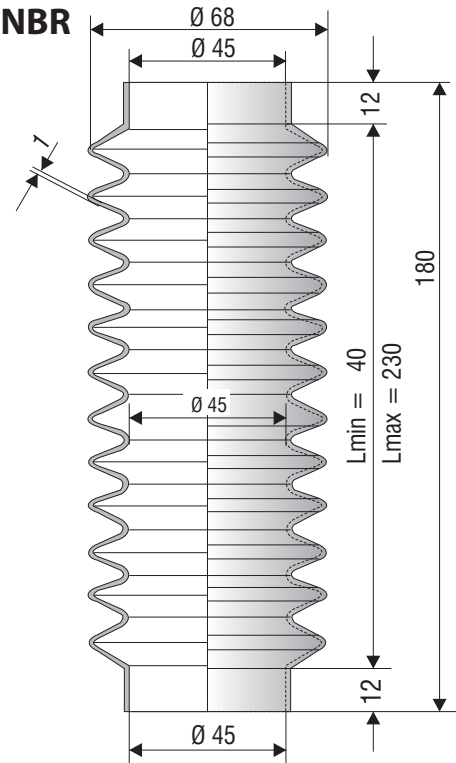

## F 9003 NBR

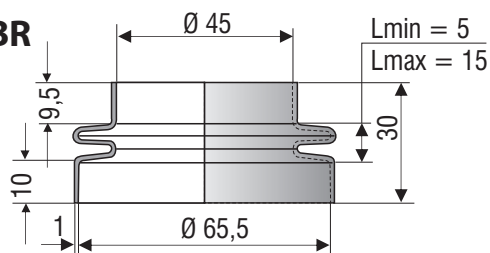

## F 1229 NBR

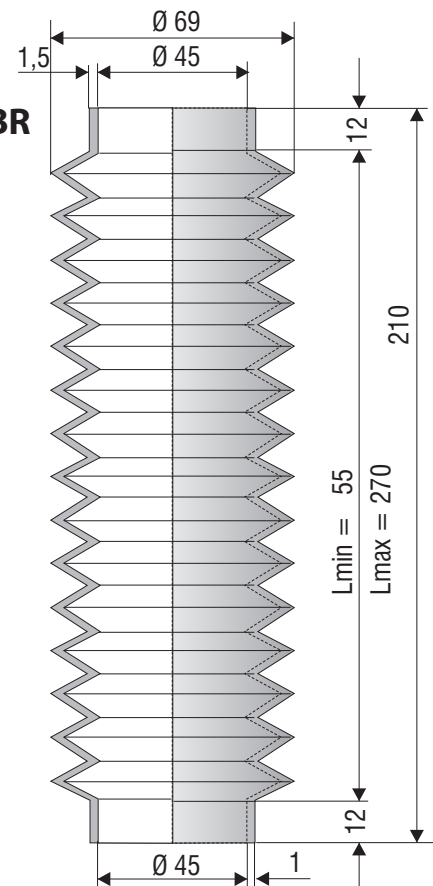

## F 4038 NBR

Sehr stabiler Balg.  
Very sturdy  
bellows.

Verstärkungsring  
Reinforcement ring

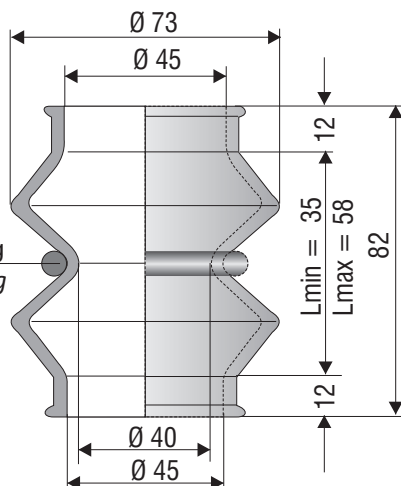



# Vulkanisierte Faltenbälge / Moulded Bellows

**Ø 45 - 47 mm**

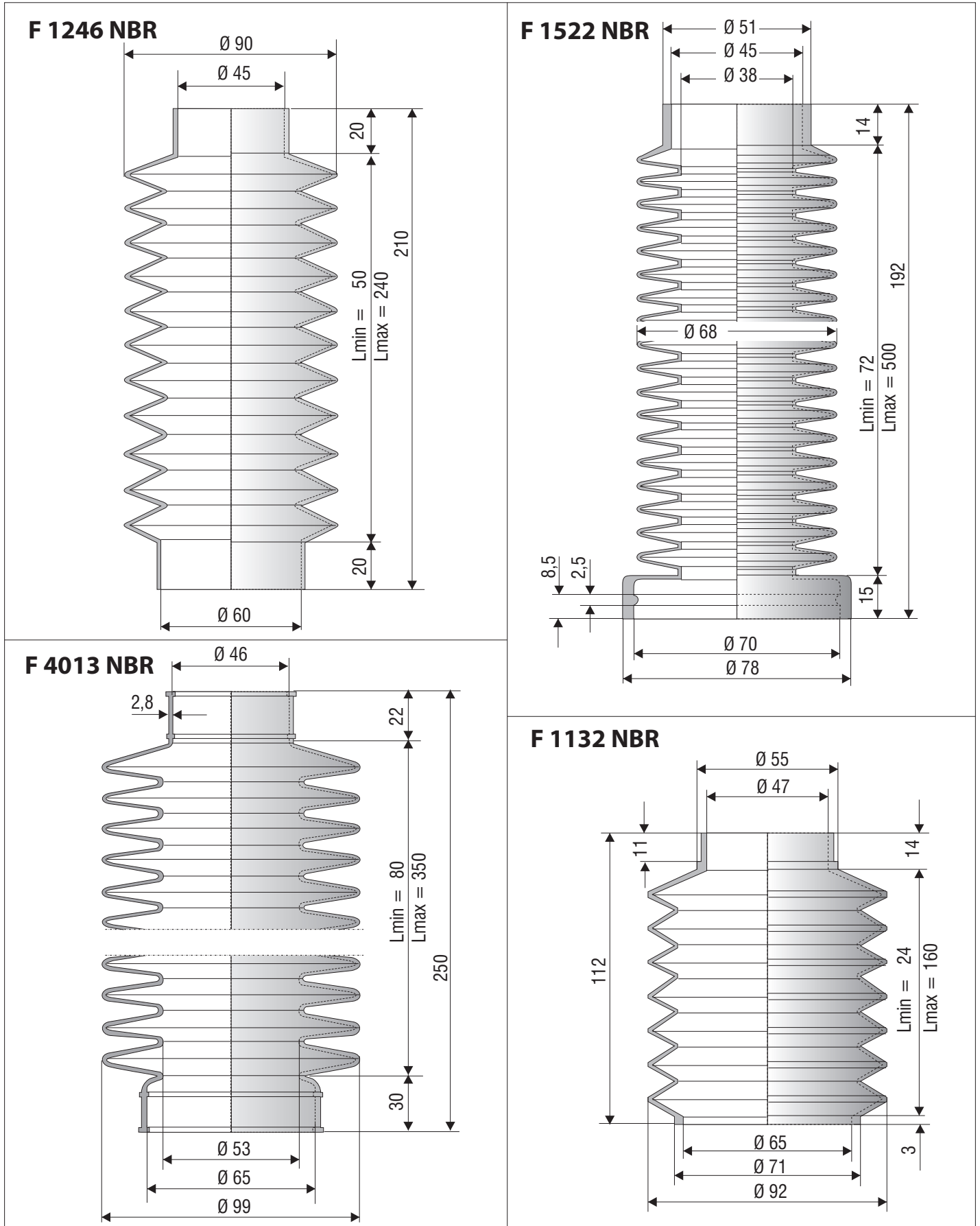



# Vulkanisierte Faltenbälge / Moulded Bellows

**Ø 46 - 48 mm**

**F 1188 NBR**

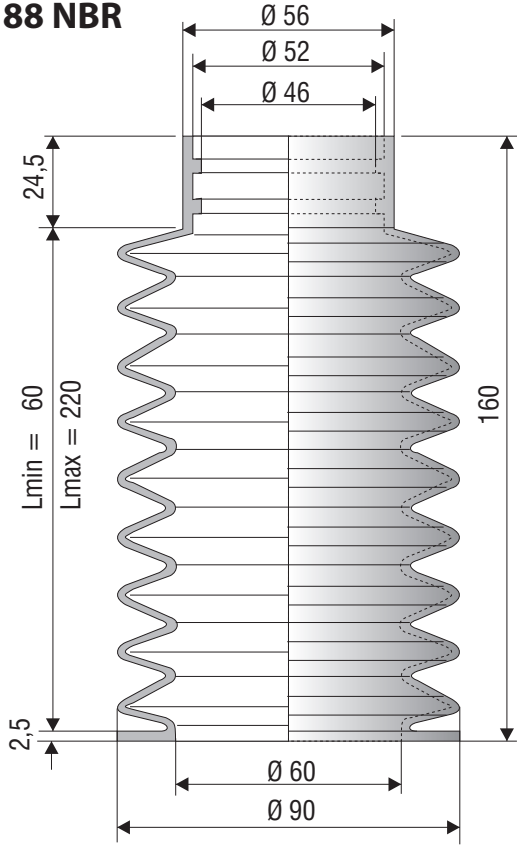

**F 1123 NBR**

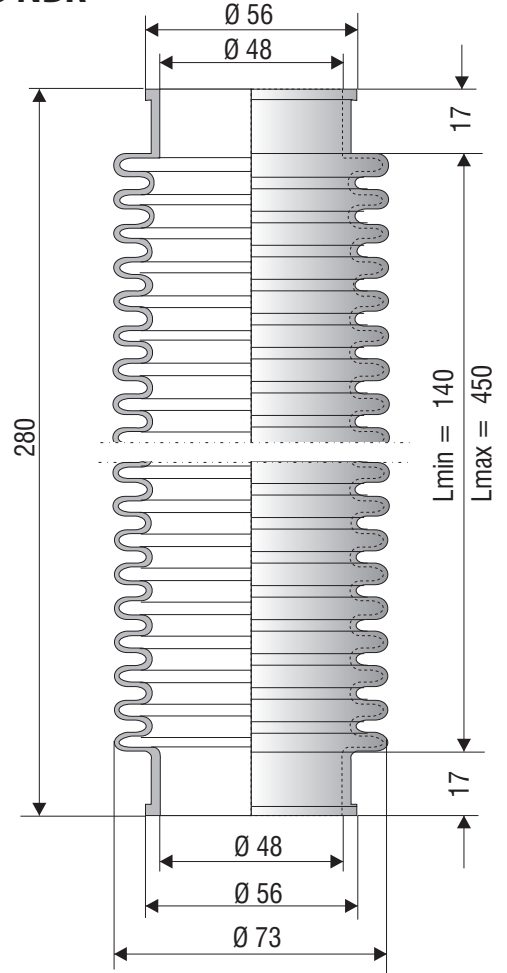

**F 1030 NBR**

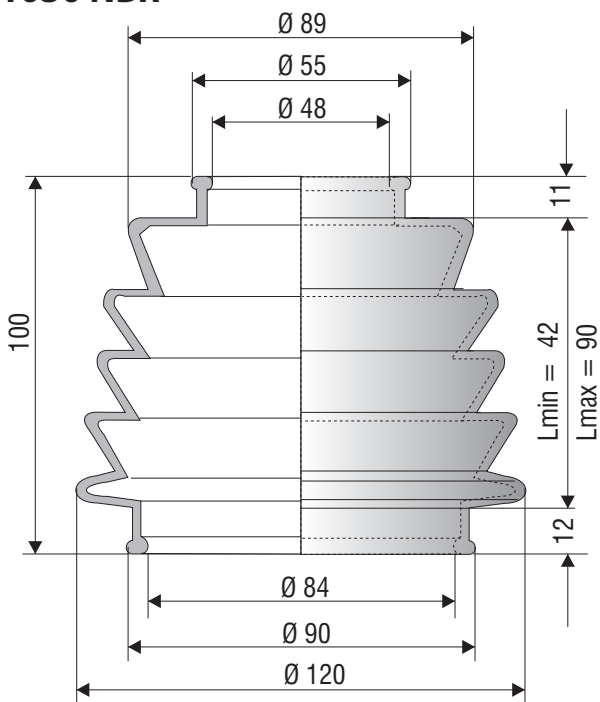

**F 1025 NBR**

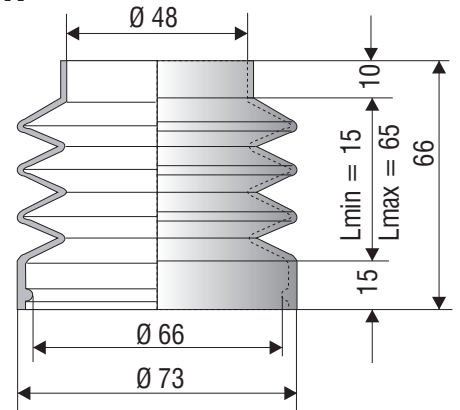





# Vulkanisierte Faltenbälge / Moulded Bellows

**Ø 49 - 50 mm**

**F 1173 NBR**

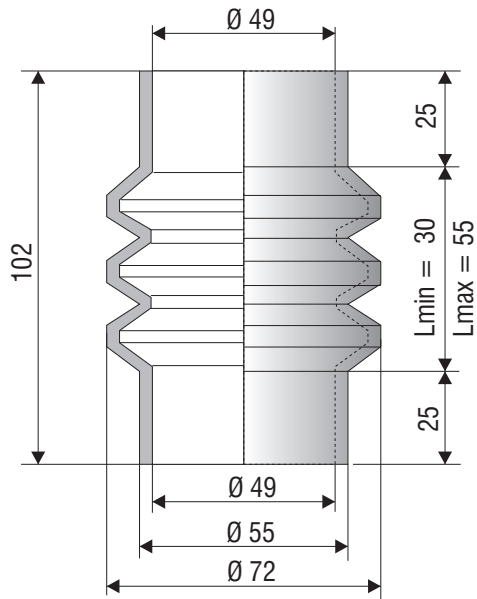

**F 1126 NBR**

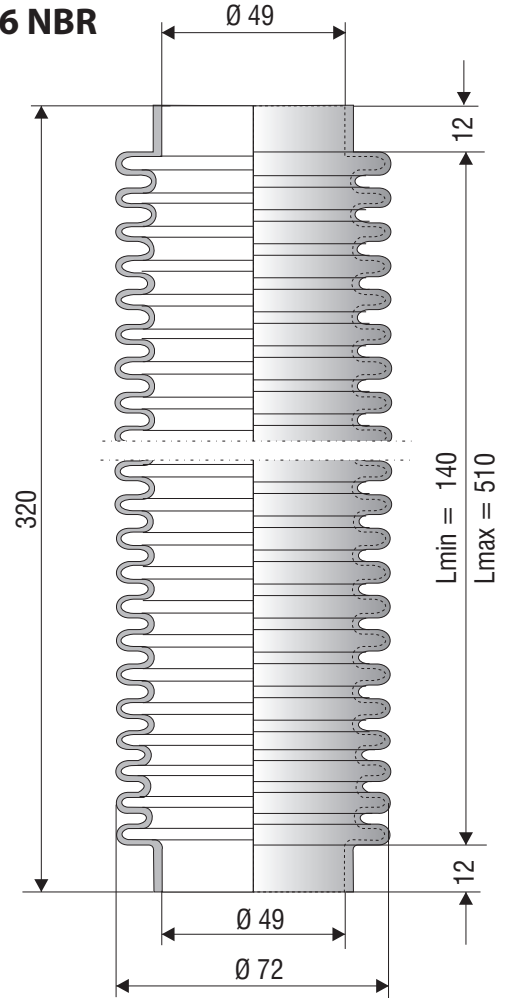

**F 1205 NBR**

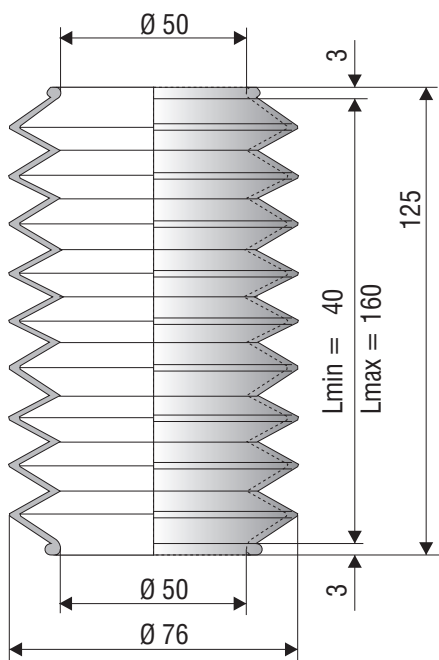

**F 1160 NBR**

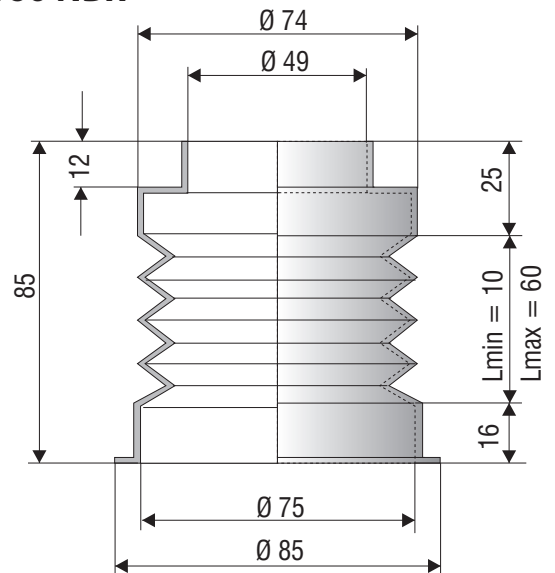



# Vulkanisierte Faltenbälge / Moulded Bellows

Ø 50 mm

**F 1112 NBR**

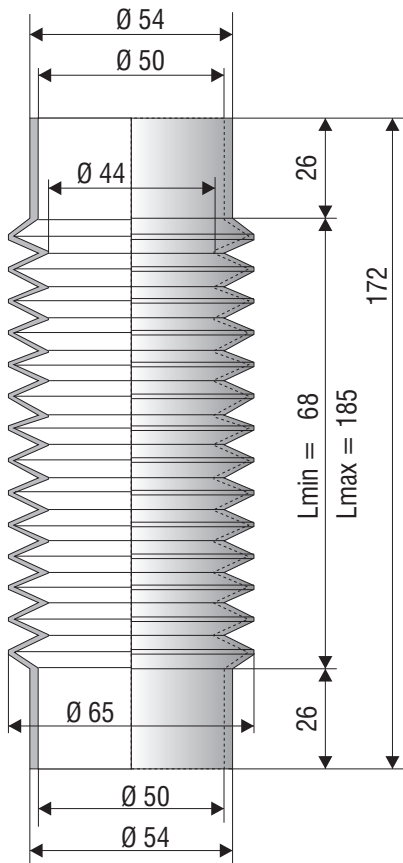

**F 1141 NBR**

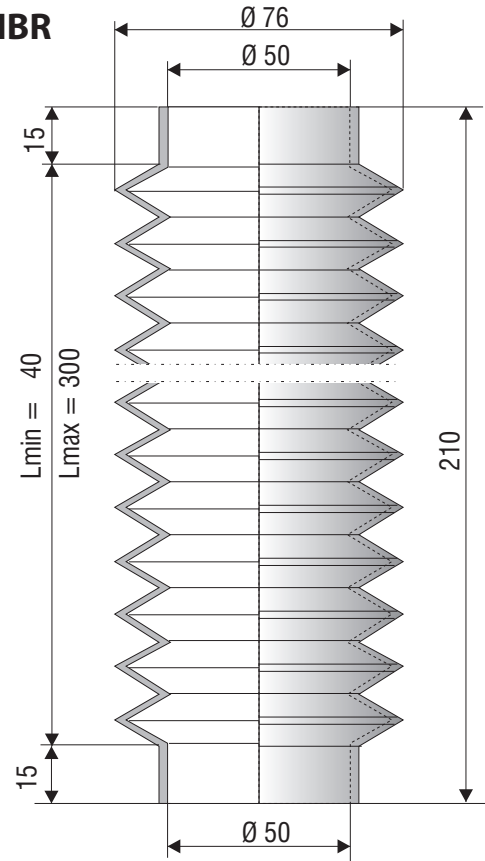

**F 1208 NBR**

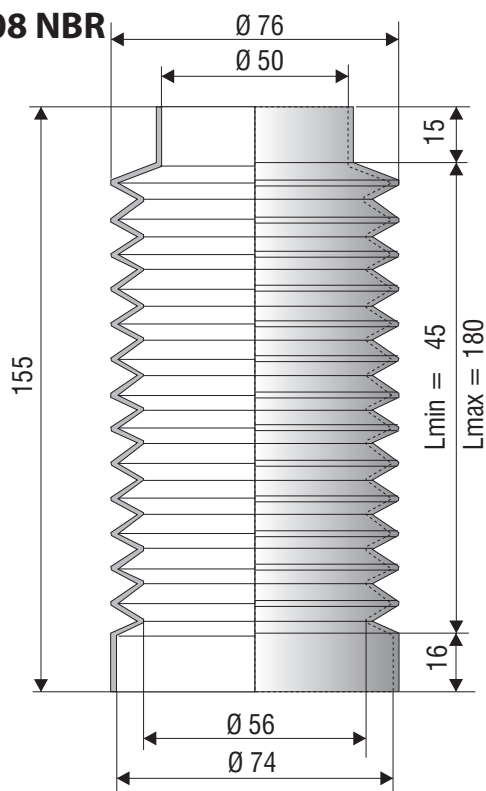

**F 1055 NBR**

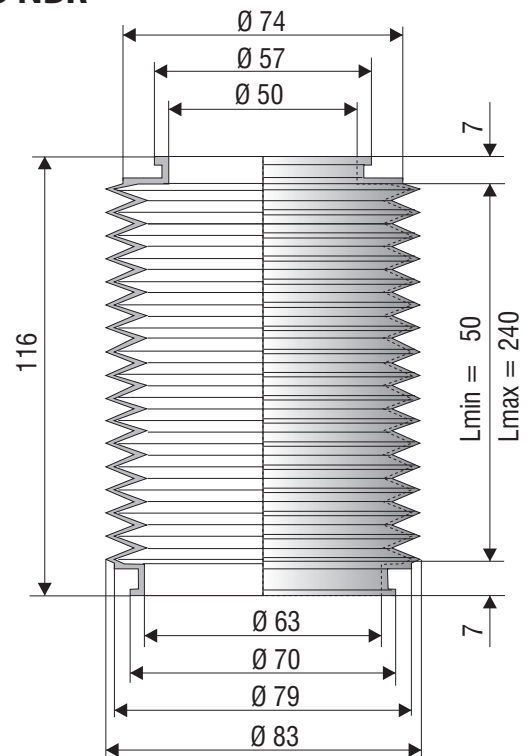



# Vulkanisierte Faltenbälge / Moulded Bellows

**Ø 50 - 51 mm**

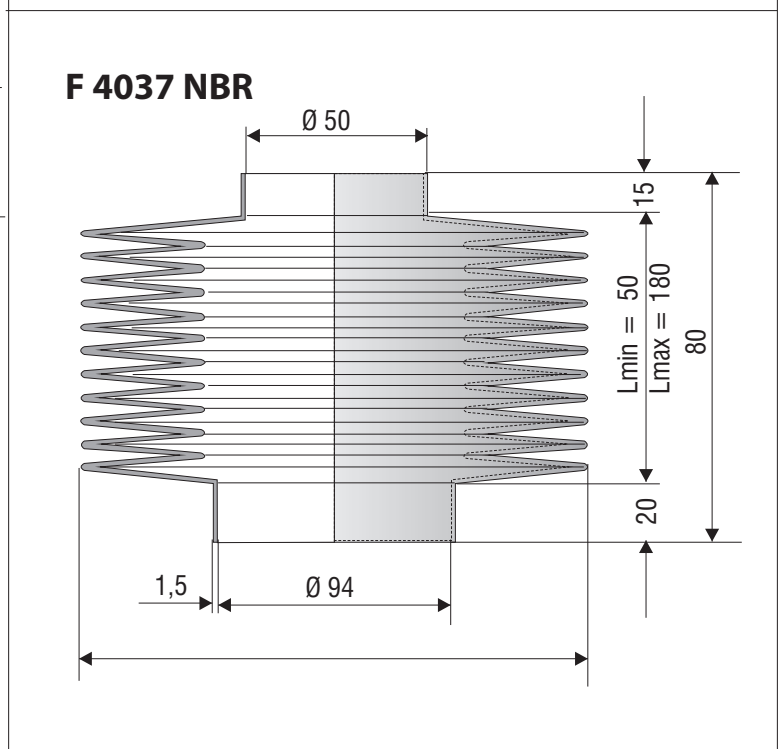
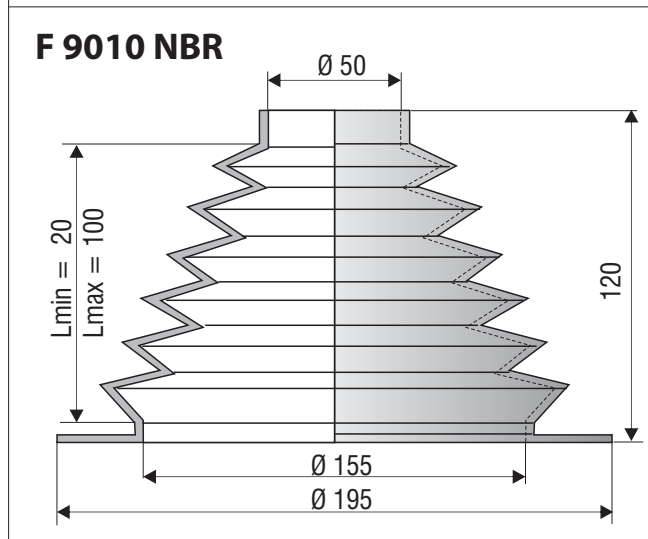
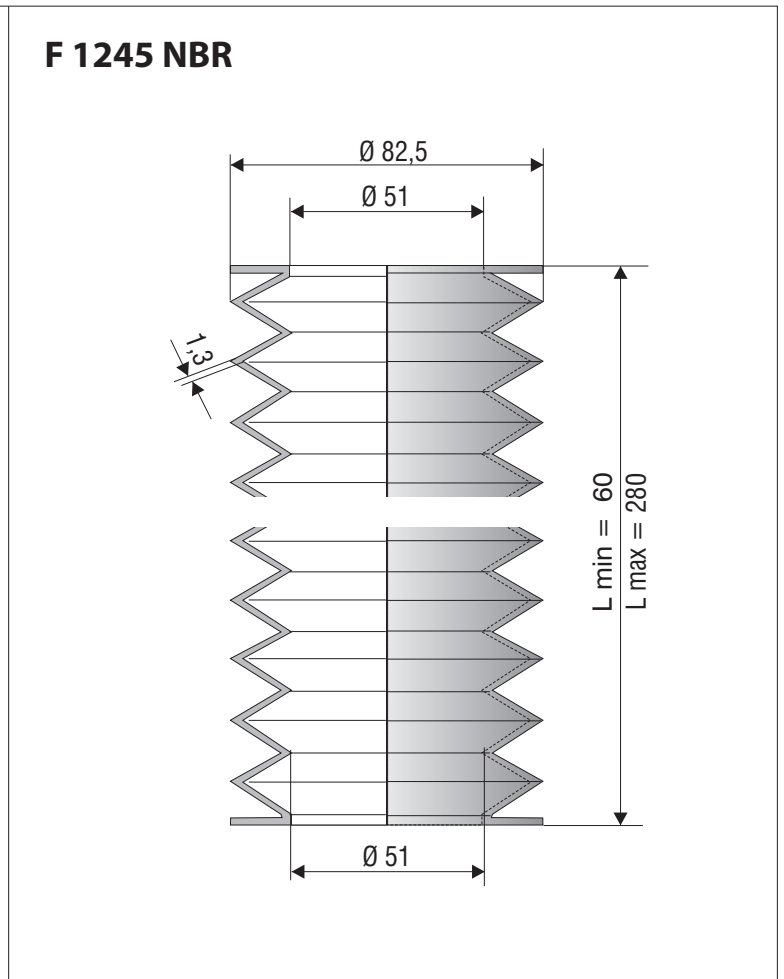
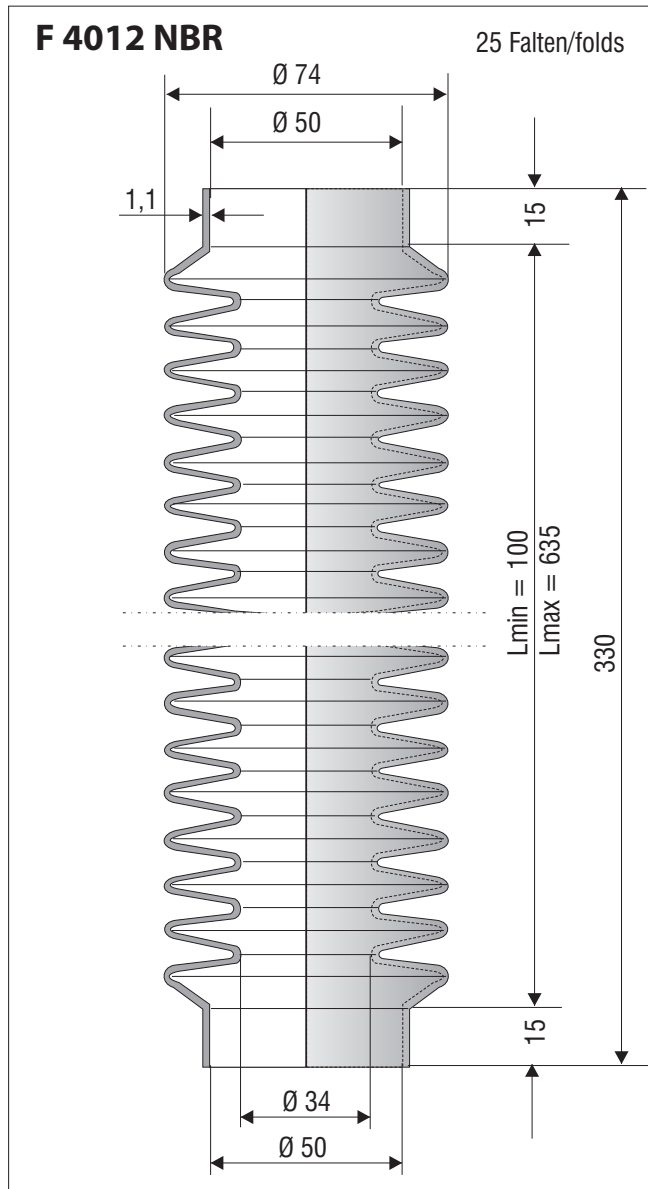



# Vulkanisierte Faltenbälge / Moulded Bellows

**Ø 52 - 54 mm**

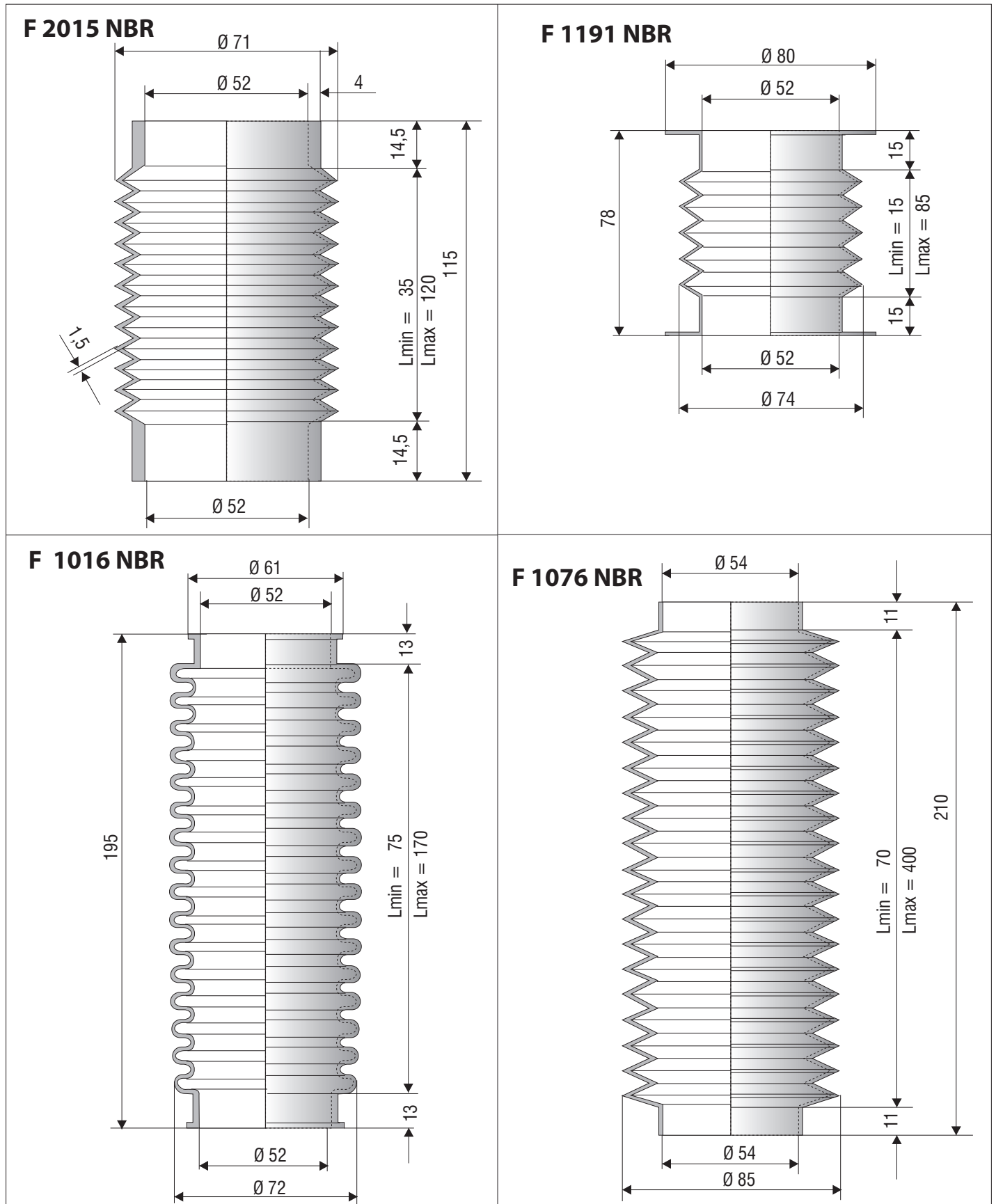



# Vulkanisierte Faltenbälge / Moulded Bellows

**Ø 53 - 55 mm**

**F 4011 NBR**

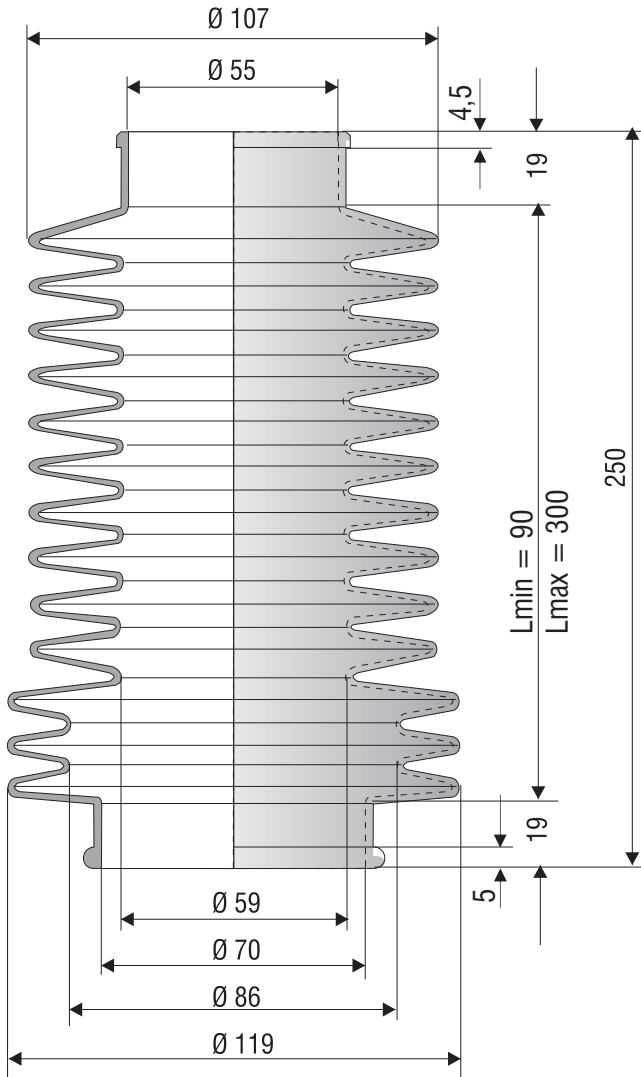

**F 1248 NBR**

13 Falten  
13 Folds

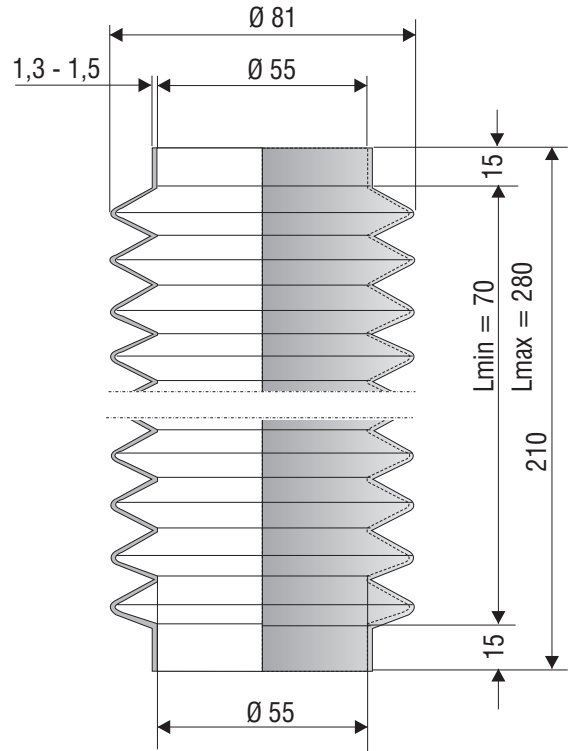

**F 2006 NBR**

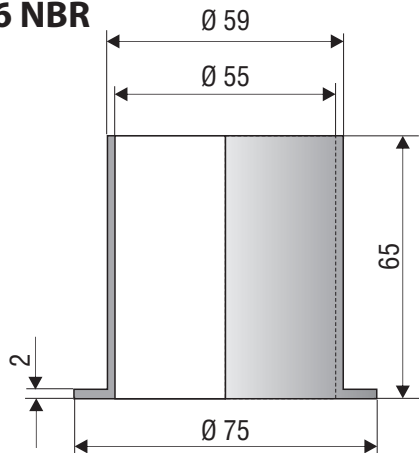

**F 1252 NBR**

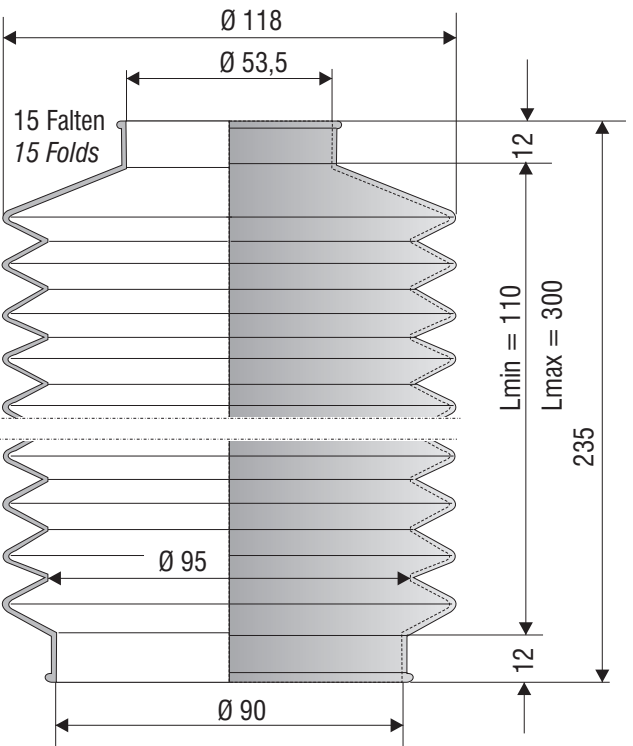



# Vulkanisierte Faltenbälge / Moulded Bellows

## Ø 56 - 59 mm

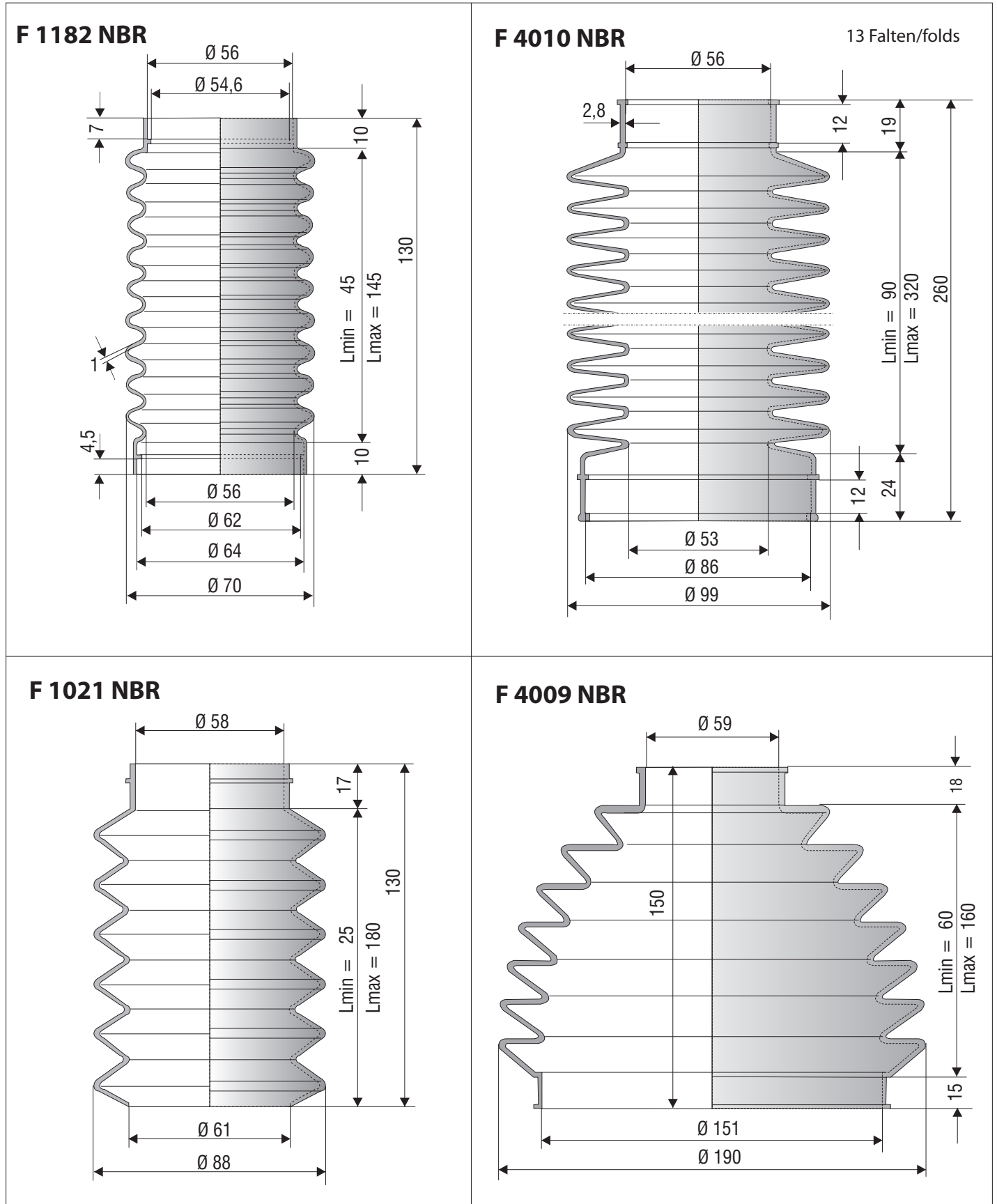



# Vulkanisierte Faltenbälge / Moulded Bellows

Ø 60 mm

**F 9004 NBR**

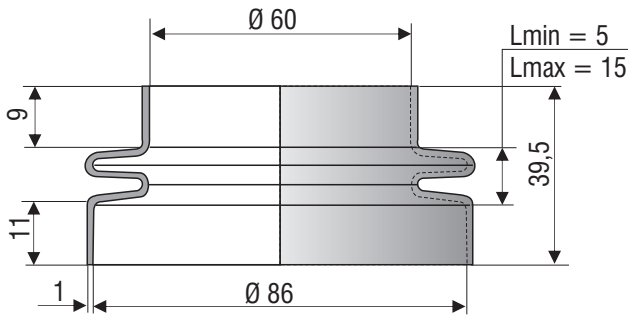

**F 1027 NBR**

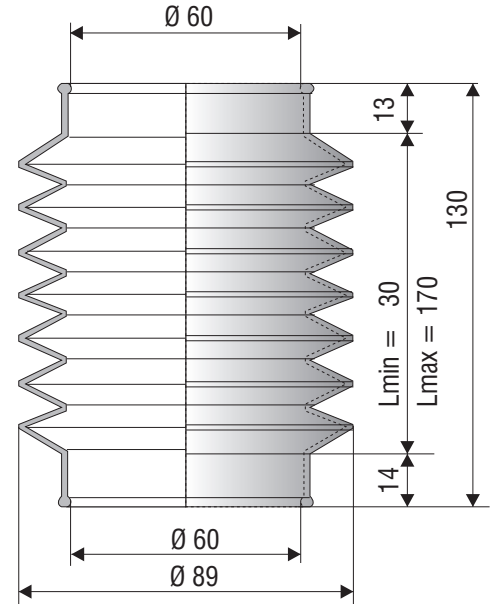

**F 1031 NBR**

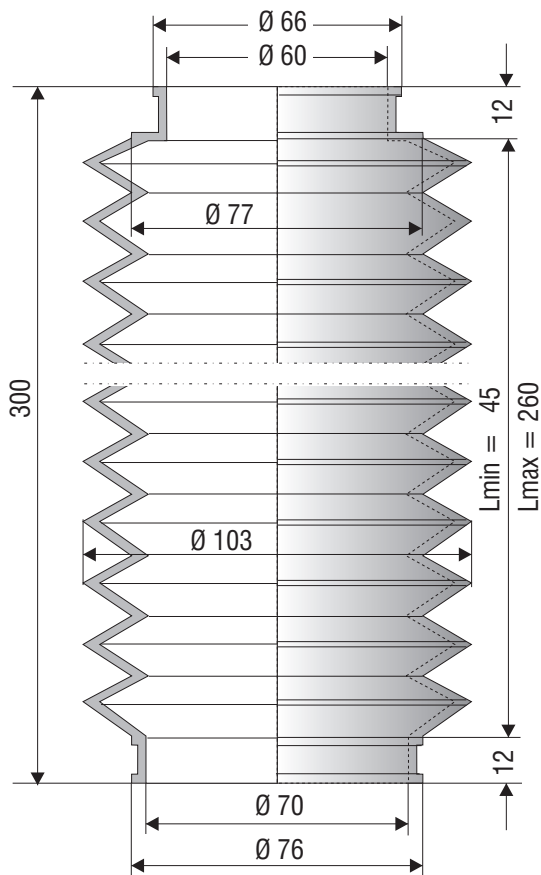

**F 1207 NBR**

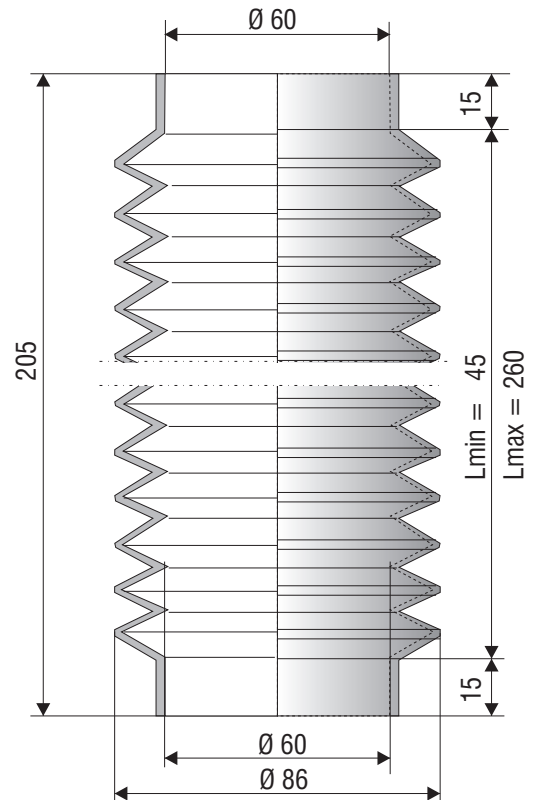



# Vulkanisierte Faltenbälge / Moulded Bellows

Ø 60 - 62 mm

**F 2001 Si (rot/red)**  
**F 2001 NBR**

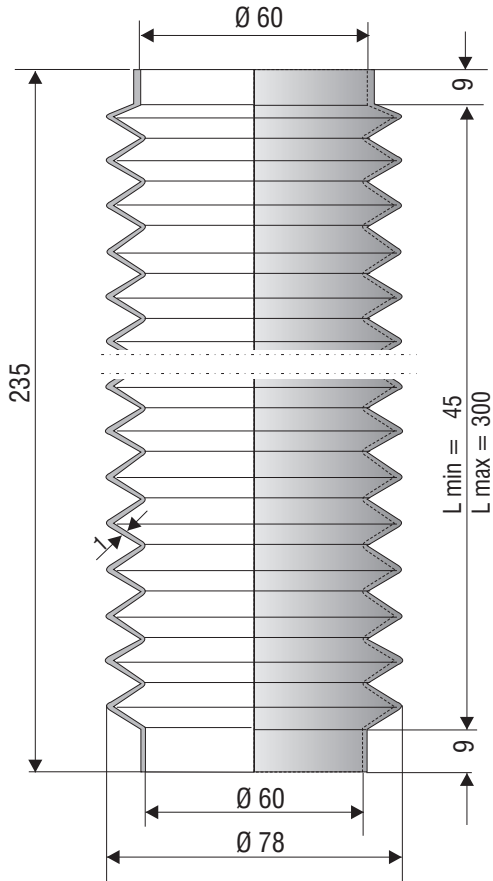

**F 1147 NBR**

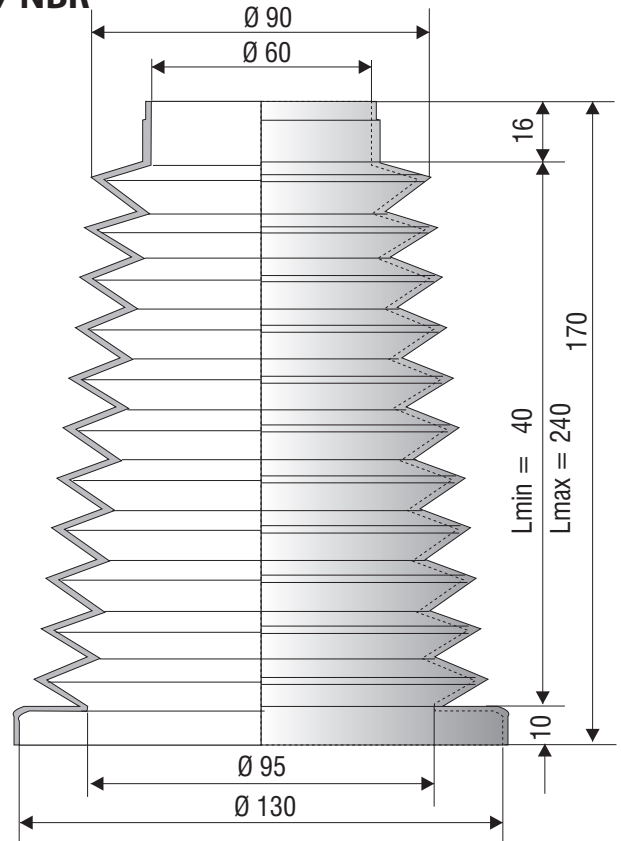

**F 9002 NBR**

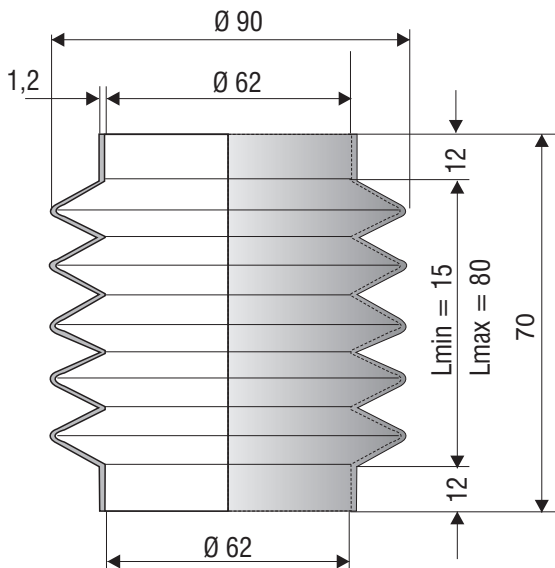

**F 4008 NBR**

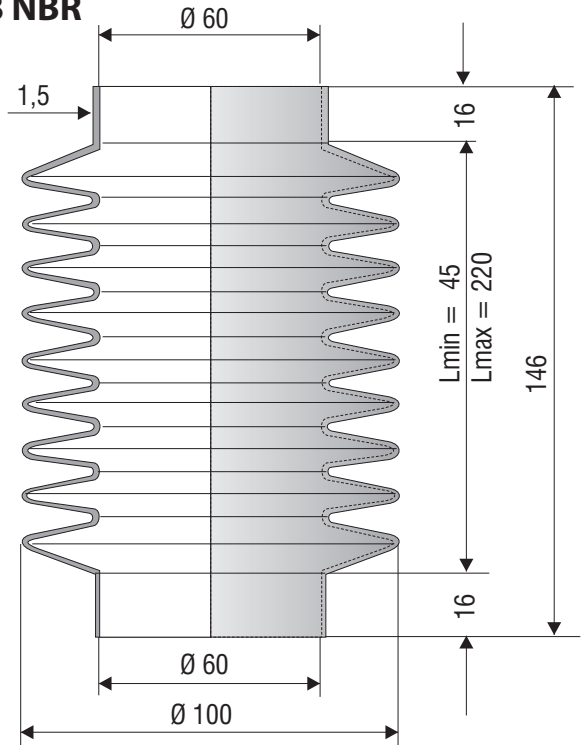





# Vulkanisierte Faltenbälge / Moulded Bellows

Ø 62 - 65 mm

**F 1244 NBR**

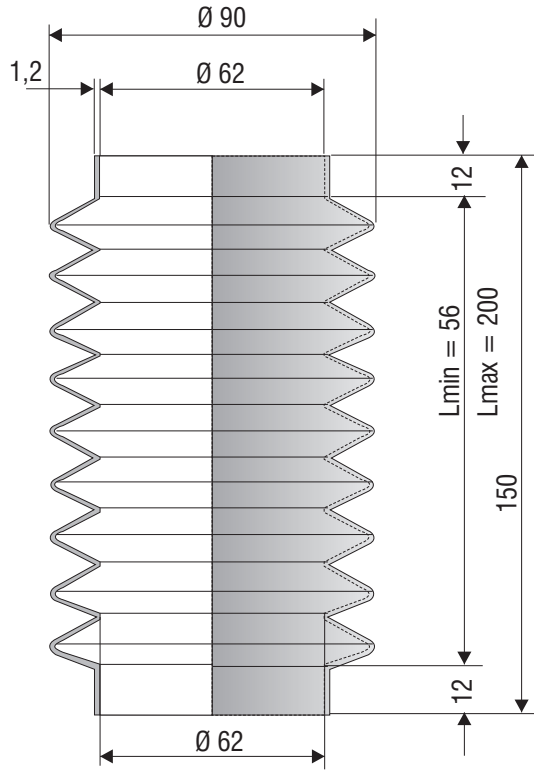

**F 1239 NBR**

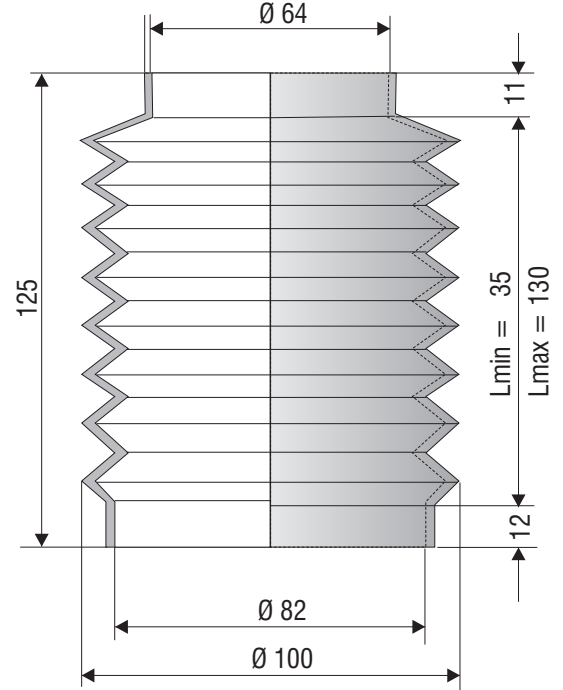

**F 1222 NBR**

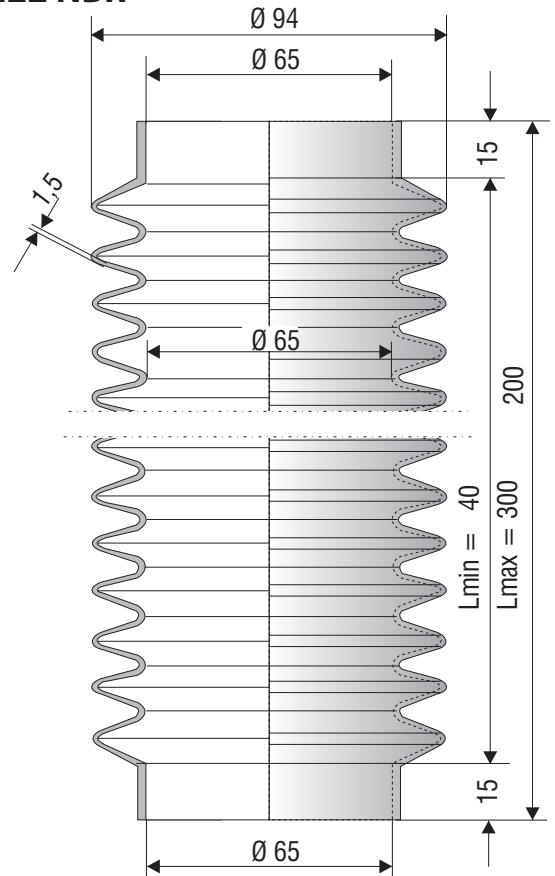

**F 1159 NBR**

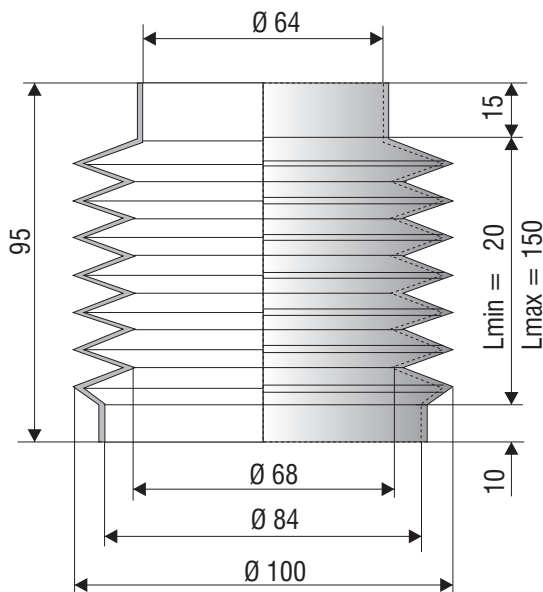



# Vulkanisierte Faltenbälge / Moulded Bellows

## Ø 65 - 70 mm

**F 4064 NBR**

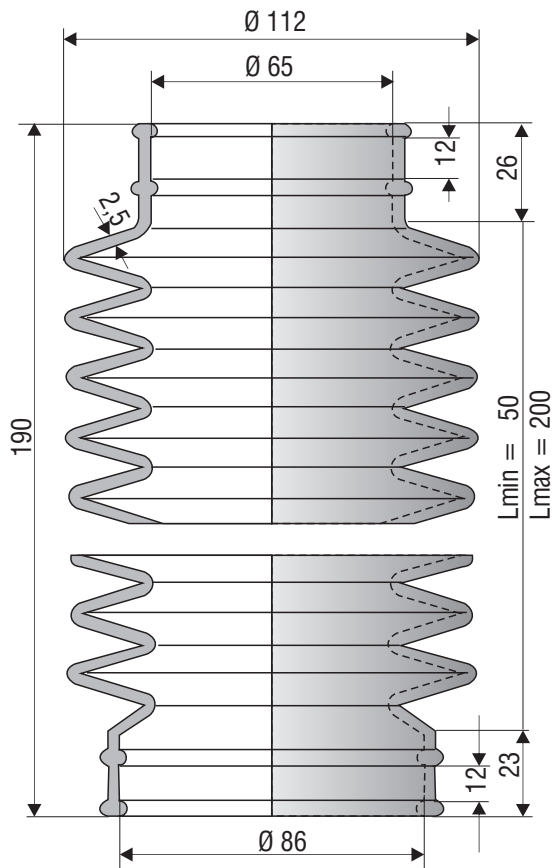

**F 1088 NBR**

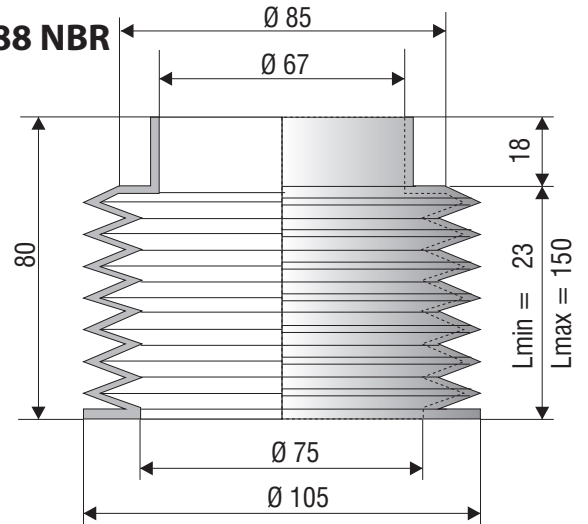

**F 4005 NBR**

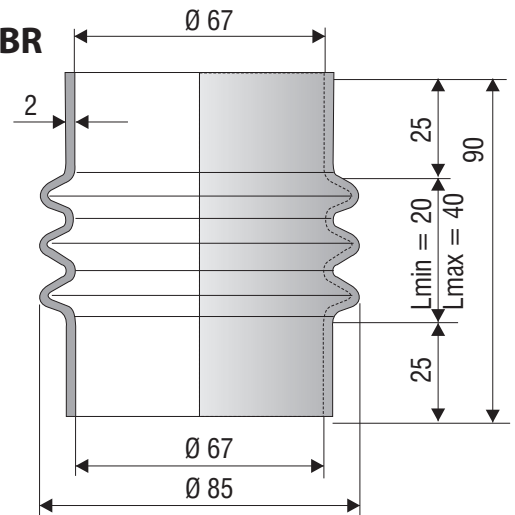

**F 1148 NBR**

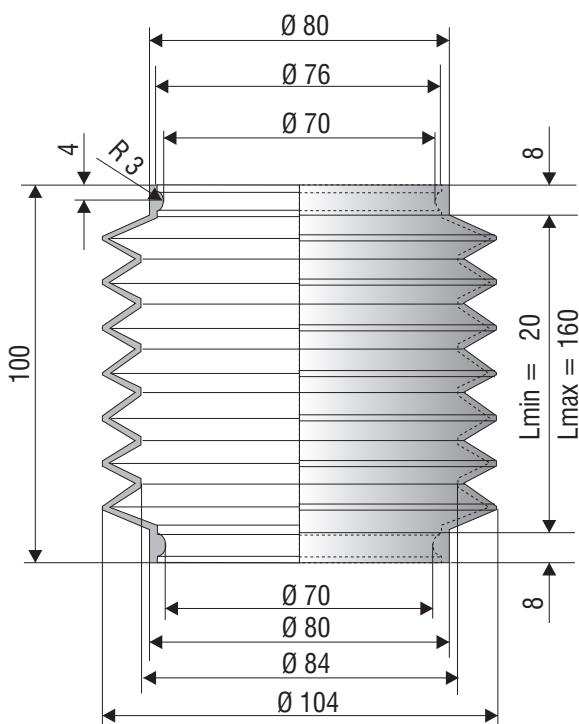

**F 1091 NBR**

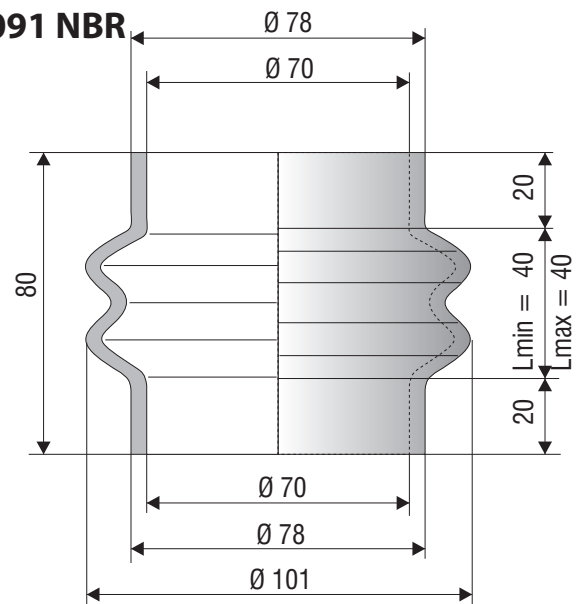



# Vulkanisierte Faltenbälge / Moulded Bellows

## Ø 70 - 71 mm

### F 1186 NBR

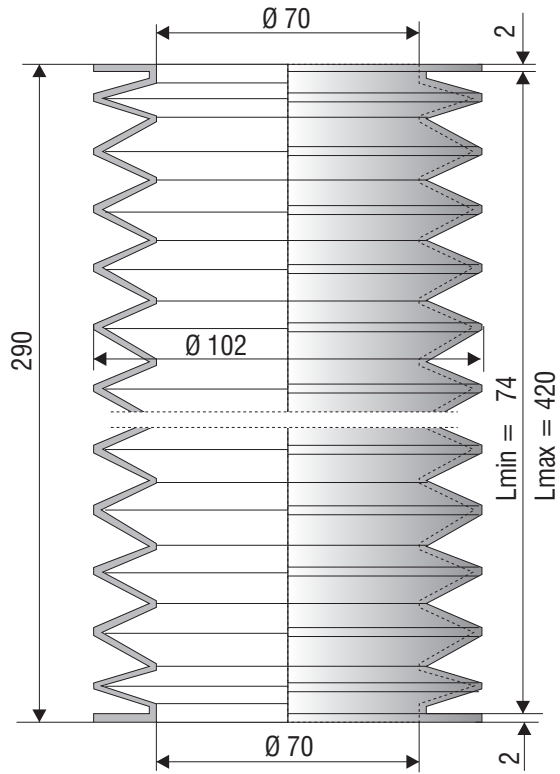

### F 1211 NBR

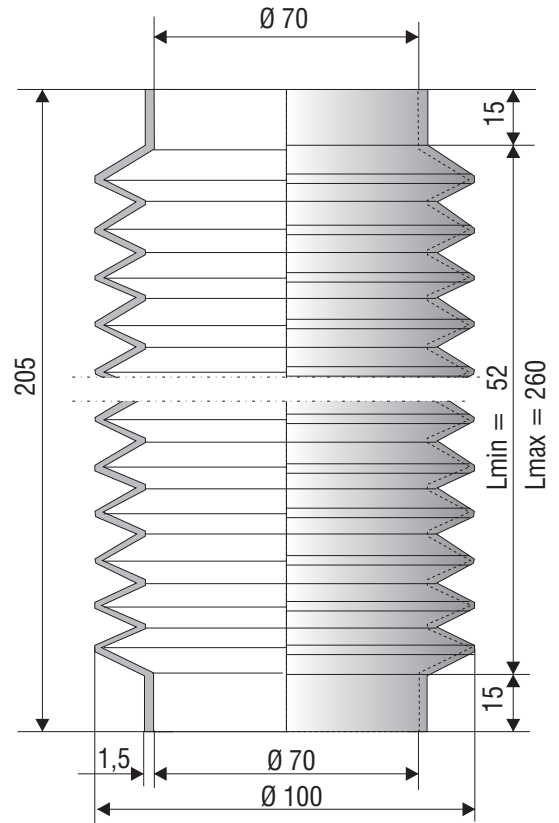

### F 1528 NBR

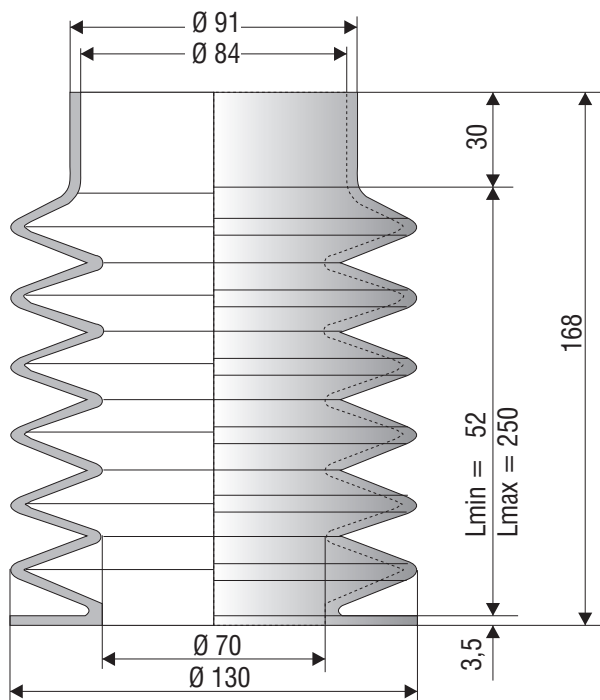

### F 1169 NBR

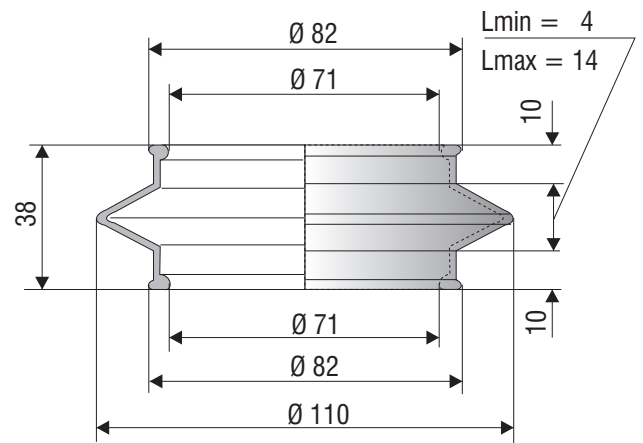



# Vulkanisierte Faltenbälge / Moulded Bellows

**Ø 70 - 73 mm**

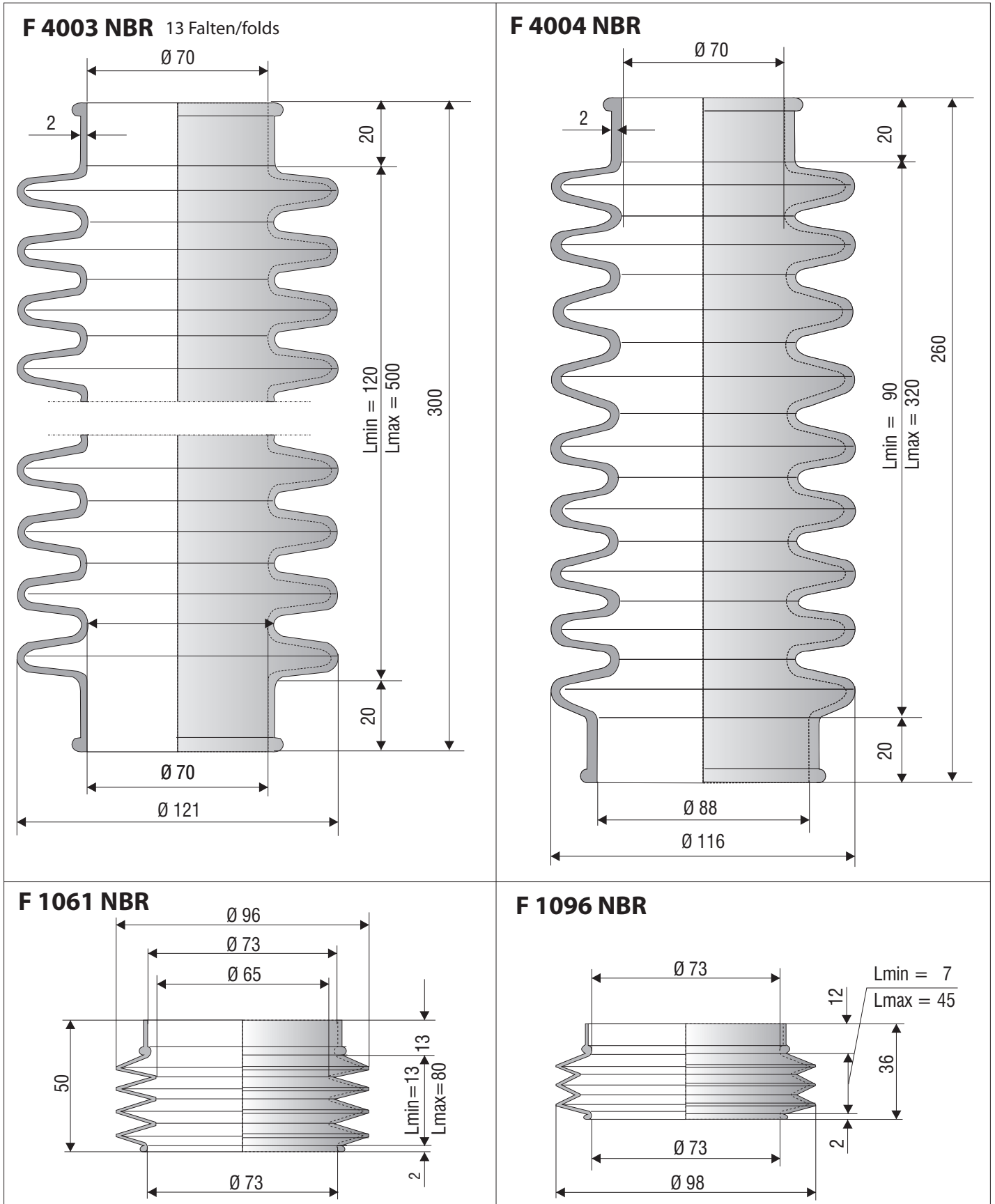



# Vulkanisierte Faltenbälge / Moulded Bellows

**Ø 72 - 75 mm**

**F 1049 NBR**

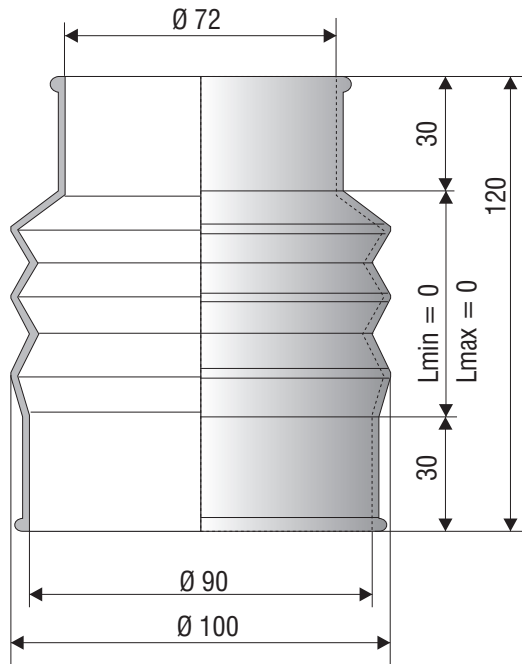

**F 4057 NBR**

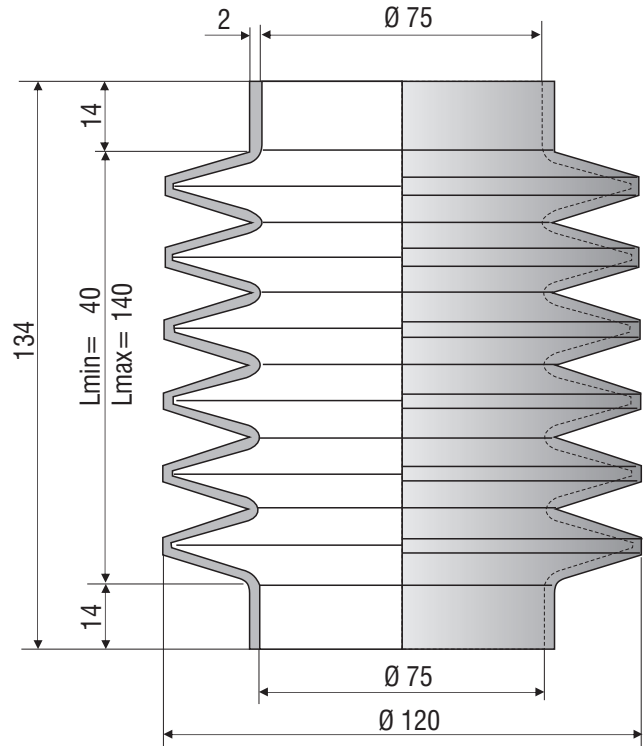

**F 2067 NBR**

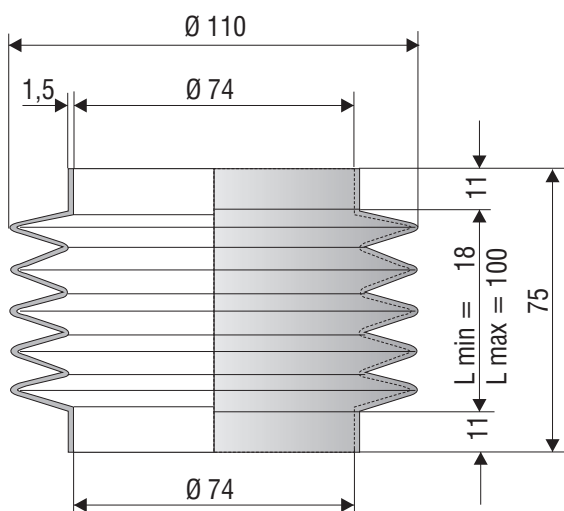

**F 1109 NBR**

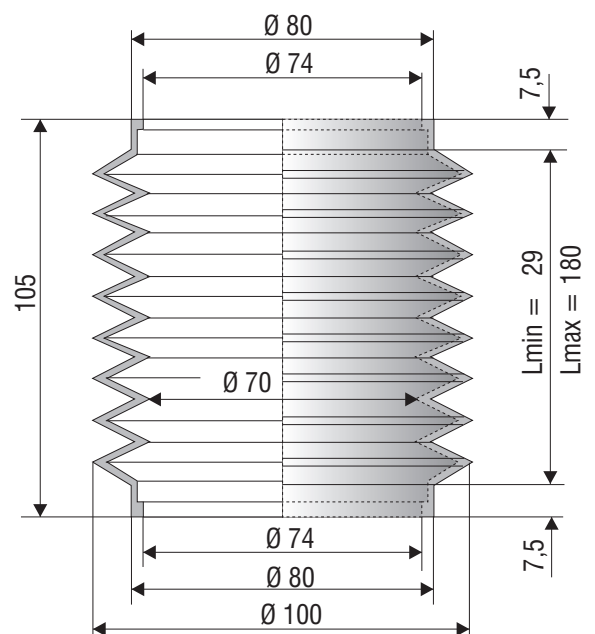



# Vulkanisierte Faltenbälge / Moulded Bellows

## Ø 75 - 79 mm

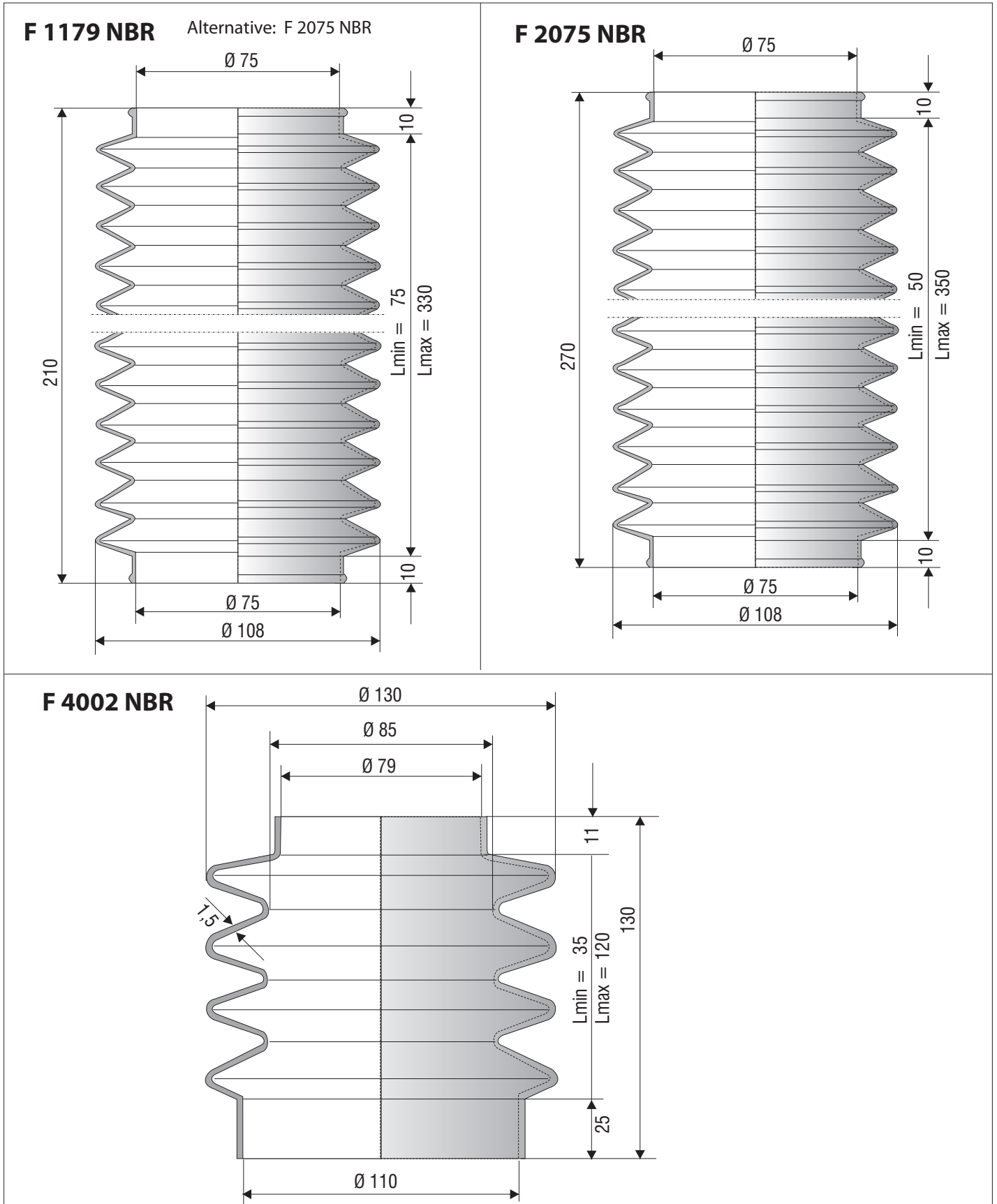



# Vulkanisierte Faltenbälge / Moulded Bellows

**Ø 80 mm**

**F 1224 NBR**

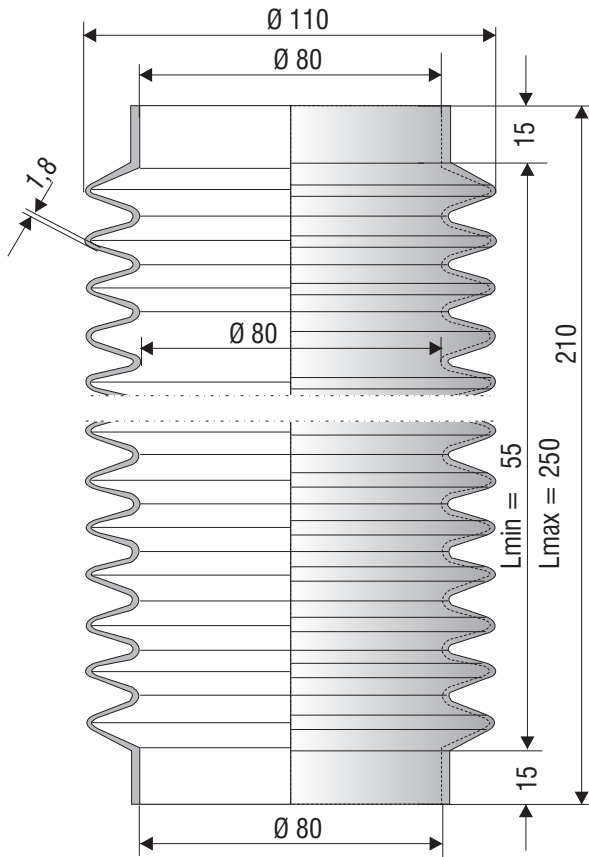

**F 4001 NBR**

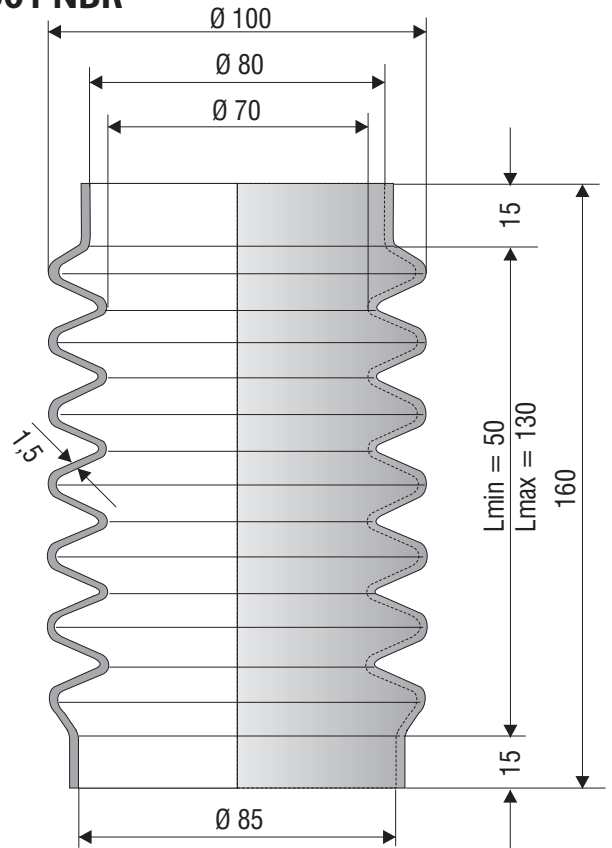

**F 1164 NBR**

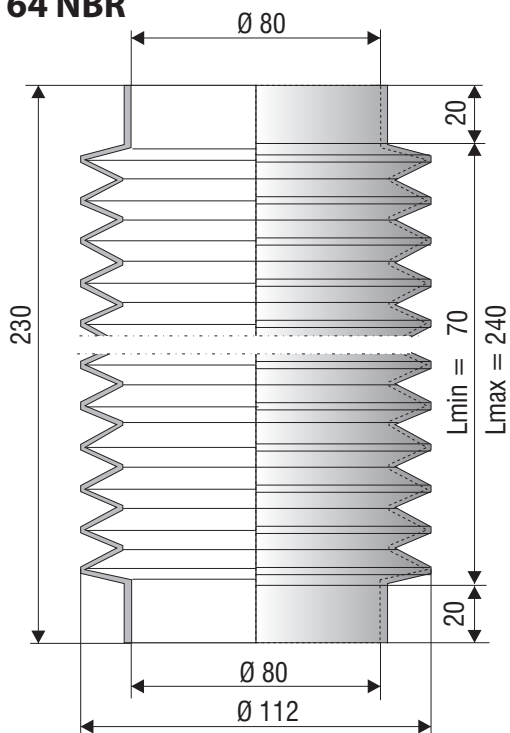

**F 1197 NBR**

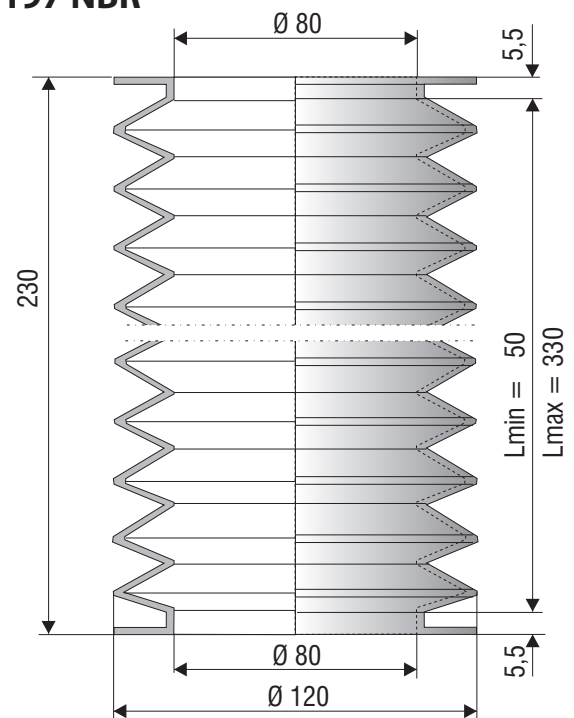



# Vulkanisierte Faltenbälge / Moulded Bellows

**Ø 80 - 85 mm**

**F 1225 NBR**

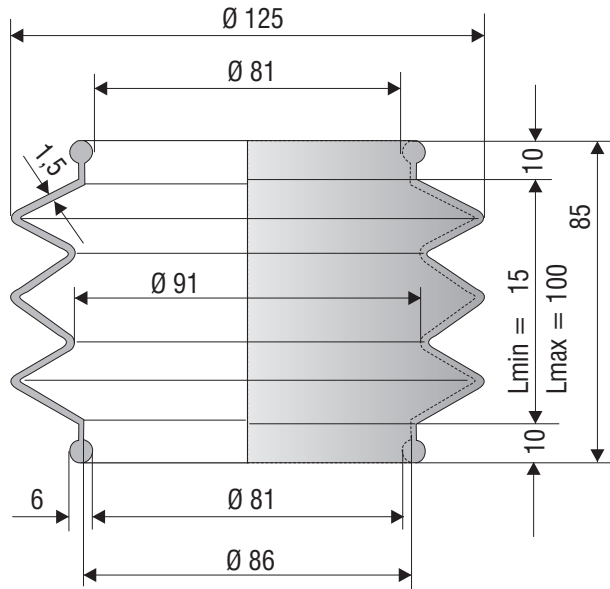

**F 1201 NBR + F 1201 CR**

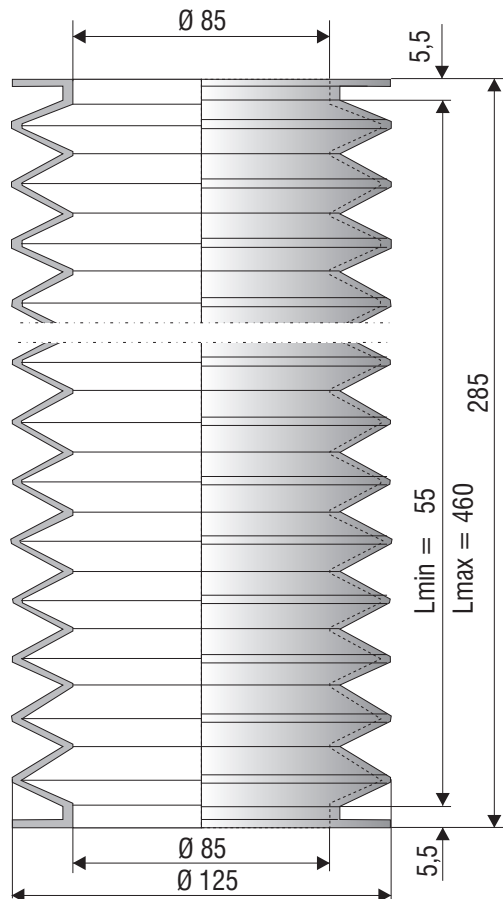

**F 1221 NBR**

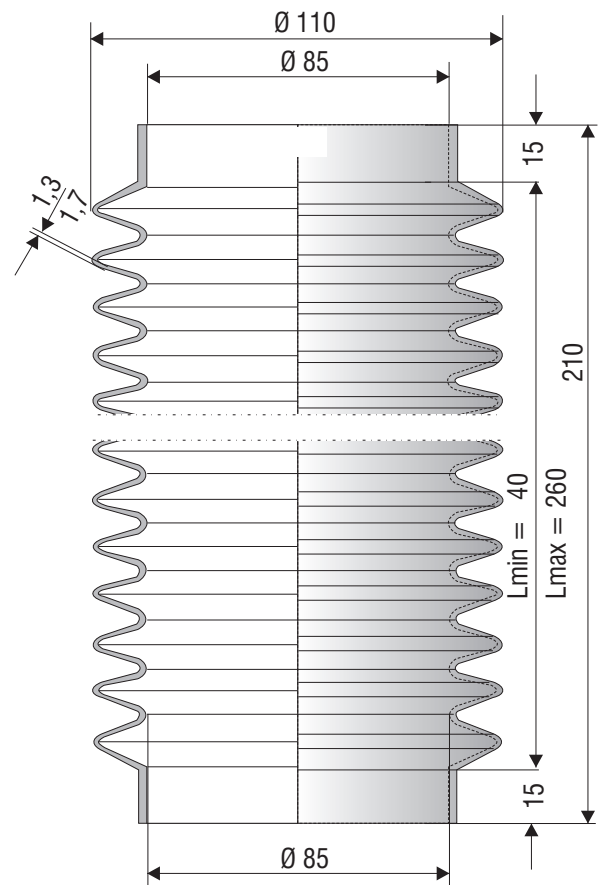





# Vulkanisierte Faltenbälge / Moulded Bellows

**Ø 85 - 92 mm**

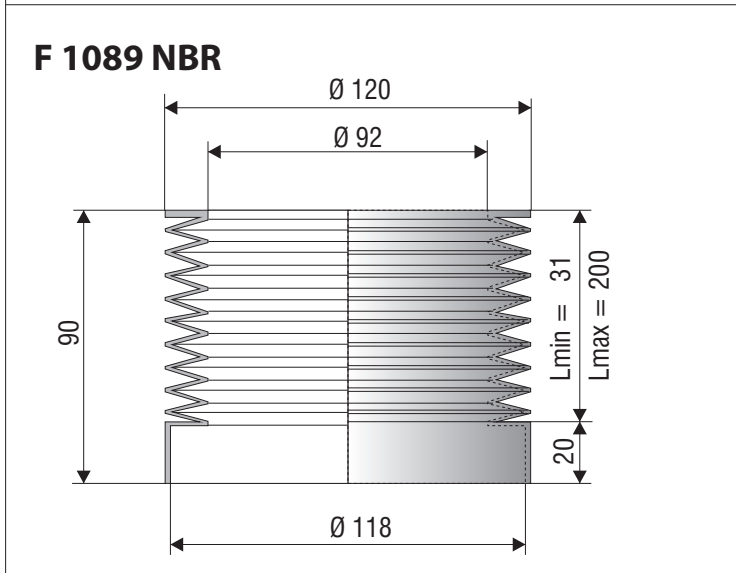
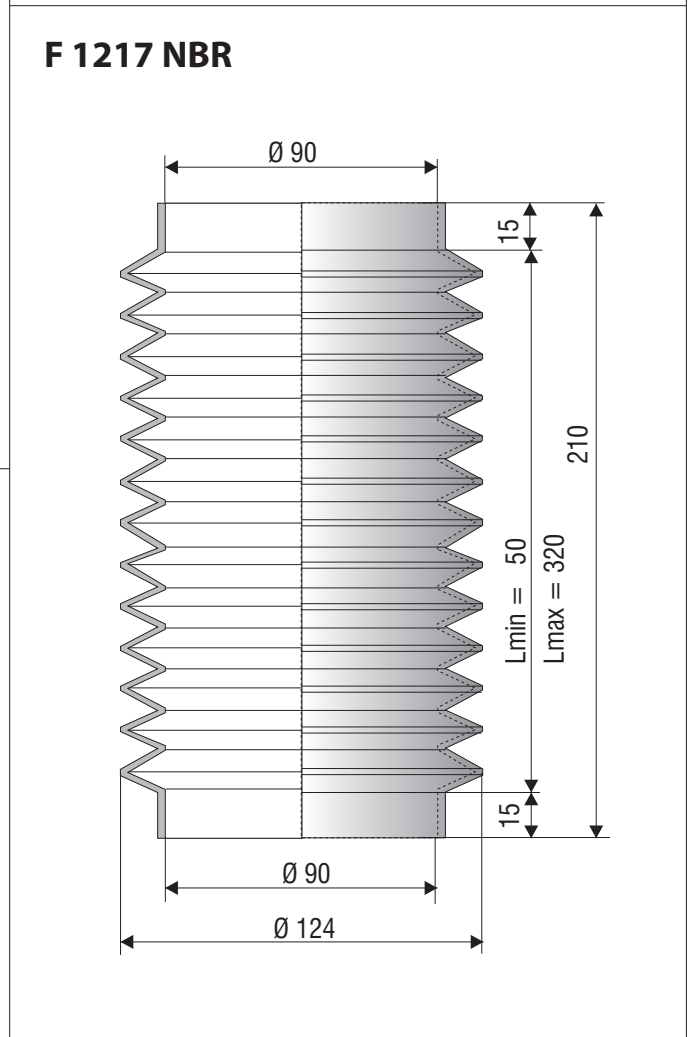
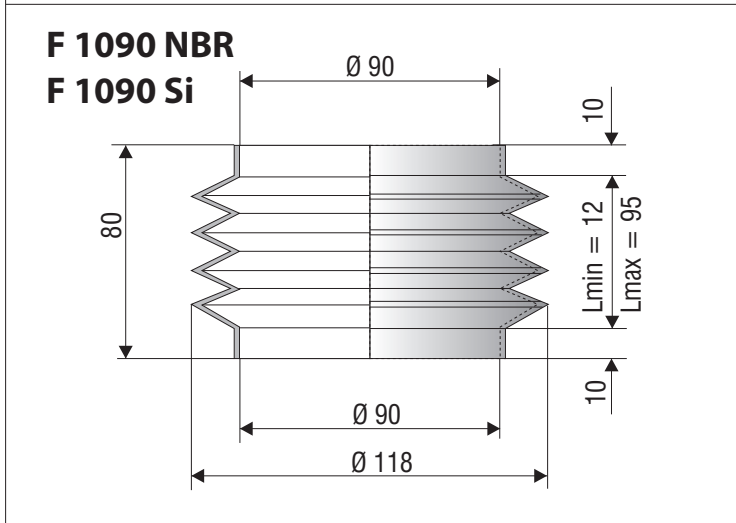
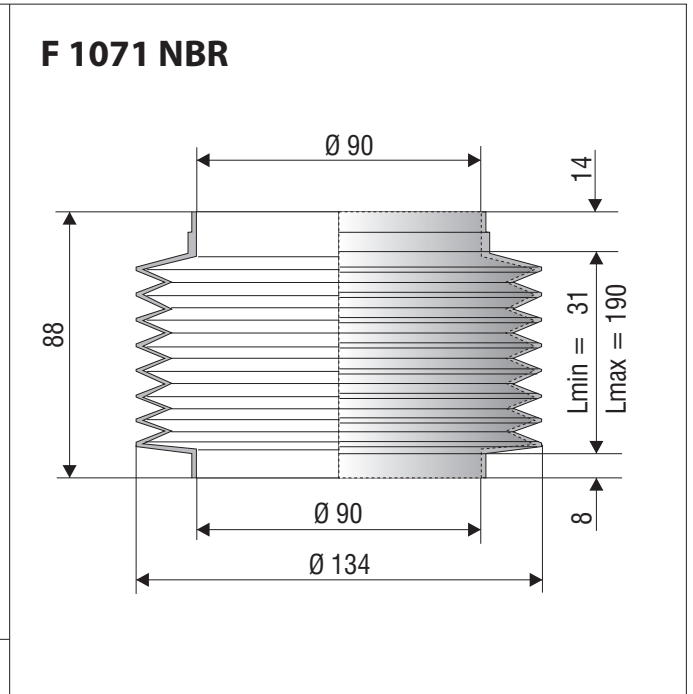
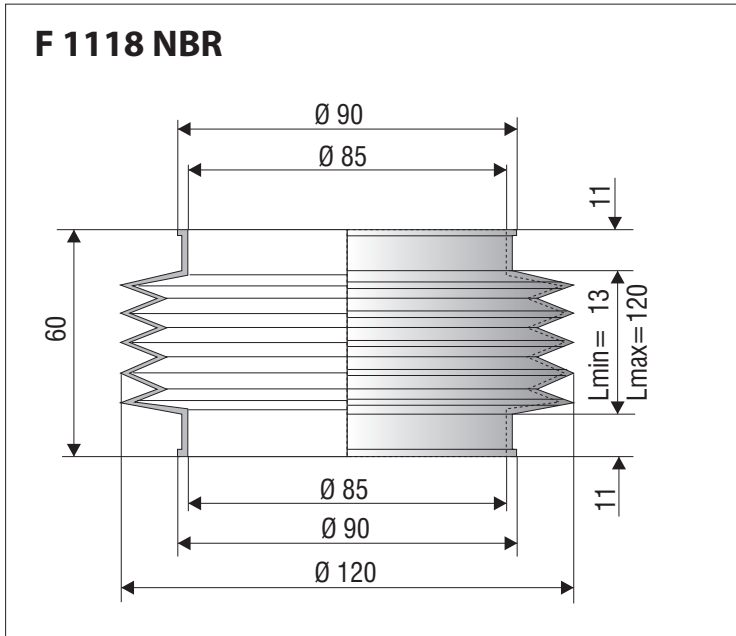



# Vulkanisierte Faltenbälge / Moulded Bellows

Ø 95 - 100 mm

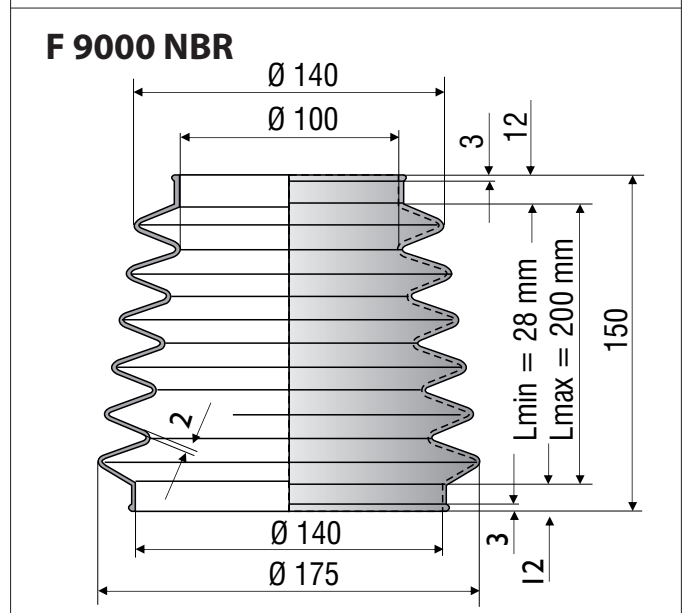
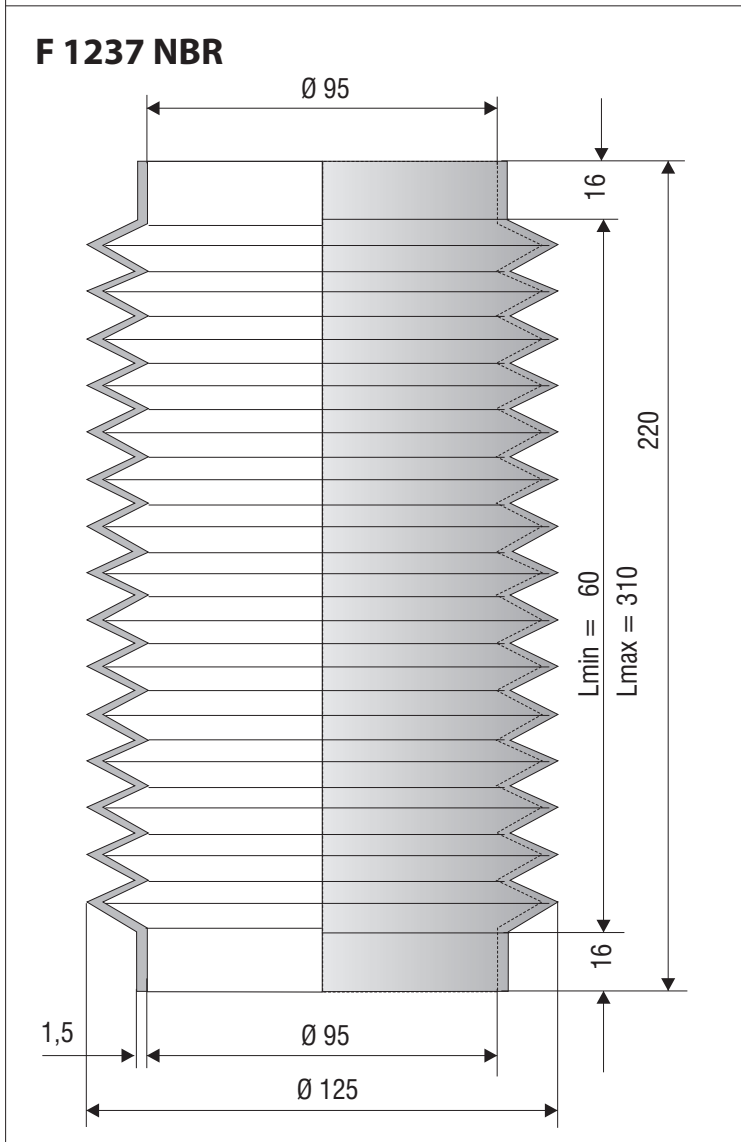
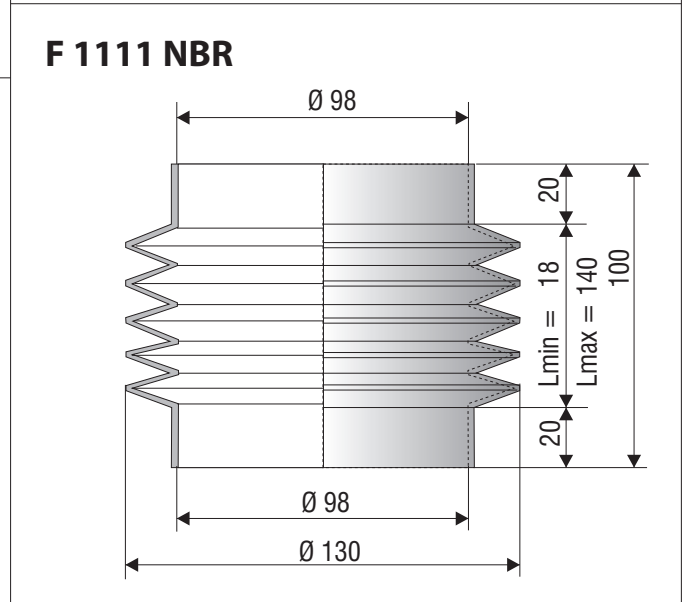
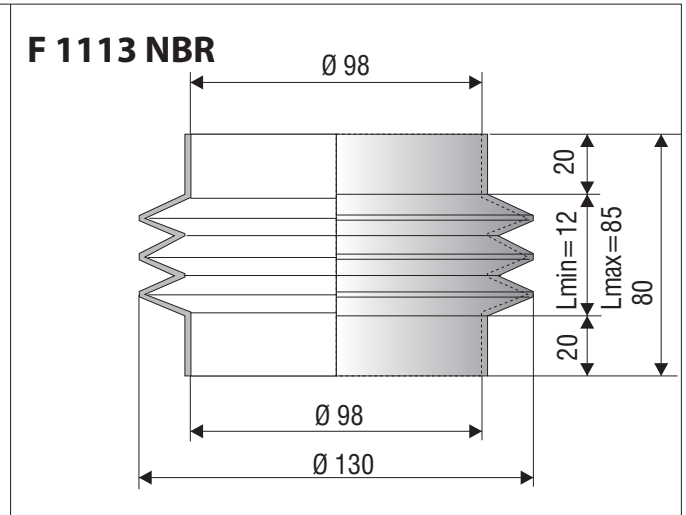
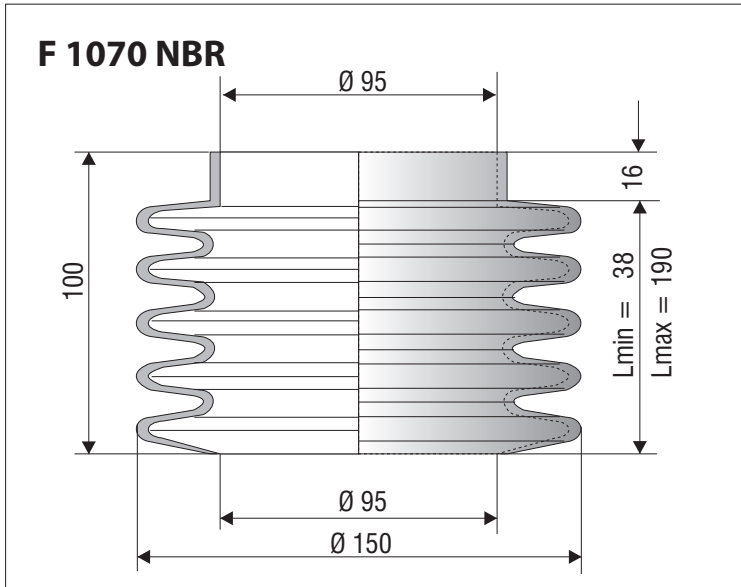



# Vulkanisierte Faltenbälge / Moulded Bellows

**Ø 100 mm**

**F 1074 NBR**

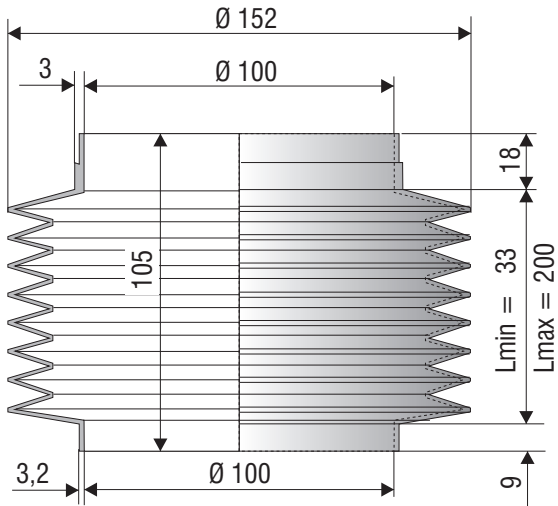

**F 4059 NBR**

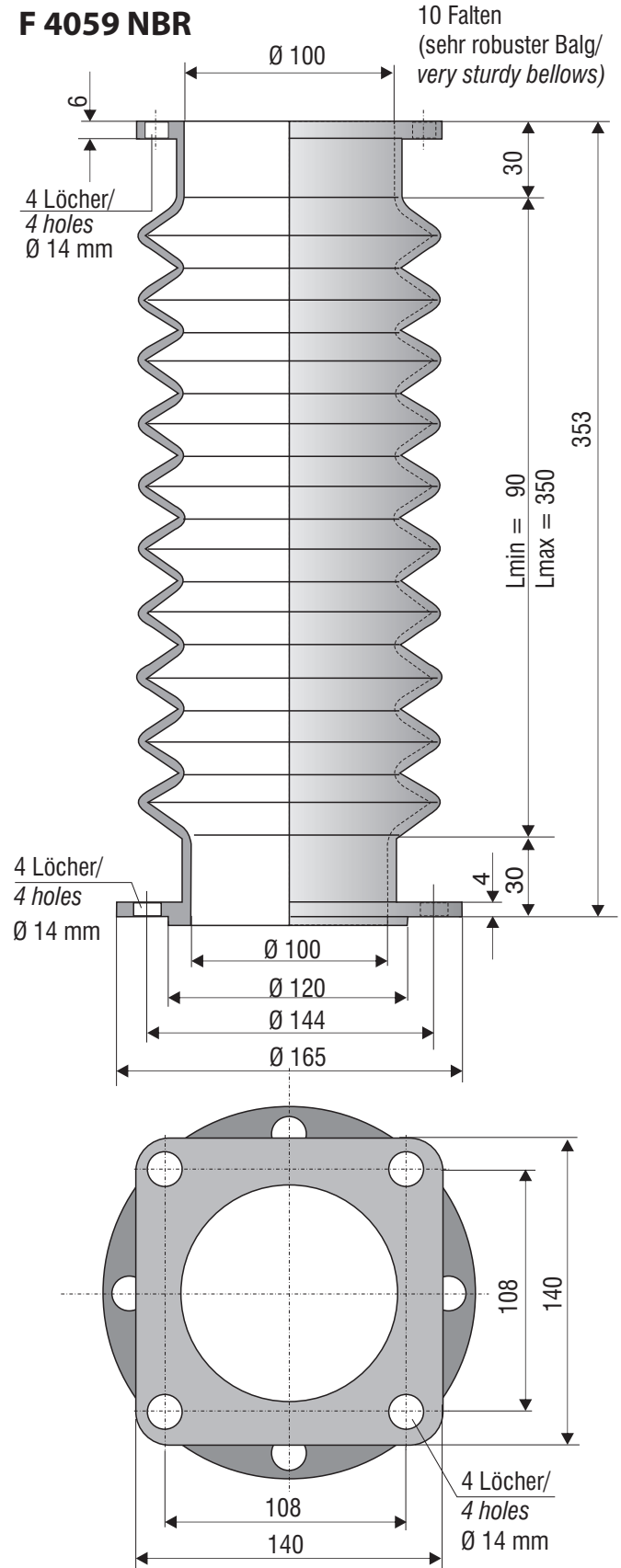

**F 1218 NBR**

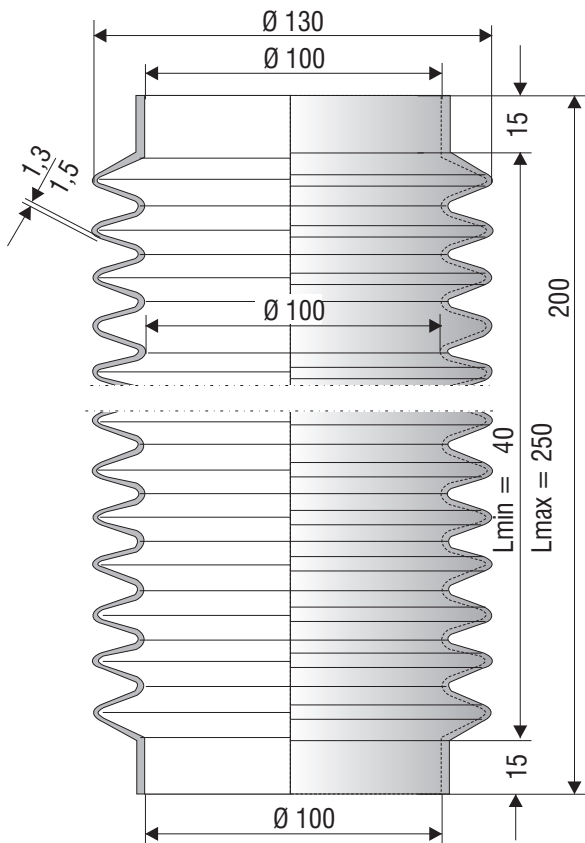



# Vulkanisierte Faltenbälge / Moulded Bellows

Ø 100 - 110 mm

**F 1085 NBR**

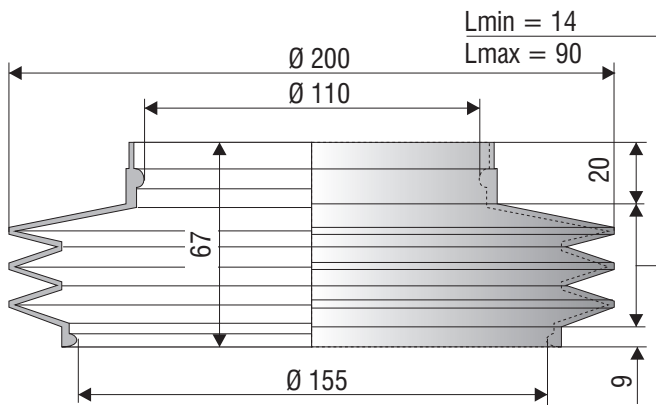

**F 4056 NBR**

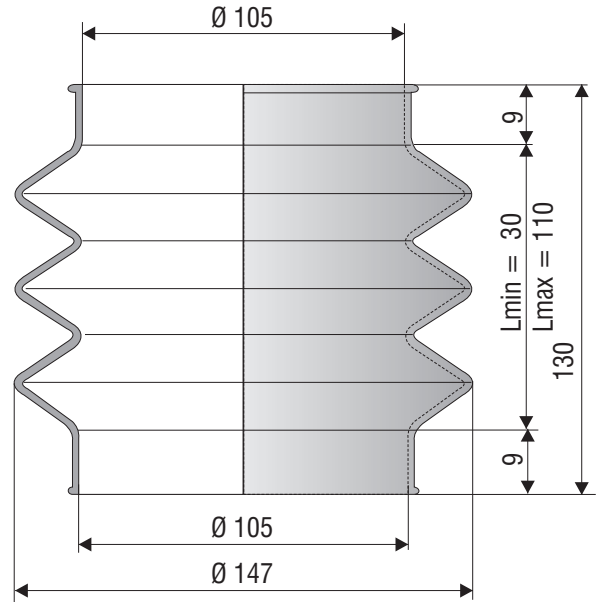

**F 4060 NBR**

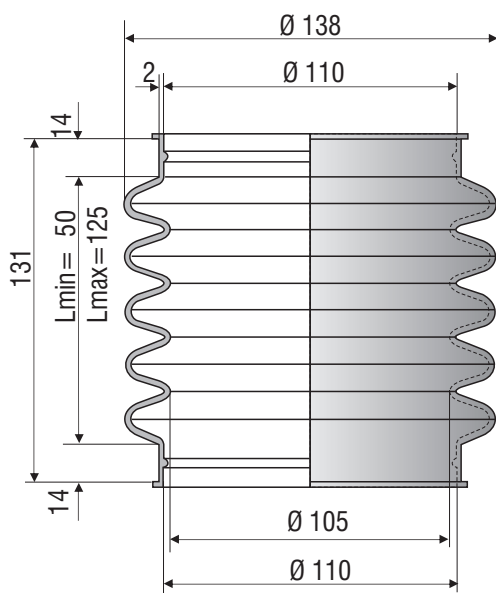

**F 1216 NBR**

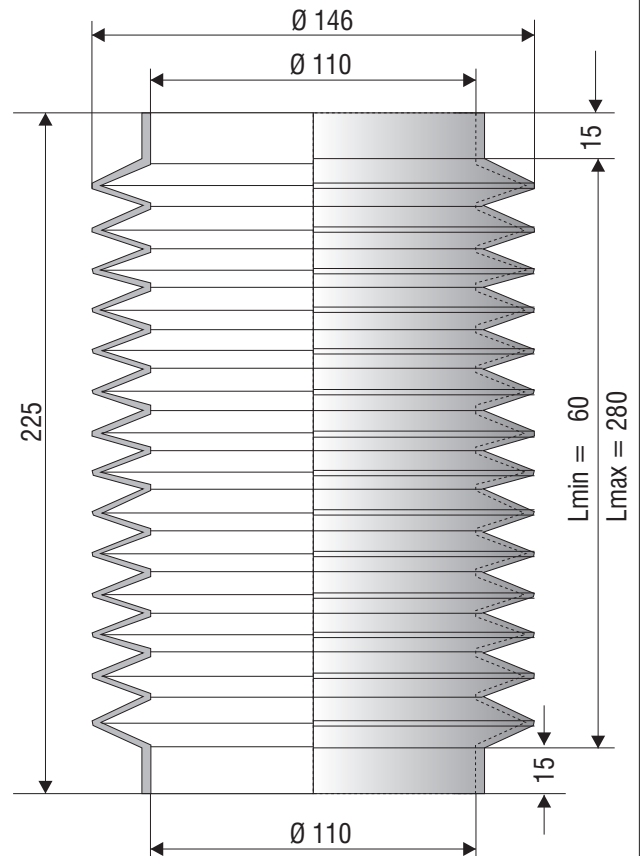



# Vulkanisierte Faltenbälge / Moulded Bellows

Ø 114 - 130 mm

**F 1068 NBR**

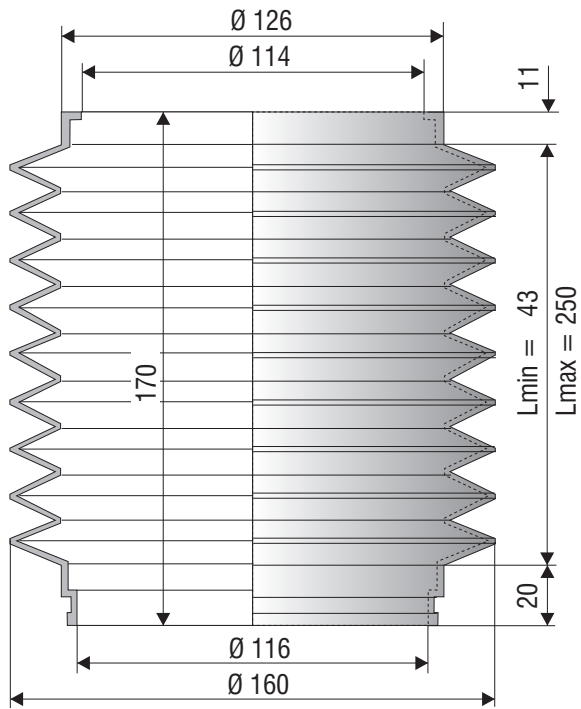

**F 1172 NBR**

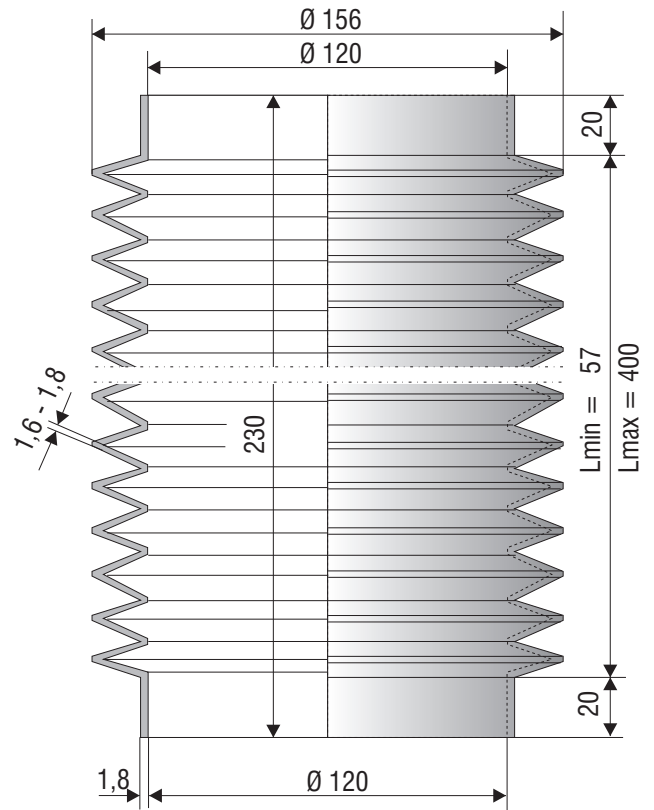

**F 1204 NBR**

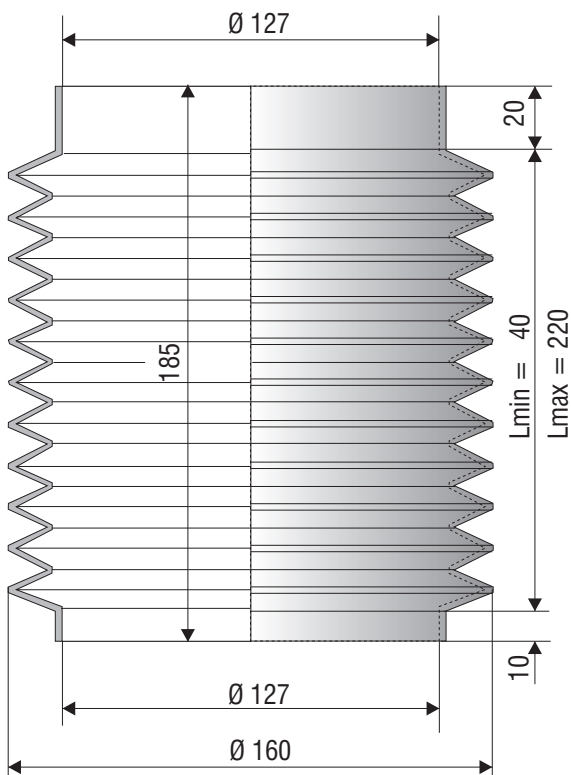

**F 1203 NBR**

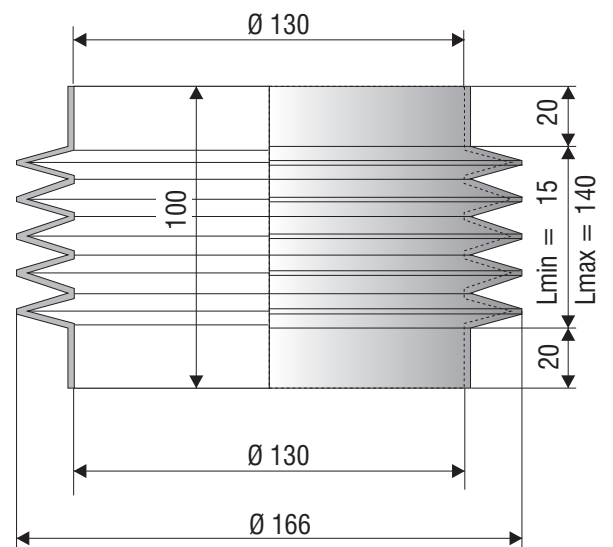



# Vulkanisierte Faltenbälge / Moulded Bellows

Ø 130 - 140 mm

**F 1170 NBR**

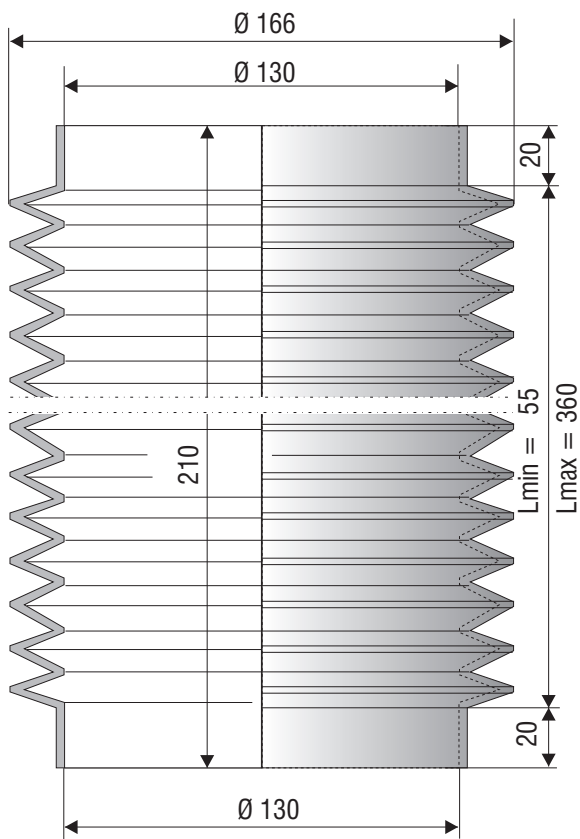

**F 1181 NBR**

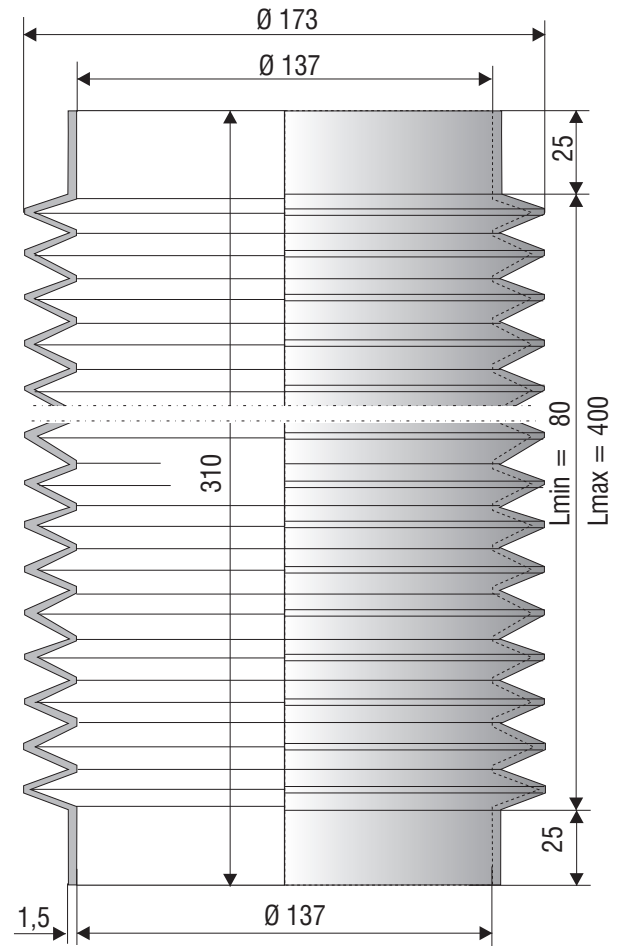

**F 1046 NBR**

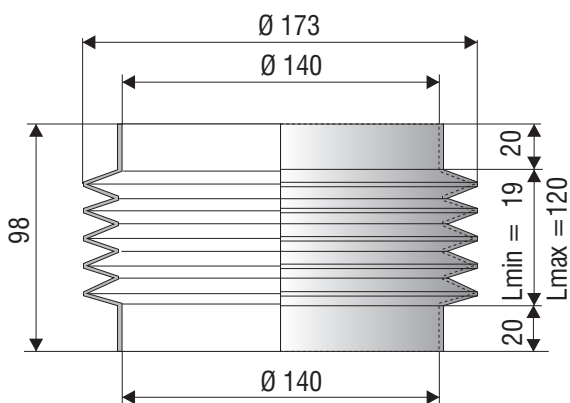

**F 1110 NR**

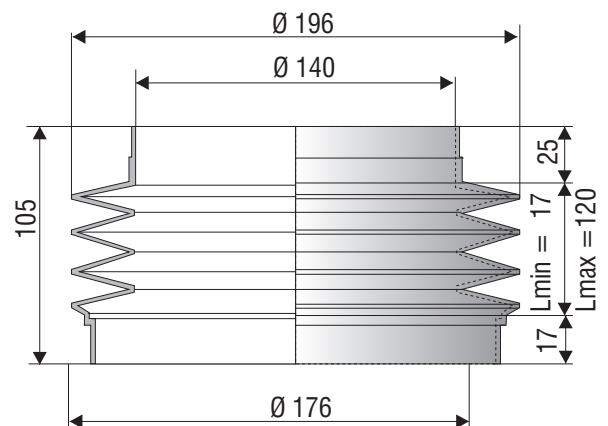



# Vulkanisierte Faltenbälge / Moulded Bellows

Ø 148 - 155 mm

**F 1082 NBR**

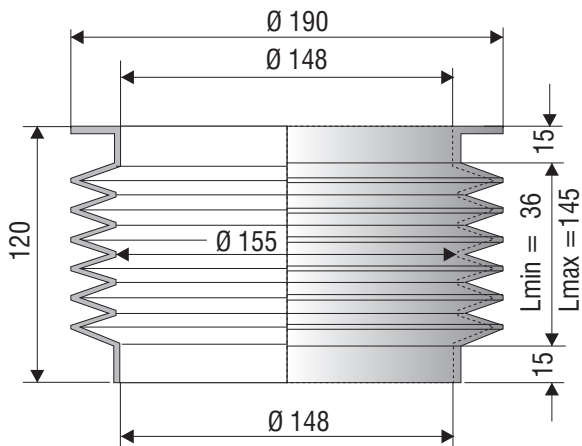

**F 1240 NBR**

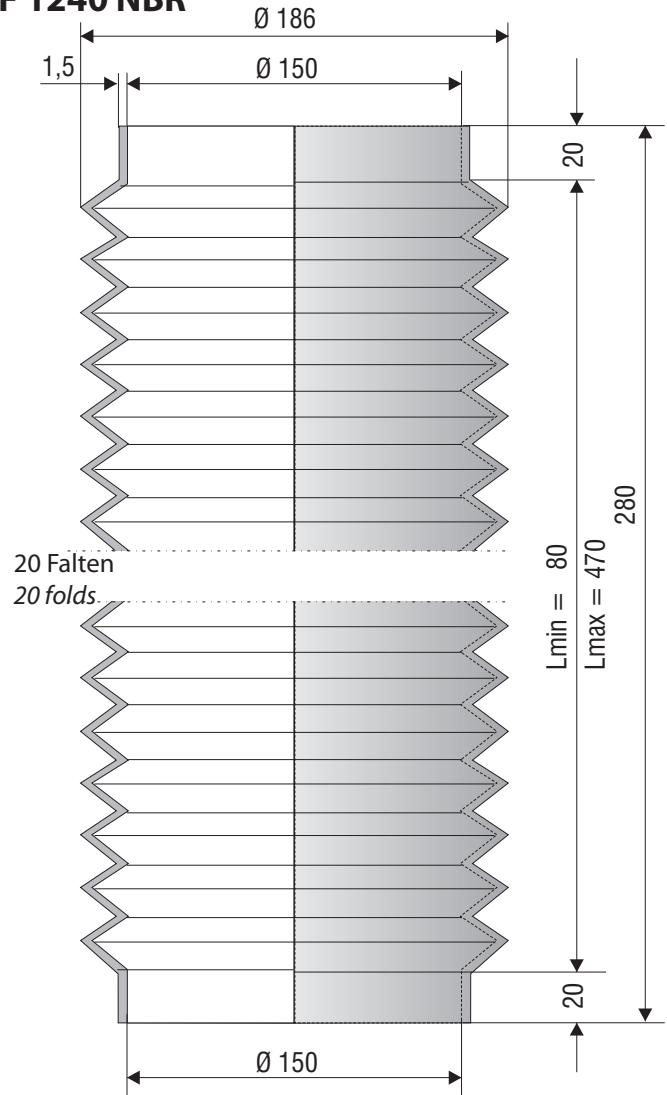

**F 1079 NBR**

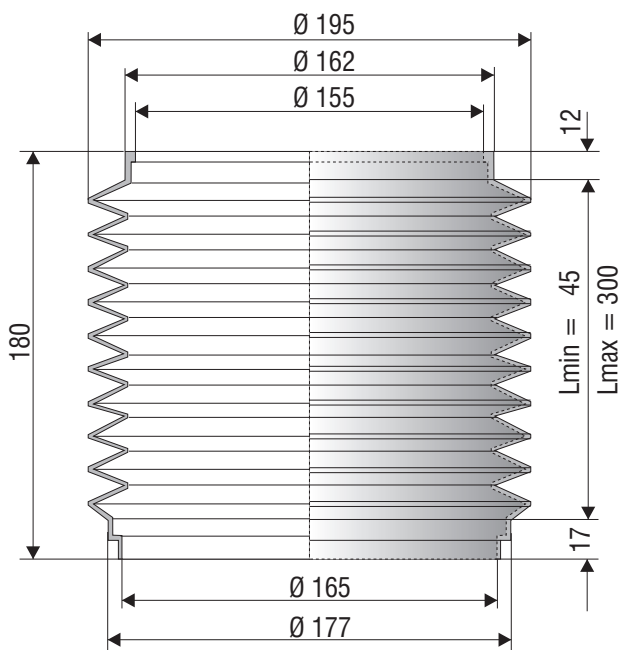

**F 1077 NBR**

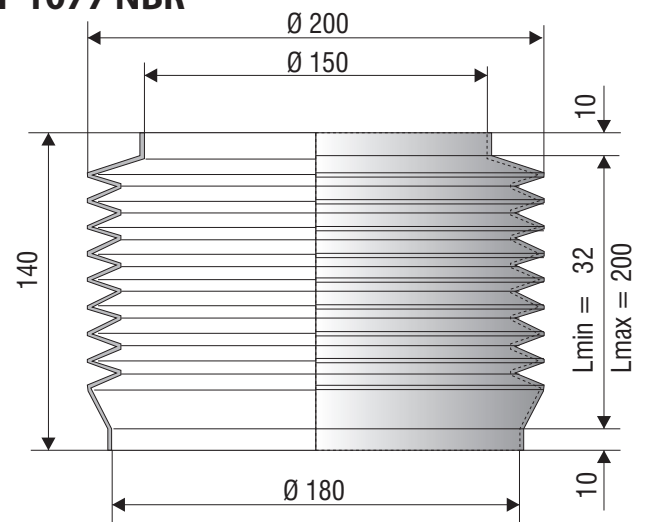



# Vulkanisierte Faltenbälge / Moulded Bellows

Ø 160 - 210 mm

**F 1066 NBR**

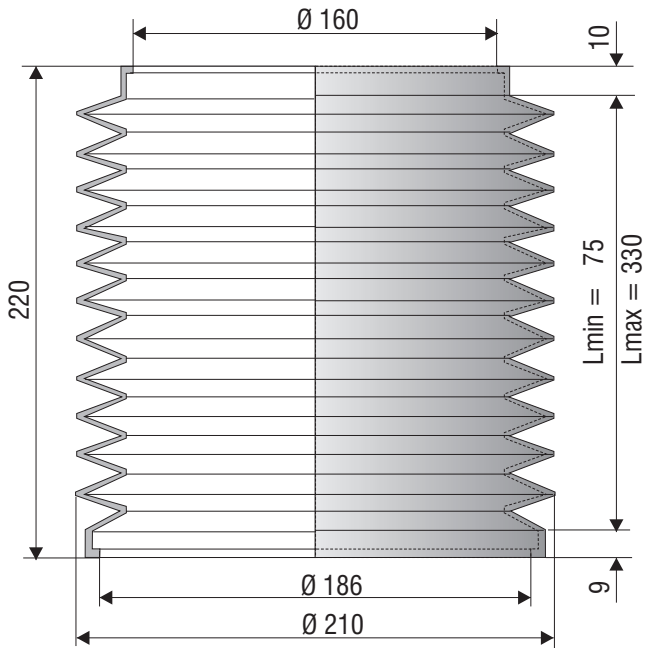

**F 1122 NBR**

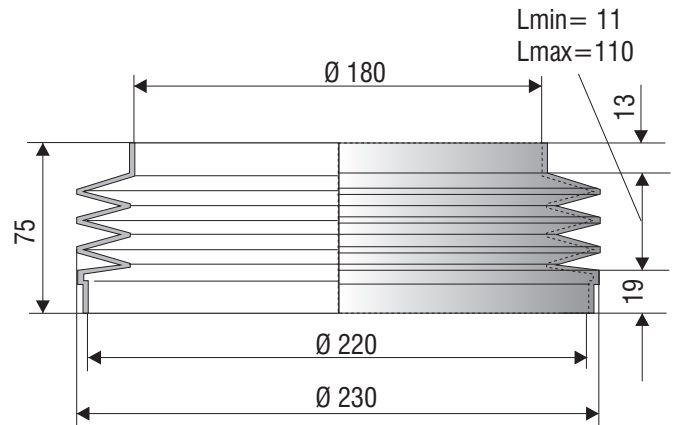

**F 1067 NBR**

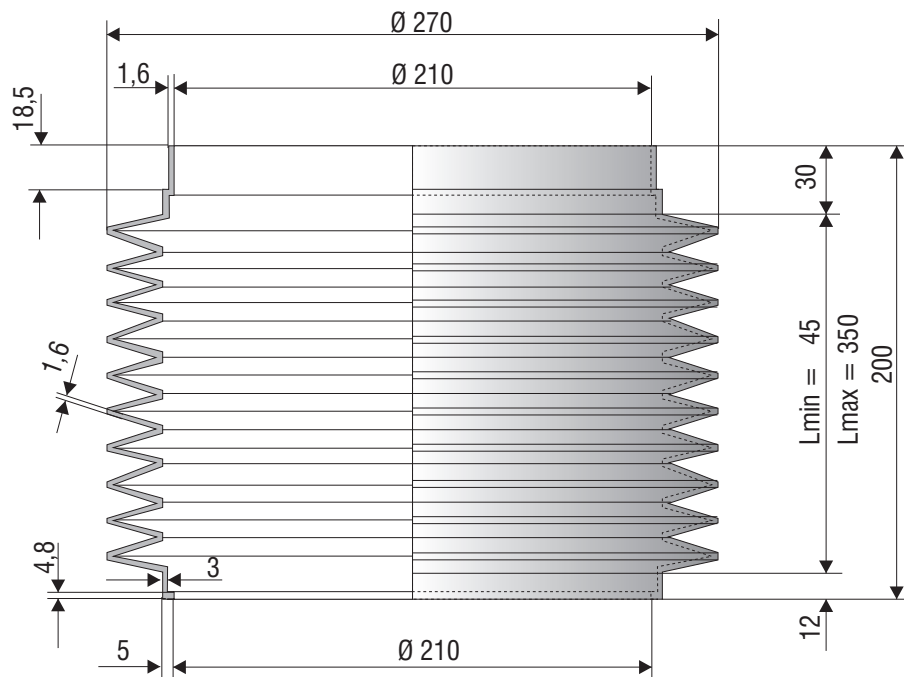





# Vulkanisierte Faltenbälge / *Moulded Bellows*

**Ø 260 mm**

