



STEINBOCK GmbH

Industrie-Ausrüstungen • Industrial Components

ORIGINAL FlexoLine

Flexible Luft- und Kühlmittelgelenkschläuche
Adjustable flexible Air and Coolant Hoses

FL 03

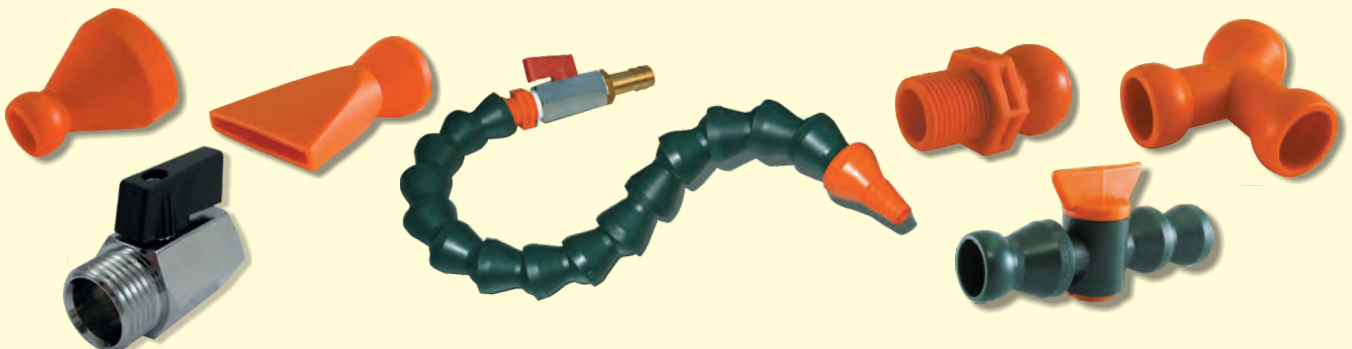



Änderungen im Sinne des
technischen Fortschritts vorbehalten

Alle Maße in mm

Subject to change without notice

All dimensions in mm

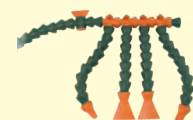

Copyright © 02/2016

ORIGINAL FlexoLine

Gelenkschläuche
Articulated Hoses



ORIGINAL FlexoLine

Gelenkschläuche Articulated Hoses

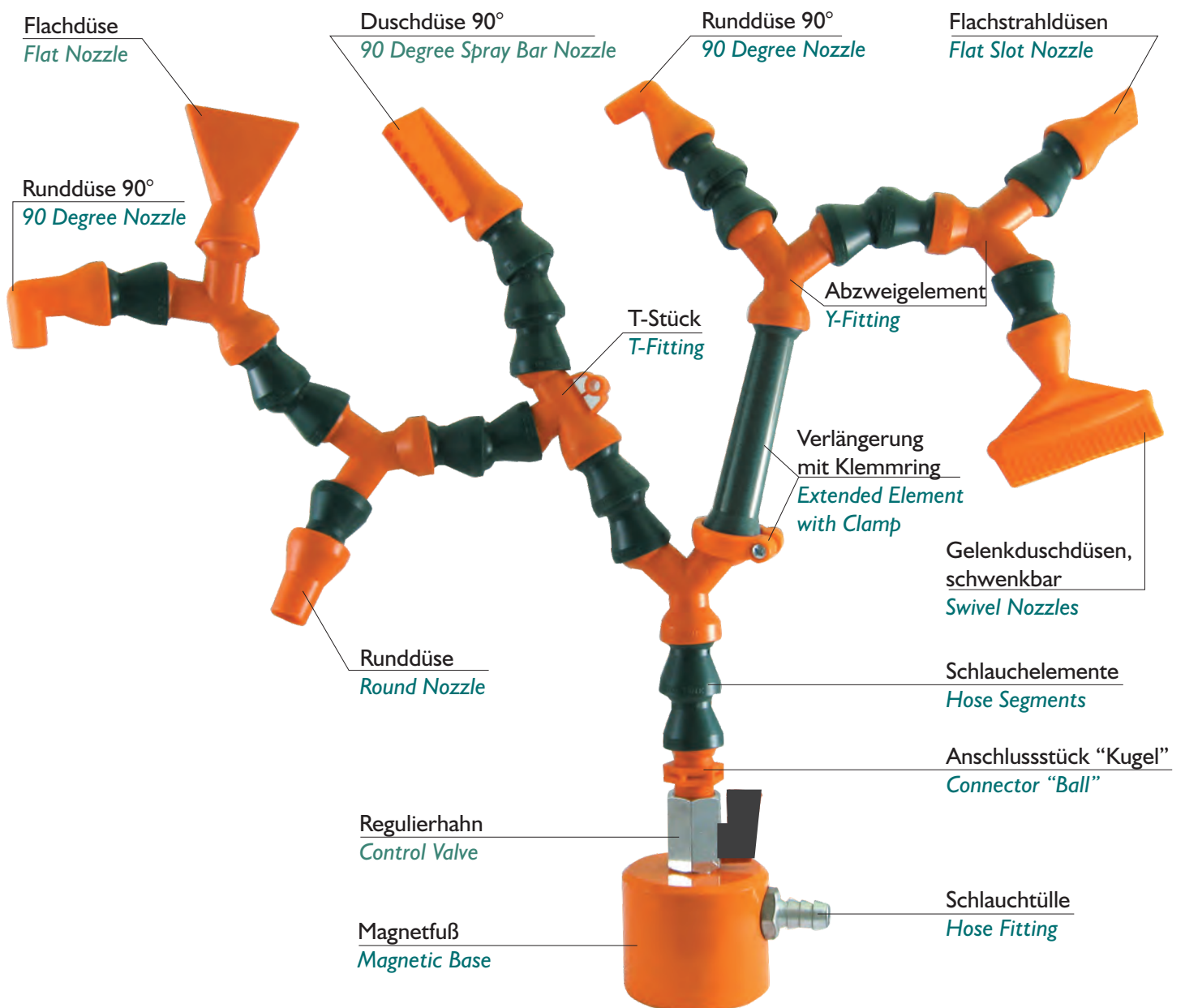

ORIGINAL FlexoLine

Gelenkschläuche / Articulated Hoses

Anwendungsbeispiele:

Original FlexoLine Gelenkschläuche haben sich optimal bewährt

- zur Kühlmittelzufuhr,
- zum Ausblasen von Werkstücken,
- zum Vereinzeln von Papierbögen,
- zum Absaugen von Flüssigkeiten.

Speziell an Bearbeitungszentren sowie Dreh-, Fräs-, Bohr-, Schleif- und Erodiermaschinen, wo hohe Biegefestigkeit, Positionsstabilität, gute chemische Beständigkeit, schnelle Montage und viele Kombinationsmöglichkeiten gefragt sind.

Besondere Vorteile:

- Sie sind punktgenau einstellbar und bringen flüssige oder gasförmige Medien genau dorthin, wo sie gebraucht werden.
- Vibrationsstabil und positionstreu. Auch bei Druckstößen bleiben sie richtungsstabil.
- Druckstabil. Bei geschlossenem Schlauch bis zu 12 bar, bei geöffnetem Schlauch bis zu 4 bar (größenabhängig).
- Einfach zu verlängern und zu verkürzen.
- Beliebig kombinierbar mit Düsen, Verschraubungen, Abzweigungen, T-Stücken, Reduzierstücken, Verlängerungen usw.

Ausführungen:

Original FlexoLine Gelenkschläuche gibt es in 3 Größen. Bei Bedarf lassen sich alle Größen durch Adapter miteinander verbinden. Der Querschnitt ist in jeder Position konstant und sichert damit einen gleichmäßigen Durchfluss.

Material:

Original FlexoLine Gelenkschläuche bestehen aus hochwertigem Acetal-Copolymer (kein billiges Recycling-Material). Es ist resistent gegen die meisten Chemikalien und Lösungsmittel. Das Material ist nicht elektrisch leitend und somit auch ideal für EDM geeignet.

Unser Service für Sie:

Wir fertigen mit speziellen Montagemaschinen kostengünstig auch kundenspezifische einbaufertige Sets!

Fields of Application:

Original FlexoLine Articulated Hoses are ideal for:

- supplying coolant,
- blowing out workpieces,
- separating sheets of paper,
- sucking off liquids.

Above all in machining centers as well as lathes, milling, drilling, grinding and eroding machines where high bending strength, positional stability, good resistance to chemicals, rapid mounting and many possible combinations are required.

Special Benefits:

- Precise positioning; they will supply liquid or gaseous media to the exact point where these are needed.
- Vibration and positional stability. They will remain directionally stable even in the case of pressure surges.
- Pressure-stabilized up to 12 bars with hose closed, up to 4 bars with hose open (depending on size).
- Easy to lengthen or shorten.
- Easy to combine with nozzles, fittings, Y- or T-fittings, reducing adapters, extensions, etc.

Sizes:

Original FlexoLine Articulated Hoses are available in three sizes. If necessary, all three sizes can be joined with the aid of adapters. Their cross section is constant in any position, ensuring uniform flow.

Material:

Original FlexoLine Articulated Hoses are made of high-quality acetal copolymer (no cheap recycled material). This is resistant to most chemicals and solvents. Being electrically non-conductive, the material is also ideal for EDM.

Our service for you:

Using special assembling machines, we also make reasonably priced custom sets, ready for mounting.



ORIGINAL FlexoLine

Gelenkschläuche / Articulated Hoses

FP 30

1/4"

(6 mm Durchlass/Opening)

Gelenkschläuche / Articulated Hoses

Art. No.	Länge/length mm	Stück/pieces
FP30.10020	300	1
FP30.10072	1.000	1
FP30.10540	7.500	1 Rolle/roll
FP30.10108	15.000	1 Rolle/roll



Komplett-Sets / Complete Sets

Art. No.

FP30.CONFI

bestehend aus:

1 Gelenkschlauch 300 mm
je 1 Runddüse
Ø 1,6 - 3,2 - 4,7 - 5,4 mm
je 1 Anschlussstück 1/4" - 1/8"

consisting of:

1 articulated hose 300 mm
1 each round nozzle diam.
1,6 - 3,2 - 4,7 - 5,4 mm
1 each fitting 1/4" - 1/8"



Runddüsen / Round Nozzles

Art. No.	Ø A mm	Ø D mm	L mm	Stück/pieces (= 1 Set)
FP30.11A04	1,6	15	29	4
FP30.11A50	1,6	15	29	50
FP30.11B04	3,2	15	29	4
FP30.11B50	3,2	15	29	50
FP30.11C04	4,7	15	29	4
FP30.11C50	4,7	15	29	50
FP30.11D04	5,4	15	29	4
FP30.11D50	5,4	15	29	50

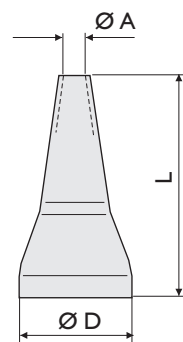

Runddüsen 90° / 90 Degree Round Nozzles

Art. No.	Ø A mm	C mm	L mm	Stück/pieces (= 1 Set)
FP30.11Z04	1,5	20	25	4
FP30.11Z20	1,5	20	25	20

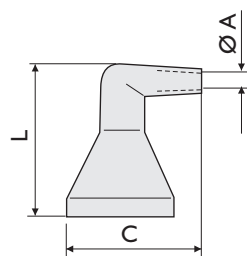

ORIGINAL FlexoLine

Gelenkschläuche / Articulated Hoses

FP 30

1/4"

(6 mm Durchlass/Opening)

Flachdüsen / Flat Nozzles

Art. No.	Ø A x B mm	Ø D mm	L mm	Stück/pieces (= 1 Set)
FP30.12B04	30 x 1,6	15	30	4
FP30.12B20	30 x 1,6	15	30	20

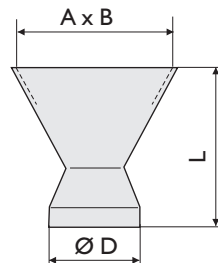

Duschküsen 90° / 90 Degree Spray Bar Nozzles

Art. No.	Ø A mm	C mm	L mm	Stück/pieces (= 1 Set)
FP30.12W02	2,5	19,6	30	2
FP30.12W20	2,5	19,6	30	20

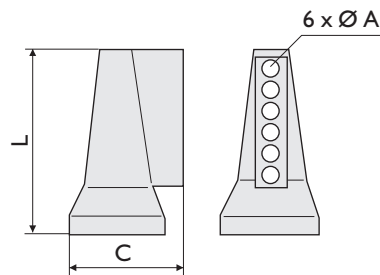

Flachstrahldüsen / Flat Slot Nozzles

Art. No.	Ø A mm	Ø D mm	L mm	Stück/pieces (= 1 Set)
FP30.12X04	1,0	19,6	28	4
FP30.12X20	1,0	19,6	28	20

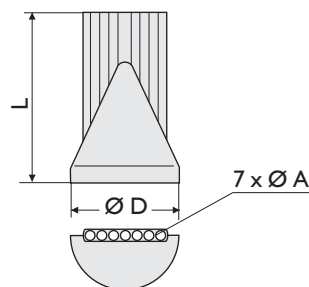

Gelenkduschküsen / Swivel Nozzles

Art. No.	Ø A mm	C mm	CI mm	L mm	Stück/pieces (= 1 Set)
FP30.12Y02	16 x 1,5	48	39	46	2
FP30.12Y20	16 x 1,5	48	39	46	20
FP30.12Z02	20 x 2,0	71	64	46	2
FP30.12Z20	20 x 2,0	71	64	46	20

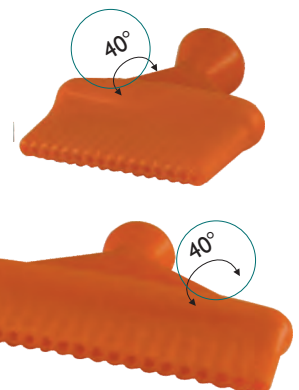
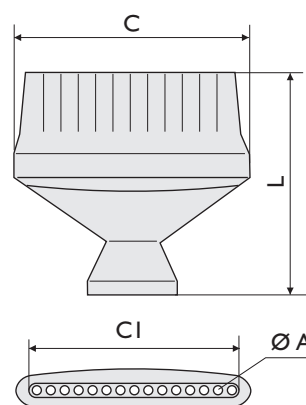

ORIGINAL FlexoLine

Gelenkschläuche / Articulated Hoses

FP 30

1/4"

(6 mm Durchlass/Opening)

Abzweigelemente / Y-Fittings

Art. No.	C mm	L mm	Stück/pieces (= 1 Set)
FP30.13A04	36	38	4
FP30.13A20	36	38	20

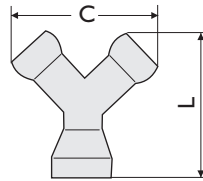

T-Stücke / T-Fittings

Art. No.	C mm	L mm	Stück/pieces (= 1 Set)
FP30.13D04	34	33	4
FP30.13D20	34	33	20

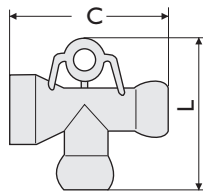

Y-Adapter / Y-Adapters 1/4" → 1/2"

Art. No.	C mm	L mm	Stück/pieces (= 1 Set)
FP40.13B04	36	40	4
FP40.13B20	36	40	20

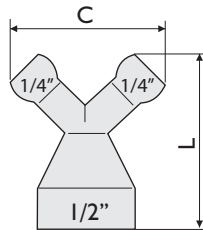

Adapter / Adapters 1/4" → 1/2"

Art. No.	C mm	L mm	Stück/pieces (= 1 Set)
FP40.13C04	25	30	4
FP40.13C20	25	30	20

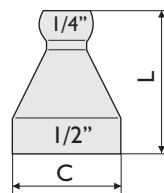

Anschlussstücke "Kugel" / Fittings "Ball"

Art. No.	A	C mm	L mm	LI mm	Stück/pieces (= 1 Set)
FP30.17A04	1/8"	14	27	11	4
FP30.17A20	1/8"	14	27	11	20
FP30.17B04	1/4"	14	27	11	4
FP30.17B20	1/4"	14	27	11	20

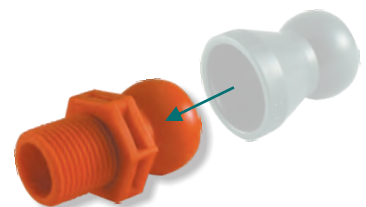
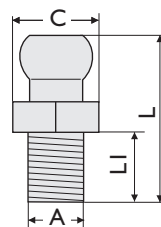

Anschlussstücke "Pfanne" / Fittings "Socket"

Art. No.	A	C mm	L mm	LI mm	Stück/pieces (= 1 Set)
FP30.17C04	1/4"	14	29	11	4
FP30.17D04	1/8"	14	29	11	4

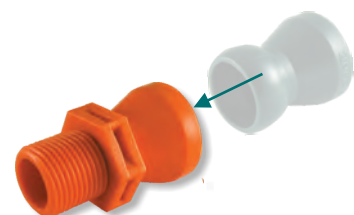
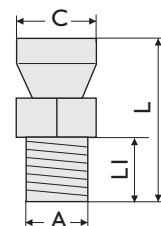

ORIGINAL FlexoLine

Gelenkschläuche / Articulated Hoses

FP 30

1/4"

(6 mm Durchlass/Opening)

Rückschlagventile 1/4" / In-Line Check Valves 1/4"

Verhindern das Nachtropfen der Schlauchleitung/
Avoid dripping of the hose line

Art. No.	C mm	L mm	Stück/pieces (= 1 Set)
FP30.92A02	12	40	2
FP30.92A10	12	40	10

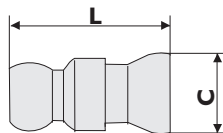

Verlängerungen mit Klemmrings / Extended Elements with clamps

I Set - bestehend aus:

- 4 Verlängerungen
- 4 Klemmstücken
- 4 Schrauben

I Set - consisting of:

- 4 Extended elements
- 4 Clamps
- 4 Screws

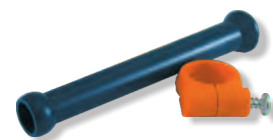
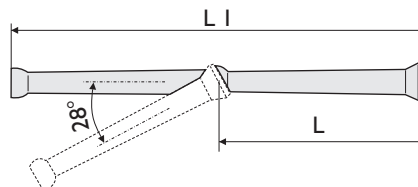

Art. No.	L mm	LI mm	C mm	Stück/pieces (= 1 Set)
FP30.90A04	90	184	26	je 4



Regulierhähne, beidseitig mit je 1 Gelenkstück Control Valves with one segment on both sides

Art. No.	A	C mm	L mm	Stück/pieces (= 1 Set)
FP60.KIT 26 (90.2529.105.06)	1/4"	35	62	4

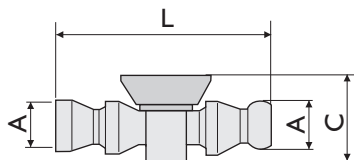

Regulierhähne mit Anschlussstück und Gelenkstück Control Valves with fitting and segment

Art. No.	A	C mm	L mm	Stück/pieces (= 1 Set)
FP60.KIT 32 (90.2529.105.08)	1/4"	35	69	4
FP60.KIT 33 (90.2529.105.09)	1/8"	35	69	4

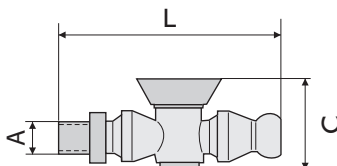

Mini-Kugelhähne aus Metall (siehe Seite 16) / Metal Mini Ball Valves (see page 16)

Montagezangen / Assembly Pliers

Art. No.		Stück/pieces
FP30.PINZA	für/for FP30	1



ORIGINAL FlexoLine

Gelenkschläuche / Articulated Hoses

FP 40

1/2" (12 mm Durchlass/Opening)

Gelenkschläuche / Articulated Hoses

Art. No.	Länge/length mm	 Stück/pieces
FP40.10015	330	1
FP40.10046	1.000	1
FP40.10345	7.500	1 Rolle/roll
FP40.10690	15.000	1 Rolle/roll



Komplett-Sets / Complete Sets

Art. No.

FP40.CONFI

bestehend aus:

1 Gelenkschlauch 330 mm
je 1 Runddüse Ø 6 - 9 - 12 mm
je 1 Anschlussstück 1/2" - 3/8"

consisting of:

1 articulated hose 330 mm
1 each round nozzle
diam. 6 - 9 - 12 mm
1 each fitting 1/2" - 3/8"



Runddüsen / Round Nozzles

Art. No.	Ø A mm	Ø D mm	L mm	 Stück/pieces (= 1 Set)
FP40.11A04	6	25	34	4
FP40.11A50	6	25	34	50
FP40.11B04	9	25	34	4
FP40.11B50	9	25	34	50
FP40.11C04	12	25	34	4
FP40.11C50	12	25	34	50

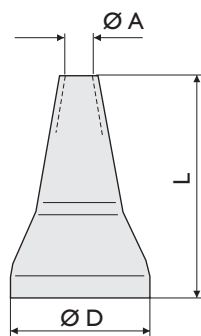

Runddüsen 90° / 90 Degree Nozzels

Art. No.	Ø A mm	C mm	L mm	 Stück/pieces (= 1 Set)
FP40.11Y04	6	31	36,5	4
FP40.11Y20	6	31	36,5	20
FP40.11Z04	9	31	38,0	4
FP40.11Z20	9	31	38,0	20

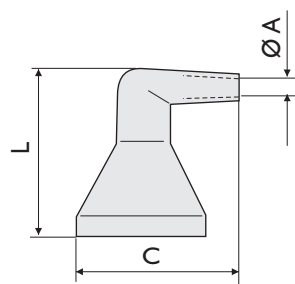

ORIGINAL FlexoLine

Gelenkschläuche / Articulated Hoses

FP 40

1/2" (12 mm Durchlass/Opening)

Flachdüsen / Flat Nozzles

Art. No.	A x B mm	Ø D mm	L mm	Stück/pieces (= 1 Set)
FP40.12A04	40 x 3	25	55	4
FP40.12A20	40 x 3	25	55	20
FP40.12B04	60 x 3	25	55	4
FP40.12B20	60 x 3	25	55	20

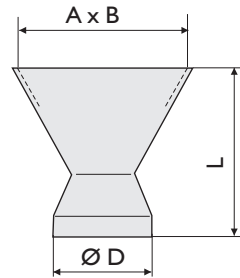

Duschküsen 90° / 90 Degree Spray Bar Nozzles

Art. No.	Ø A mm	C mm	L mm	Stück/pieces (=1 Set)
FP40.12W02	4,3	31	58,3	2
FP40.12W20	4,3	31	58,3	20

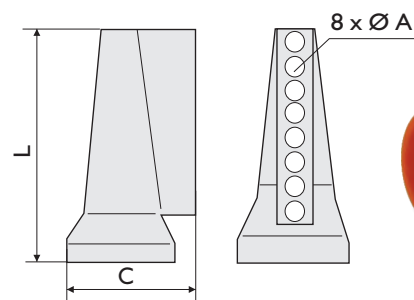

Flachstrahldüsen / Flat Slot Nozzles

Art. No.	Ø A mm	Ø D mm	L mm	Stück/pieces (= 1 Set)
FP40.12X04	7x 2,0	25	37,6	4
FP40.12X20	7x 2,0	25	37,6	20
FP40.12Y04	5x 3,2	25	37,6	4
FP40.12Y20	5x 3,2	25	37,6	20

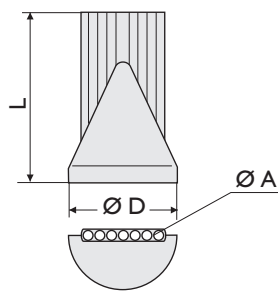

Gelenkduschküsen / Swivel Nozzles

Art. No.	Ø A mm	C mm	CI mm	L mm	Stück/pieces (= 1 Set)
FP40.12Z02	2,0	71	63,5	59	2
FP40.12Z20	2,0	71	63,5	59	20

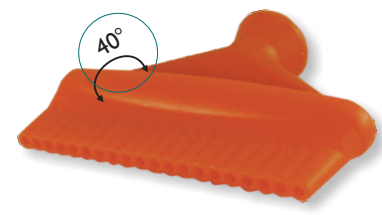
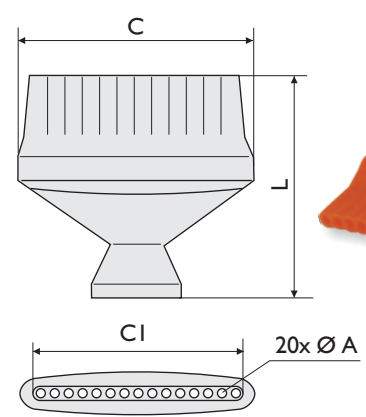

ORIGINAL FlexoLine

Gelenkschläuche / Articulated Hoses

FP 40

1/2" (12 mm Durchlass/Opening)

Abzweigelemente / Y-Fittings

Art. No.	C mm	L mm	Stück/pieces (=1 Set)
FP40.13A04	56	50	4
FP40.13A20	56	50	20

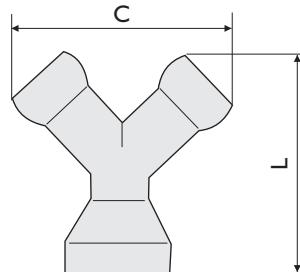

Y-Adapter / Y-Adapters 1/2" → 1/4"

Art. No.	C mm	L mm	Stück/pieces (=1 Set)
FP40.13B04	36	40	4
FP40.13B20	36	40	20

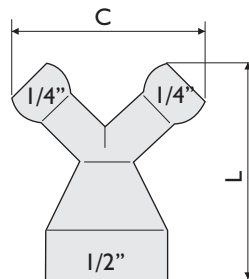

Y-Adapter / Y-Adapters 1/2" → 3/4"

Art. No.	C mm	L mm	Stück/pieces (= 1 Set)
FP50.13B04	31	62	4
FP50.13B20	31	62	20

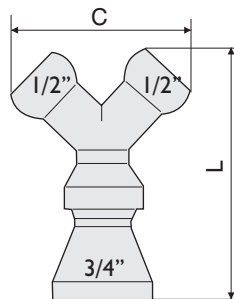

Adapter / Adapters 1/2" → 1/4"

Art. No.	C mm	L mm	Stück/pieces (=1 Set)
FP40.13C04	25	30	4
FP40.13C20	25	30	20

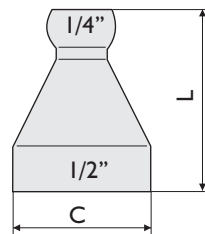

Adapter / Adapters 1/2" → 3/4"

Art. No.	Ø C mm	L mm	Stück/pieces (= 1 Set)
FP50.13C04	31	36	4
FP50.13C20	31	36	20

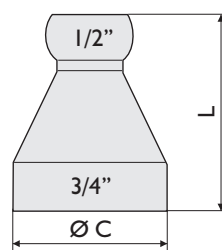

ORIGINAL FlexoLine

Gelenkschläuche / Articulated Hoses

FP 40

1/2" (12 mm Durchlass/Opening)

T-Stücke / T-Fittings

Art. No.	C mm	L mm	Stück/pieces (= 1 Set)
FP40.13D04	48	44	4
FP40.13D20	48	44	20

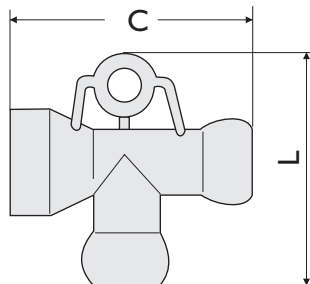

Anschlussstücke "Kugel" / Fittings "Ball"

Art. No.	A	C mm	L mm	LI mm	Stück/pieces (= 1 Set)
FP40.17A04	3/8"	22	38	15	4
FP40.17A20	3/8"	22	38	15	20
FP40.17B04	1/2"	22	38	15	4
FP40.17B20	1/2"	22	38	15	20

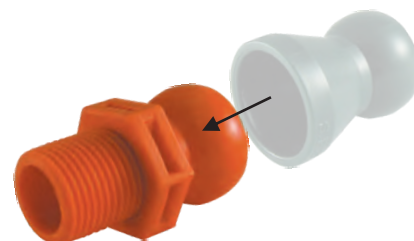
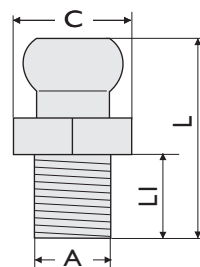

Anschlussstücke "Pfanne" / Fittings "Socket"

Art. No.	A	C mm	L mm	LI mm	Stück/pieces (= 1 Set)
FP40.17C04	1/2"	22	38	15	4
FP40.17D04	3/8"	22	38	15	4

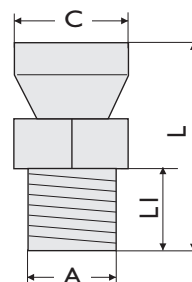

Rückschlagventile 1/2" / In-Line Check Valves 1/2"

Verhindern das Nachtropfen der Schlauchleitung/
Avoid dripping of the hose line

Art. No.	C mm	L mm	Stück/pieces (= 1 Set)
FP40.92A02	20	45	2
FP40.92A10	20	45	10

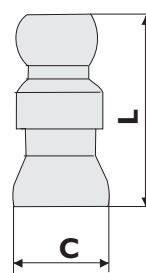

ORIGINAL FlexoLine

Gelenkschläuche / Articulated Hoses

FP 40

1/2"

(12 mm Durchlass/Opening)

Verlängerungen mit Klemmringen / Extended Elements with clamps

I Set - bestehend aus:
 4 Verlängerungen
 4 Klemmstücken
 4 Schrauben

I Set - consisting of:
 4 Extended elements
 4 Clamps
 4 Screws

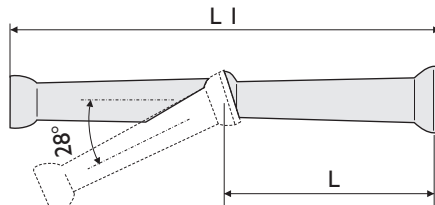

Art. No.	L mm	L I mm	C mm	Stück/pieces (= 1 Set)
FP40.90A04	90	187	35,5	je 4

Klemmringe / Elements Clamps

mit Torx-Schrauben/ with Torx Screws

Um eine Positionsveränderung des Gelenkschlauches bei höherem Druck zu verhindern, können die Elemente mit Klemmringen verschraubt werden.



These clamps tighten onto any element to prevent an alteration of the hose setting in case of higher pressure.

Art. No.	Stück/pieces (= 1 Set)
FP40.90B04	4
FP40.90B20	20

Regulierhähne, beidseitig mit je 1 Gelenkstück Control Valves with one segment on both sides

Art. No.	A	C mm	L mm	Stück/pieces (= 1 Set)
FP60.KIT 27 (90.2529.105.07)	1/2"	45	98	4

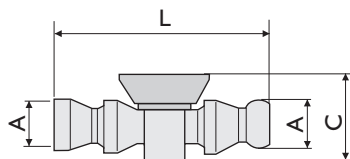

Regulierhähne mit Anschlussstück und Gelenkstück Control Valves with fitting and segment

Art. No.	A	C mm	L mm	Stück/pieces (= 1 Set)
FP60.KIT 34 (90.2529.105.10)	3/8"	45	106	4
FP60.KIT 35 (90.2529.105.11)	1/2"	45	106	4

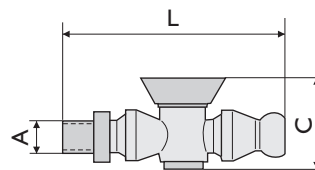

Mini-Kugelhähne aus Metall (siehe Seite 16) / **Metal Mini Ball Valves** (see page 16)

Montagezange / Assembly Plier

Art. No.	Stück/pieces
FP40.PINZA für/for FP40	1



ORIGINAL FlexoLine

Gelenkschläuche / Articulated Hoses

FP 50

3/4"

(20 mm Durchlass/Opening)

Gelenkschläuche / Articulated Hoses

Art. No.	Länge/length mm	Stück/pieces 
FP50.10015	360	1
FP50.10042	1.000	1
FP50.10158	7.500	1 Rolle/roll



Komplett-Sets / Complete Sets

Art. No.

FP50.CONFI

bestehend aus:

1 Gelenkschlauch 360 mm
je 1 Runddüse Ø 16 und 20 mm
1 Anschlussstück 3/4"

consisting of:

1 articulated hose 360 mm
1 each round nozzle
diam. 16 and 20 mm
1 fitting 3/4"



Runddüsen / Round Nozzles

Art. No.	Ø A mm	Ø D mm	L mm	Stück/pieces (= 1 Set) 
FP50.11A04	16	31	33	4
FP50.11A50	16	31	33	50
FP50.11B04	20	31	33	4
FP50.11B50	20	31	33	50

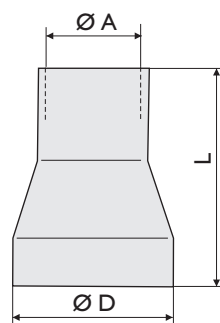

Flachdüsen / Flat Nozzles

Art. No.	A x B mm	Ø D mm	L mm	Stück/pieces (= 1 Set) 
FP50.12A04	75 x 5	31	80	4
FP50.12A20	75 x 5	31	80	20

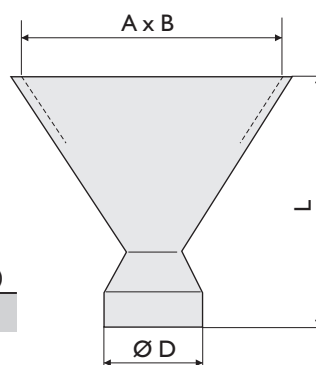

ORIGINAL FlexoLine

Gelenkschläuche / Articulated Hoses

FP 50

3/4"

(20 mm Durchlass/Opening)

Y-Adapter / Y-Adapters

Art. No.	C mm	L mm	Stück/pieces (= 1 Set)
FP50.13B04	31	62	4
FP50.13B20	31	62	20

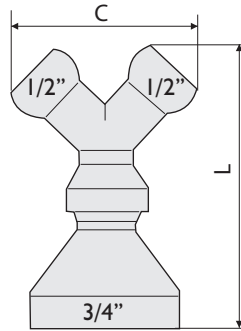

Adapter / Adapters 3/4" → 1/2"

Art. No.	Ø C mm	L mm	Stück/pieces (= 1 Set)
FP50.13C04	31	36	4
FP50.13C20	31	36	20

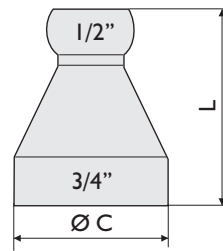

Anschlussstücke / Fittings

Art. No.	A	C mm	L mm	Stück/pieces (= 1 Set)
FP50.17A04	3/4"	28	39	4
FP50.17A20	3/4"	28	39	20

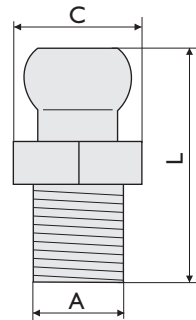

Regulierhähne aus Metall / Metal Control Valves

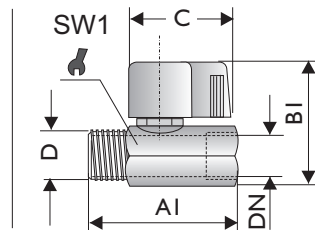
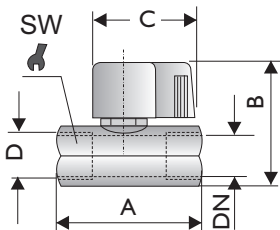

Typ(e) AH ... KG



Typ(e) AH ... KGIA



Typ AH ... KG mit 2 x Innengewinde with two female threads	Typ AH ... KGIA mit Innen-/Außengewinde with female/male threads	Gewinde nach Thread as per ISO 228 D	DN	A	A1	B	B1	C	SW	SW1	Stück pieces
AH 34 KG	AH 34 KGIA	G 3/4"	20	54	51	47	47	30	30	30	1

ORIGINAL FlexoLine

Gelenkschläuche / Articulated Hoses

Ringspülsystem / Annular Flushing System

Ringspülsystem mit seitlichen Düsen / Annular flushing system with lateral nozzles

Für bestimmte Fräsarbeiten ist dieses System ideal. Die aus Segmenten bestehenden Spülschläuche sind an beiden Enden mit Verschlusskappen versehen. Bei gerader Positionierung der Spüldüsen ergibt sich ein Kühlmittelvorhang zur optimalen Späneentfernung.

This system is ideal for certain kinds of milling work. The segmented flushing hoses have caps at either end. With the flushing nozzles in a straight position, a coolant curtain will be created that ensures optimal removal of chips.

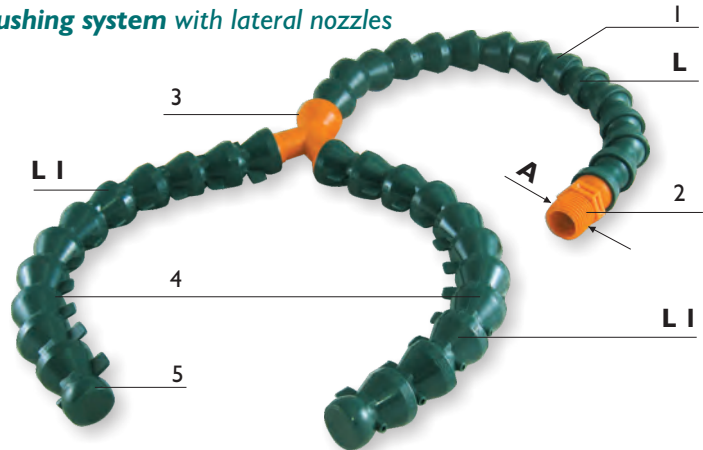

Art. No.	A	L mm	L I mm	Set
FP30.CONF2	1/4"	280	150	1
FP40.CONF2	1/2"	325	240	1

bestehend aus:

1. 1 Gelenkschlauch
2. 1 Anschlussstück
3. 1 Abzweigelement
4. 20 Seitenstrahldüsen, offen
5. 2 Seitenstrahldüsen, geschlossen

consisting of:

1. 1 articulated hose
2. 1 Fitting
3. 1 Y-Fitting
4. 20 Side flow nozzles, open
5. 2 Side flow nozzles, locked

Seitenstrahldüsen/ Side Flow Nozzles

offen/ open

Art. No.	Set
FP30.14A08	8
FP30.14A20	20
FP40.14A04	4
FP40.14A20	20

geschlossen/ closed

Art. No.	Set
FP30.15A08	8
FP30.15A20	20
FP40.15A04	4
FP30.15A20	20



Seitenstrahldüse, offen
Side flow nozzle, open



Seitenstrahldüse, geschlossen
Side flow nozzle, closed

ORIGINAL FlexoLine

Gelenkschläuche / Articulated Hoses

Magnetversionen / Magnetic Versions

Magnetset mit 1 Schlauch / Magnetic Set with 1 hose

Starke Magnetbasis (~180 N) mit 1 Gelenkschlauch, 1 Regulierhahn und Schlauchanschluss.

Strong magnetic base (~180 N) with one articulated hose, one control valve and one hose fitting.

Art. No.		FP61.KIT05 FP30 (1/4")	FP61.KIT07 FP40 (1/2")	
1	1 Dauermagnet Haltekraft	Ø 60 x 50 mm ~ 180 N	Ø 60 x 50 mm ~ 180 N	1 Magnetic base Holding power
2	1 Flachdüse	30 x 1,6 mm	40 x 3 mm	1 Flat nozzle
3	1 Anschlussstück	1/4"	3/8"	1 Fitting
4	1 Gelenkschlauch	300 mm	300 mm	1 Artic. hose
5	1 Regulierhahn	Stahl/steel	Stahl/steel	1 Control valve
6	1 Schlauchanschluss	1/4"	3/8"	1 Hose fitting

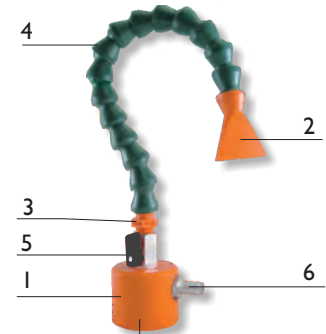

Ersatzmagnet
siehe Seite 16

Spare magnet
see page 16

Magnetset mit 2 Schläuchen / Magnetic Set with 2 hoses

Starke Magnetbasis (~180 N) mit 2 Gelenkschläuchen, 1 Regulierhahn und mit Schlauchanschluss.

Strong magnetic base (~180 N) with two articulated hoses, one control valve and one hose fitting.

Art. No.		FP61.KIT06 FP30 (1/4")	FP61.KIT08 FP40 (1/2")	
1	1 Dauermagnet Haltekraft	Ø 60 x 50 mm ~ 180 N	Ø 60 x 50 mm ~ 180 N	1 Magnetic base Holding power
2	2 Flachdüsen	30 x 1,6 mm	40 x 3 mm	2 Flat nozzle
3	1 Anschlussstück	1/4"	3/8"	1 Fitting
4	2 Gelenkschläuche	300 mm	300 mm	2 Artic. hoses
5	1 Regulierhahn	Stahl/steel	Stahl/steel	1 Control valve
6	1 Schlauchanschluss	1/4"	3/8"	1 Hose fitting
7	1 Y-Abzweigstück	1 x	1 x	1 Y-Fitting

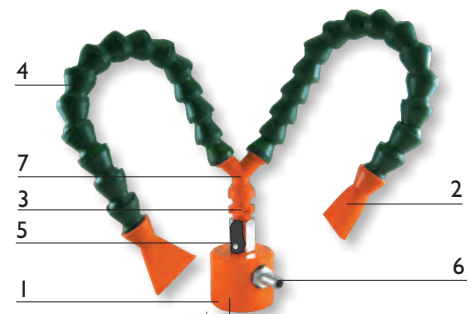

Ersatzmagnet
siehe Seite 16

Spare magnet
see page 16

Magnetset "Medusa" / Magnetic Set "Medusa"

Starke Magnetbasis (~300 N) mit 4 absperrbaren Gelenkschläuchen und mit Schlauchanschluss.

Strong magnetic base (~300 N) with four articulated hoses with control valves and hose fitting.

Art. No.		FP80.CONFI FP30 (1/4")	
1	1 Dauermagnet Haltekraft	Ø 80 x 50 mm ~ 300 N	1 Magnetic base Holding power
2	4 Regulierhähne	1/4"	4 Control valves
3	4 Flachdüsen	30 x 1,6 mm	4 Flat nozzles
4	je 4 Runddüsen	1,6 - 3,2 - 4,7 - 5,4 mm	each 4 round nozzles
5	4 Gelenkschläuche	je /each 300 mm	4 Artic. hoses
6	1 Anschlussstück	1/4"	1 Fitting
7	1 Schlauchanschluss	1/4"	1 Hose fitting

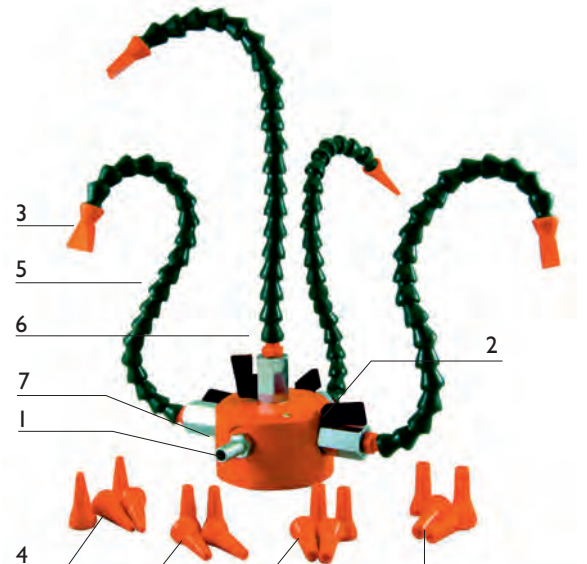

Ersatzteile auf Anfrage / Spare parts on request

ORIGINAL FlexoLine

Gelenkschläuche / Articulated Hoses

Zubehör / Accessories

Magnetfuß / Magnetic Base

Ersatzmagnetfuß für FP61.KIT05 - 08 (siehe Seite 15). Auch für PowerFlex Metallschläuche geeignet. Haltekraft ~180 N

Spare magnetic base for FP61.KIT05 - 08 (see page 15). Also for PowerFlex Metal Hoses. Holding power ~180 N

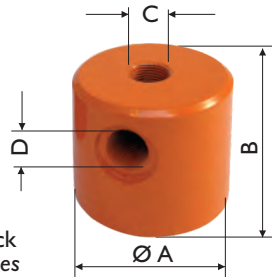

Art. No.	Ø A mm	B mm	C	D mm	Stück pieces
Base 14	60	50	G 1/4"	G 1/4"	1
Base 38	60	50	G 3/8"	G 3/8"	1

Schraub-Schlauchtüllen Screw-in hose fitting

Messing vernickelt nickel-plated brass
O-Ring (NBR)

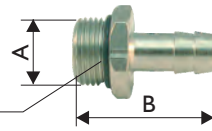

Art. No.	A mm	B mm	für Schlauch LW for Hose ID mm	Stück pieces
GT 14	G 1/4"	33	9	1
GT 38	G 3/8"	34	12	1

Mini-Kugelhahn mit Knebelgriff, PN 15

Arbeits-Temperaturbereich: 0 °C bis +90 °C
Körper und Kugel: Messing verchromt
Dichtungen: Teflon/NBR
Griff: Kunststoff
Gewinde: ISO 228

Mini Ball Valve with lever handle, PN 15

Working temperature: 0 °C to +90 °C
Body and ball: chrome-plated brass
Sealings: PTFE/NBR
Handle: Nylon
Threads: ISO 228

Typ AH ... KG mit 2 x Innengewinde with two female threads	Typ AH ... KGIA mit Innen-/Außengewinde with female/male threads	Gewinde nach Thread as per ISO 228 D	DN	A	A1	B	B1	C	SW	SW1
AH 18 KG	AH 18 KGIA	G 1/8"	6	40	38	39	37	30	21	20
AH 14 KG	AH 14 KGIA	G 1/4"	8	40	38	39	37	30	21	20
AH 38 KG	AH 38 KGIA	G 3/8"	10	40	38	40	37	30	21	20
AH 12 KG	AH 12 KGIA	G 1/2"	15	46	42	45	41,5	30	25	24
AH 34 KG	AH 34 KGIA	G 3/4"	20	54	47	51	47	30	30	30

Hochdruckdüsen/ High Pressure Turret Nozzles

für Kühlmittel und Luft bis 70 bar/ expand the working pressure range of coolant and air up to 70 bars

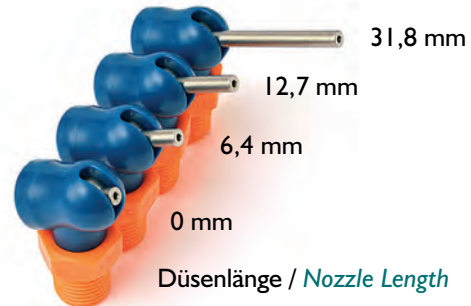
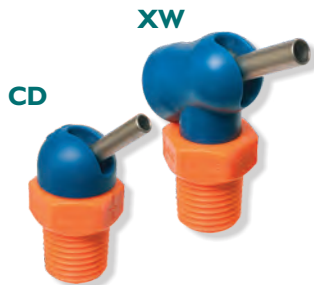

Hohe Zerspanleistung erfordert hohe Ansprüche an die Kühlmittelversorgung. Hierbei können wir helfen! Mit Hochdruckdüsen bis 70 bar Arbeitsdruck.

Lieferbar mit

- 2 Schwenkbereichen:
CD = Compact-Düse: bis 72°
XW = Weitwinkel-Düsen: bis 110°
- In 2 Gewindegrößen: 1/8" und 1/4"
- 4 Düsen-Ø (Edelstahl): 1,6 - 2,2 - 3 - 4,1 mm
- 4 Düsenlängen: 0 - 6,4 - 12,7 - 31,8 mm

Eingeschraubt können die Düsen um 360° gedreht werden. Der Winkel ist mit einem Innensechskantschlüssel justierbar. Einmal eingestellt, bleibt die Düse konstant in ihrer Position.

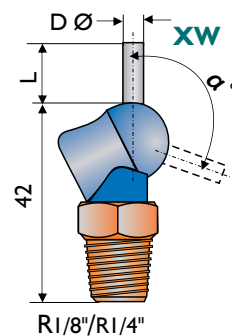
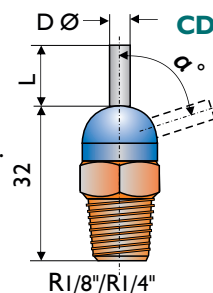

High pressure turret nozzles help to increase the speed and precision of both normal and high pressure CNC machining with less risk of downtime.

Available in

- 2 swivel ranges:
CD = Compact nozzle: up to 72°
XW = Wide nozzle: up to 110°
- 2 thread sizes: 1/8 inch and 1/4 inch
- 4 nozzle dia. (stainless steel):
1,6 - 2,2 - 3 - 4,1 mm
- 4 nozzle lengths: 0 - 6,4 - 12,7 - 31,8 mm

Once screwed in, the nozzles can be rotated by 360°. The working angle can be adjusted with an Allen key. Once set, the nozzle remains constant in its position.

CD Compact Düsen 1/8"

CD Compact Nozzles 1/8 inch

D Ø mm	Art. No. / Düsenlänge L in mm Art. No. / Nozzle length in mm				α
	0	6,4	12,7	31,8	
1,6	FP92.010	FP92.011	FP92.012	FP92.013	72°
2,2	FP92.014	FP92.015	FP92.016	FP92.017	72°
3,0	FP92.018	FP92.019	FP92.020	FP92.021	72°
4,1	FP92.022	FP92.023	FP92.024	FP92.025	70°

XW Weitwinkel-Düsen 1/8"

XW Wide Angle Nozzles 1/8 inch

D Ø mm	Art. No. / Düsenlänge L in mm Art. No. / Nozzle length in mm				α
	0	6,4	12,7	31,8	
1,6	FP92.040	FP92.041	FP92.042	FP92.043	110°
2,2	FP92.044	FP92.045	FP92.046	FP92.047	110°
3,0	FP92.048	FP92.049	FP92.050	FP92.051	110°
4,1	FP92.052	FP92.053	FP92.054	FP92.055	102°

CD Compact Düsen 1/4"

CD Compact Nozzles 1/4 inch

D Ø mm	Art. No. / Düsenlänge L in mm Art. No. / Nozzle length in mm				α
	0	6,4	12,7	31,8	
1,6	FP92.060	FP92.061	FP92.062	FP92.063	72°
2,2	FP92.064	FP92.065	FP92.066	FP92.067	72°
3,0	FP92.068	FP92.069	FP92.070	FP92.071	72°
4,1	FP92.072	FP92.073	FP92.074	FP92.075	70°

XW Weitwinkel-Düsen 1/4"

XW Wide Angle Nozzles 1/4 inch

D Ø mm	Art. No. / Düsenlänge L in mm Art. No. / Nozzle length in mm				α
	0	6,4	12,7	31,8	
1,6	FP92.080	FP92.081	FP92.082	FP92.083	110°
2,2	FP92.084	FP92.085	FP92.086	FP92.087	110°
3,0	FP92.088	FP92.089	FP92.090	FP92.091	110°
4,1	FP92.092	FP92.093	FP92.094	FP92.095	102°



STEINBOCK GmbH

Industrie-Ausrüstungen • Industrial Components



STEINBOCK GmbH

Freisinger Str. 30
85737 Ismaning / München
www.steinbock-industrie.de

Phone +49 (0) 89 / 999 399-01
Fax +49 (0) 89 / 999 399-85
info@steinbock-industrie.de